

THE 9TH KEY TO THE

RIDDLE OF TIME

BY STEVEN L. GIBBS

DISCLAIMER

WE STRIVE TO PRODUCE A QUALITY PRODUCT,
BUT ITS USE IS OUT OF OUR CONTROL.
THEREFORE WE LIMIT OUR LIABILITY TO THE
PRODUCTS ORIGINAL PURCHASE PRICE.
THE AUTHOR NOR THE PUBLISHER ASSUME ANY
RESPONSIBILITY FOR THE USE OR MISUSE
OF THE INFORMATION CONTAINED HEREIN.

DEDICATION

I WOULD LIKE TO DEDICATE THIS REPORT TO
PATRICIA RESS, E. QUAY FITCH, AND ALLEN CLARK.

THANKYOU FOR GIVING ME THE INSPIRATION
FOR WRITING THIS REPORT.

MAY THE LORD BLESS AND KEEP YOU AND BE
GRACIOUS UNTO YOU, MAY THE LORD LIFT HIS
COUNTENANCE UPON YOU AND GIVE THEE PEACE.

THANKYOU FOR BEING MY FRIENDS.

INTRODUCTION

THERE ARE MANY DIFFERENT TYPES OF RADIONIC MACHINES WHICH ARE BEING SOLD ON THE MARKET TODAY, WHICH BELIEVE IT OR NOT, CAN ACTUALLY BE USED FOR PHYSICAL TIME TRAVEL. IN OTHER WORDS, IF ONE OF THESE DEVICES IS RADIONICALLY TUNED FOR THE YEAR, MONTH, AND DAY THAT YOU WISH TO TRAVEL TO WHILE STANDING OVER A (NATURAL) GRID POINT, YOU CAN ACTUALLY TRAVEL PHYSICALLY THROUGH TIME PROVIDED OF COURSE THAT YOU ARE STANDING OVER THE RIGHT TYPE OF GRID POINT AND THE GRID POINT IS ACTIVATED. THE BEST TYPE OF GRID POINTS TO USE ARE THE ONES WHERE UFO'S ARE SIGHTED. THE REASON FOR THIS BECOMES APPARENT, IF YOU CONSIDER THE POSSIBILITY THAT SOME OF THESE UFO'S ARE COMING FROM EARTH'S PAST AND FUTURE.

NOW FOR A WORD OF CAUTION!!! IF YOU DECIDE TO TAKE THIS ROUTE MAKE DAM CERTAIN THAT THE RADIONICS MACHINE THAT YOU ARE USING CONTAINS NO TOXIC OR NEGATIVE VIBRATIONS. FOR IF IT DOES, AND YOU DECIDE TO USE IT FOR PHYSICAL TIME TRAVEL, IT COULD EASILY TRANSPORT YOUR PHYSICAL BODY INTO A NEGATIVE REALM IN SOME OTHER DIMENSION. NOW THE BEST WAY TO CLEAR ONE OF THESE RADIONICS MACHINES, IS TO FIRST ASK THE LORD TO BLESS IT BY SIMPLY PRAYING OVER IT. NEXT, TAKE SOME SALT WATER AND BLESS THE MACHINE WHILE SAYING SOMETHING LIKE THIS:- I DO HEREBY BLESS THIS MACHINE IN THE NAME OF THE (FATHER), (SON), AND (HOLY GHOST). WHILE SAYING THESE WORDS, SPRINKLE THE MACHINE OR CIRCUIT 3 TIMES, ONCE FOR THE (FATHER), ONCE FOR THE (SON), AND THEN FOR THE (HOLY GHOST). IF YOU HAVE DONE EVERYTHING CORRECTLY, NOTHING NEGATIVE WILL EFFECT YOUR MACHINE.

THE (DEMAT CANNON) OR THE (TACYON WAVE ENHANCER), IS BY NO MEANS A TOY. IN OTHER WORDS, THIS DEVICE PRODUCES SUCH AN INCREDIBLE AMOUNT OF TACYON PARTICLES, THAT IF IT WERE TO BE RADIONICALLY TUNED WHILE STANDING OVER A LARGE OR MAJOR GRID POINT, IT CAN ACTUALLY BE USED TO OPEN UP DOORWAYS LEADING TO OTHER DIMENSIONAL REALMS AS WELL AS TO THE PAST OR FUTURE OF THIS EARTH. ALL THESE THINGS WHICH I HAVE SPOKEN OF, CAN ACTUALLY BE ACCOMPLISHED WITH THIS DEVICE PROVIDED OF COURSE THAT YOUR INTENTIONS ARE PURE AND IN ACCORDANCE WITH THE CREATORS WILL. IF NOT NOTHING WILL HAPPEN.

CONSTRUCTION

THIS DEVICE IS EXTREMELY SIMPLE TO BUILD. ALL THAT IS NEEDED ARE THE FOLLOWING ITEMS:-

ONE 3 FOOT X 3 INCH PVC TUBE

ONE 3 FOOT X 2-14/16 INCH COPPER TUBE

ONE 3 INCH PVC CAP

WHEN CONSTRUCTING THIS DEVICE, THE COPPER TUBE WHICH FITS INSIDE THE PVC TUBE, SHOULD BE LOOSE ENOUGH SO THAT THE COPPER TUBE CAN SLIDE FREELY IN AND OUT OF THE (PVC) TUBE. IF THERE IS A PROBLEM IN GETTING THE CORRECT SIZE FOR THIS PURPOSE, OR SHOULD THE DIAMETER OF THE COPPER TUBE BE TOO SMALL, ONE CAN ALWAYS WRAP THE COPPER TUBE WITH PLASTIC WRAP, THAT IS UNTIL IT FITS SECURELY IN PLACE. AFTER YOU HAVE DONE THIS, ALL YOU HAVE LEFT TO DO IS TO FIT THE (3) INCH PVC CAP OVER ONE END OF THE PVC TUBE, AND YOU'RE ALL SET. A DETAILED DRAWING OF THIS DEVICE IS GIVEN ON PAGE (2).

DETAILED DRAWING OF DEMAT CANNON

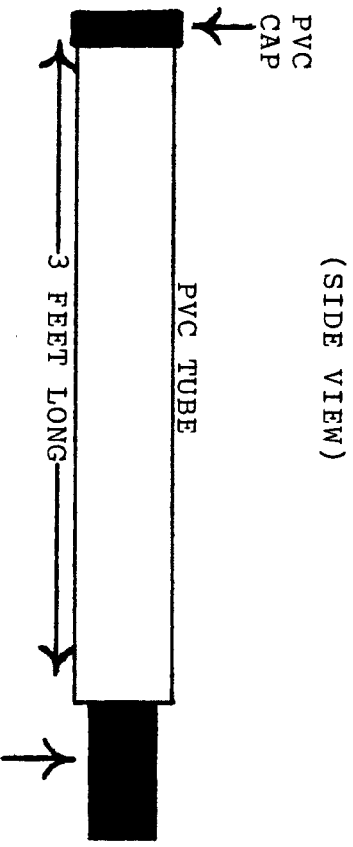
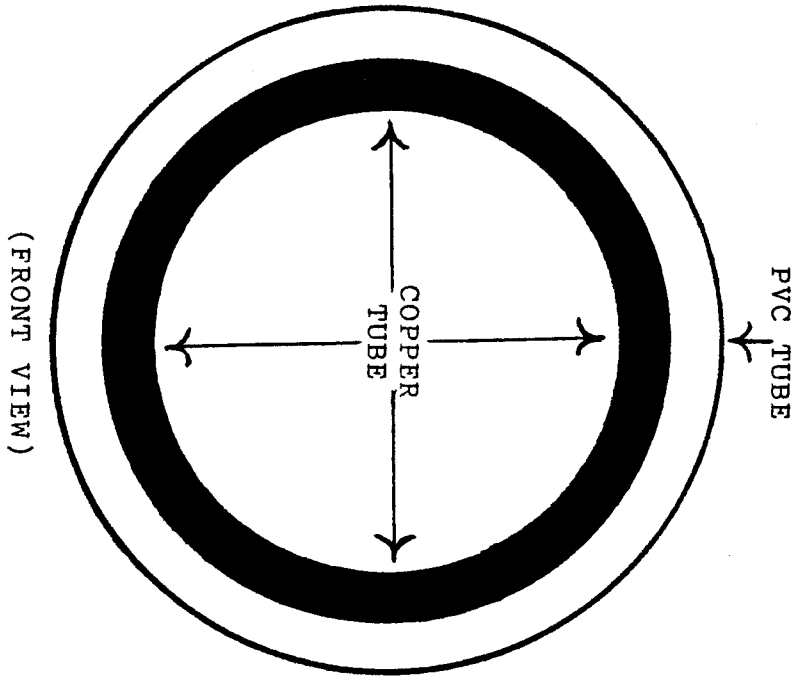

*NOTE: THE PVC TUBE SHOULD BE 3 FEET X 3 INCHS IN DIAMETER AND THE COPPER FOCUSING TUBE SHOULD BE 3 FEET X 2-14/16 INCHES IN DIAMETER.

OPERATION

FIRST OF ALL, IN ORDER TO BE ON THE SAFE SIDE, I STRONGLY SUGGEST THAT A PERSON SHOULD SAY A PRAYER OVER THE DEMAT CANNON BEFORE HE ATTEMPTS TO USE IT FOR OPENING UP DOORWAYS. THE REASON I SAY THIS IS BECAUSE, IF YOU DON'T PUT JESUS CHRIST FIRST IN YOUR LIFE, THEN HOW DO YOU EXPECT TO GET ANY RESULTS, AND ESPECIALLY SO IF YOUR INTENTIONS ARE NOT PURE. SO THEREFORE IN MY OPINION, IT IS BETTER TO BE SAFE THAN SORRY. BUT ANYHOW, AFTER YOU HAVE TAKEN THE NECESSARY PRECAUTIONS, WHILE YOU ARE STROKING A RUBBING PLATE (OR ANY HARD SURFACE FOR THAT MATTER) PUSH OR PULL THE (COPPER TUBE) IN OR OUT OF THE PVC TUBE WHILE CONCENTRATING ON THE FOLLOWING QUESTION, FOR EXAMPLE:- WHAT IS THE TUBULAR CORE SETTING WHICH WILL OPEN UP A DOORWAY TO JUNE 15TH, 1895? NEXT, WHILE CONCENTRATING ON THE PREVIOUS QUESTION AND ALSO WHILE YOU ARE STROKING THE RUBBING PLATE, TRY TO MENTALLY VISUALIZE A DOORWAY OPENING UP TO THAT PARTICULAR TIME FRAME OR UNIVERSE. NOW AS SOON AS YOUR FINGERS STICK ON THE RUBBING PLATE, THIS MEANS THAT YOU HAVE HIT THE CORRECT SETTING, WHICH WOULD INDICATE AT THIS POINT THERE IS NO NEED TO ADJUST THE TUBE ANY FURTHER. NOW ALL YOU HAVE LEFT TO DO IS TO AIM THE (DEMAT CANNON) AT ANY SOLID WALL IN YOUR HOUSE. IF YOU HAVE DONE EVERYTHING CORRECTLY, A DOORWAY TO A PAST OR FUTURE UNIVERSE SHOULD OPEN UP IN LESS THAN 30 MINUTES, DEPENDING OF COURSE ON WHERE YOU ARE LOCATED. FOR THIS PURPOSE, IT MAY PROVE TO THE PERSON'S ADVANTAGE, IF THIS DEVICE WERE TO BE ACTIVATED NEAR OR CLOSE

TO A LARGE OR MAJOR GRID POINT, OR BETTER YET NEAR A GRID POINT WHERE UFO'S ARE SIGHTED. SO BASICALLY, WHATEVER YOU DECIDE TO DO, BE CAREFUL, FOR GRID POINTS TRANSMIT AND COLLECT MORE (TACYON) PARTICLES THAN MOST PEOPLE REALIZE. ALSO, TRY TO STAY AWAY FROM NEGATIVE GRID POINTS, OR GRID POINTS WHERE YOU SENSE SOMETHING EVIL OR BAD. BECAUSE IF THIS DEVICE IS ACTIVATED NEAR OR CLOSE TO ONE OF THESE NEGATIVE GRID POINTS, OR IN A PLACE WHERE ANGELS DO NOT TREAD, IT MAY BE WISE NOT TO DESCRIBE WHAT THE AFTER EFFECTS MIGHT BE!

IT SHOULD ALSO BE ADDED, THAT IF YOU WANT, AFTER EACH AND EVERY TIME YOU TUNE THE (DEMAT CANNON) WITH AN INK PEN PLACE A MARK ON THE COPPER TUBE NEXT TO THE OPEN END OF THE PVC TUBE, SO THAT IF YOU NEED TO USE THIS SETTING AGAIN, YOU CAN EASILY ADJUST THE COPPER TUBE WITHOUT GOING THROUGH THE HASSLE OF RADIONICALLY TUNING THE DEVICE EACH AND EVERY TIME. A DETAILED DRAWING OF HOW THIS TUBE SHOULD BE MARKED, IS GIVEN ON PAGE (5). AND THAT'S ALL THERE IS TO IT!

WARNING

EVEN THOUGH THE (DEMAT CANNON) TRANSMITS A POSITIVE PI RAY, I MUST CAUTION MY READERS ABOUT STANDING IN FRONT OF THE DEMAT CANNON FOR ANY LONG PERIOD OF TIME. THE REASON I MENTION THIS IS BECAUSE, THESE TACYON PARTICLES COULD EASILY OVERLOAD YOUR (CHAKRA) CENTERS AND FOR SOME PEOPLE IT COULD CREATE SOME SERIOUS HEALTH PROBLEMS. REMEMBER! THIS DEVICE IS STILL IN THE (EXPERIMENTAL) STAGES, AND SHOULD YOU DECIDE TO TAKE THIS ROUTE, I HOPE THAT YOU WILL USE SOME COMMON SENSE!

FULL SCALE DRAWING OF DEMAT CANNON

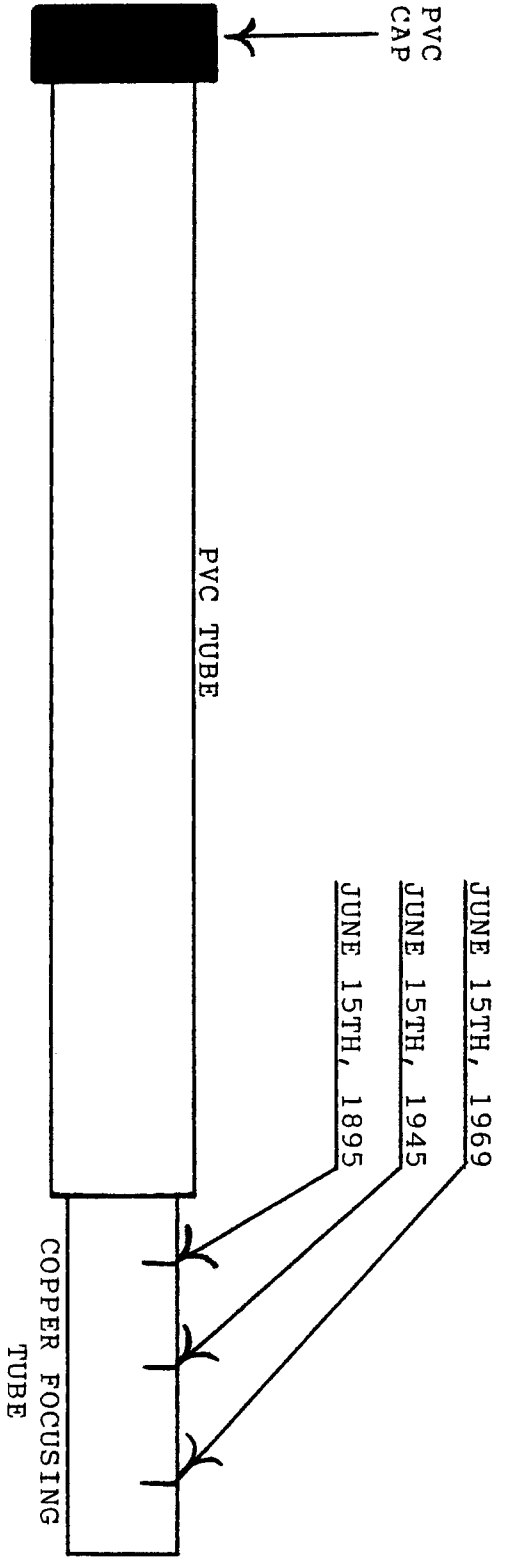

*NOTE: THE COPPER FOCUSING TUBE HAS BEEN CLEARLY MARKED
FOR EACH PARTICULAR TIME FRAME.

BELIEVE IT OR NOT, BUT WHILE I WAS STAYING IN CALGARY CANADA, I WAS CONTACTED BY WHAT I BELIEVE TO BE WAS AN ANGEL. HE TOLD ME THAT BEFORE HIS DEATH HE USE TO BE A TIME TRAVEL PHYSICIST WHO WAS WORKING ON A FLUID CHAMBER EXPERIMENT BACK IN THE MID 1960'S. HE CLAIMED THAT HIS DEATH WAS BROUGHT ABOUT, WHEN ONE OF THE (FLUID CHAMBERS) HE WAS WORKING ON EXPLODED. WELL ANYHOW, ACCORDING TO WHAT HE HAD TOLD ME, THAT MY IDEAS FOR BUILDING A TIME PORTAL WAS FAR FROM BEING PERFECTED. HE SAID THAT I WAS DOING IT ALL WRONG AND THAT MY PORTAL WAS MISSING SOME PIECES. AFTER WHICH, HE THEN GAVE ME THE INFORMATION FOR THE CONSTRUCTION OF A TIME PORTAL WHICH HE CLAIMED WOULD ACTIVATE IN LESS THAN 3 MINUTES, PROVIDED OF COURSE THAT THE TIME PORTAL WAS BUILT OVER A NATURAL (GRID) POINT. SO BASICALLY THE INFORMATION WHICH I AM ABOUT TO REVEAL, WAS GIVEN TO ME THROUGH THIS ANGEL, OR AT LEAST IN PART.

PARTS

THREE 8 FOOT X 3 INCH PVC TUBES

THREE 7 FOOT X 3 INCH PVC TUBES

FOUR 3 INCH IN DIAMETER PVC ELBOW CONNECTORS

FOUR 3 INCH IN DIAMETER T-SHAPED PVC CONNECTORS

EIGHT 3 INCH IN DIAMETER PVC CAPS

20 POUNDS OF 21 GAGE MAGNET WIRE

ONE 200,000 VOLT TESLA COIL

ONE ROLL OF (PERMACEL) TAPE

TWO (COPPER) PYRAMID SPARK GAPS (FOR TESLA COIL)

ONE PHENOLIC RUBBING PLATE OR PENDULUM

AS YOU WILL SEE ON PAGES (8) AND (9), THE PVC ELBOW CONNECTORS ARE FASTENED TO THE UPPER LEFT AND RIGHT HAND CORNERS OF EACH OF THE VERTICAL AND HORIZONTAL PVC TUBES. THE T-SHAPED PVC CONNECTORS ARE FASTENED TO THE BOTTOM OF EACH OF THE VERTICAL PVC TUBES TO ACT AS A SUPPORT STAND. AS FOR THE PVC CAPS, THESE ARE FASTENED TO THE ENDS OF EACH OF THE T-SHAPED PVC CONNECTORS TO HELP SEAL THE TUBULAR CHAMBERS.

WHEN WRAPPING THE TUBES WITH THE 21 GAGE MAGNET WIRE, MAKE CERTAIN THAT THE COILS OF WIRE ARE WRAPPED AS CLOSE TOGETHER AS POSSIBLE, MUCH IN THE SAME WAY THAT YOU WOULD WRAP AN ELECTROMAGNET. REMEMBER! EVERY SQUARE INCH OF THE (TIME PORTAL) MUST BE COVERED WITH WIRE, AS WELL AS EACH OF THE 4 ELBOW CONNECTORS. ALSO THE COILS OF WIRE SHOULD BE WRAPPED IN THE SAME DIRECTION AS THE COILS ON YOUR TESLA COIL. IN OTHER WORDS, IF THE COILS ON YOUR TESLA COIL ARE WRAPPED IN A ASCENDING COUNTER-CLOCKWISE ROTATION, THE COILS ON YOUR TIME PORTAL SHOULD ALSO BE WRAPPED IN THE SAME DIRECTION. ONCE THIS IS DONE, THE NEXT STEP TO TAKE, IS TO SECURE EACH ROW OF COILS WITH A STRIP OF PERMACEL TAPE SO THAT THE COILS OF WIRE DO NOT BECOME UNRAVELED. HOWEVER MOST ANY TYPE OF TAPE WILL DO, BUT TESTS HAVE SHOWN THAT (PERMACEL) IS THE BEST.

IF YOU HAVE MADE IT THIS FAR, THEN ALL YOU HAVE LEFT TO DO, IS TO HOOK UP THE 2 WIRES WHICH EXTEND FROM THE TIME PORTAL, TO THE BRASS OR COPPER BALL ON TOP OF YOUR TESLA COIL. WHEN DOING THIS, MAKE DAM CERTAIN THAT THE TESLA COIL IS NOT ACTIVATED, OTHERWISE YOU COULD GET SHOCKED!!!

FRONT VIEW OF HYPER SPACE TIME PORTAL

(8)

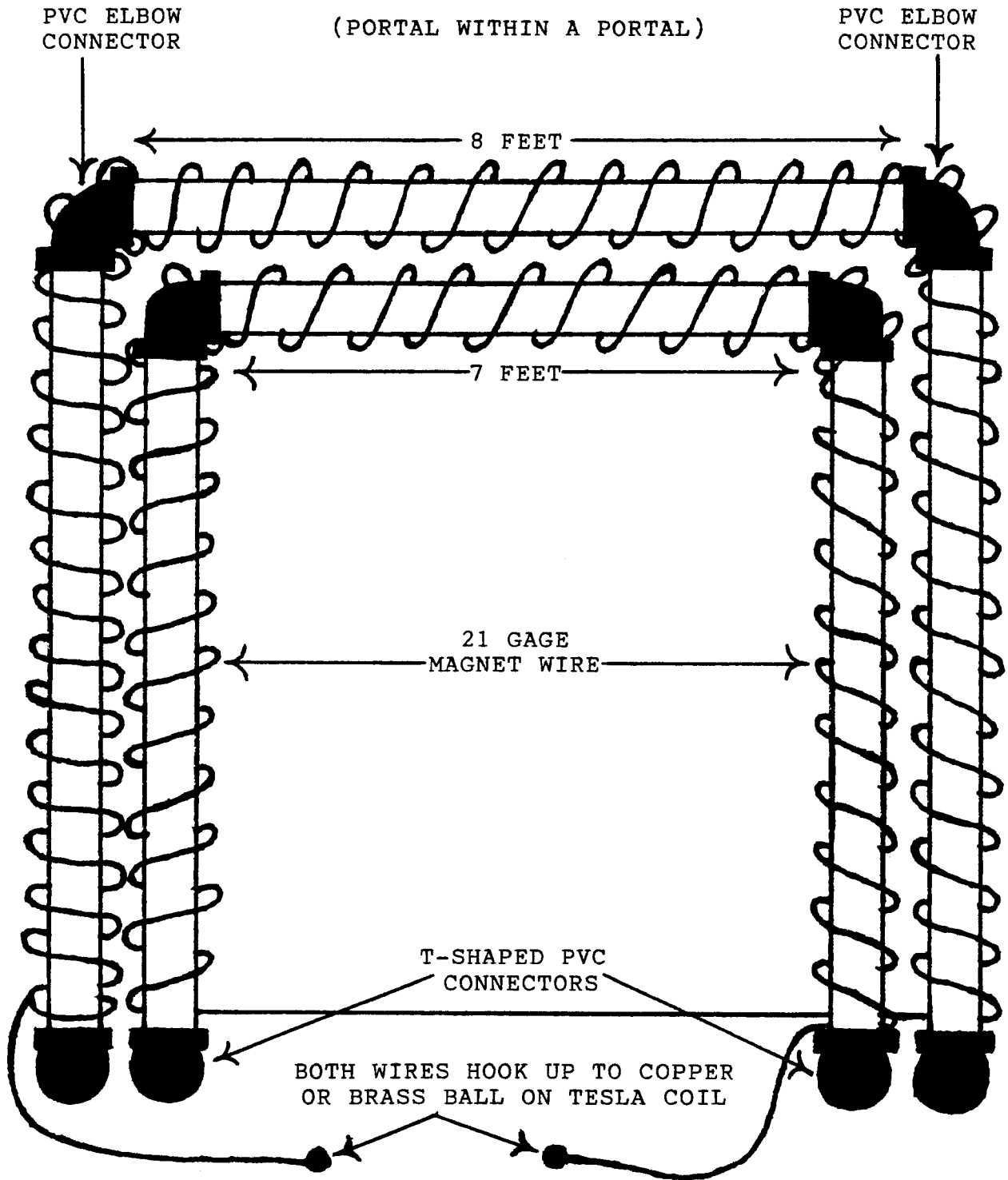

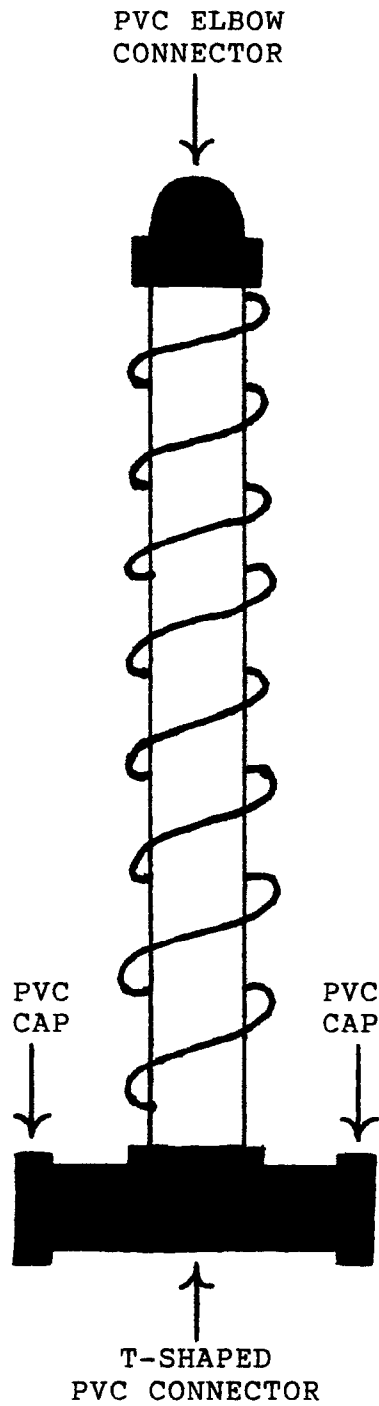

AT THIS POINT IT SHOULD ALSO BE MENTIONED, THAT THE BRASS OR COPPER SPARK GAPS WHICH ARE LOCATED INSIDE OF THE TESLA COIL, SHOULD BE REPLACED BY A SET OF COPPER OR GOLD PYRAMID SPARK GAPS. COPPER IS GOOD BUT GOLD IS THE BEST.

WHEN CONSTRUCTING THESE GOLD OR COPPER PYRAMID SPARK GAPS, THE FOLLOWING EQUATION SHOULD BE USED:-

$$(L/2, 1.618 = \phi)$$

IN OTHER WORDS, IF THE LENGTH OF THE BASE LINE IS DIVIDED BY (2), AND THE SUM OF WHICH IS THEN MULTIPLIED BY (1.618), THIS WILL GIVE YOU THE LENGTH FROM THE CENTER OF THE BASE LINE TO THE APEX FOR ONE OF THE (4) TRIANGLES WHICH MAKE UP THE STRUCTURE OF THE PYRAMID. (SEE BELOW)

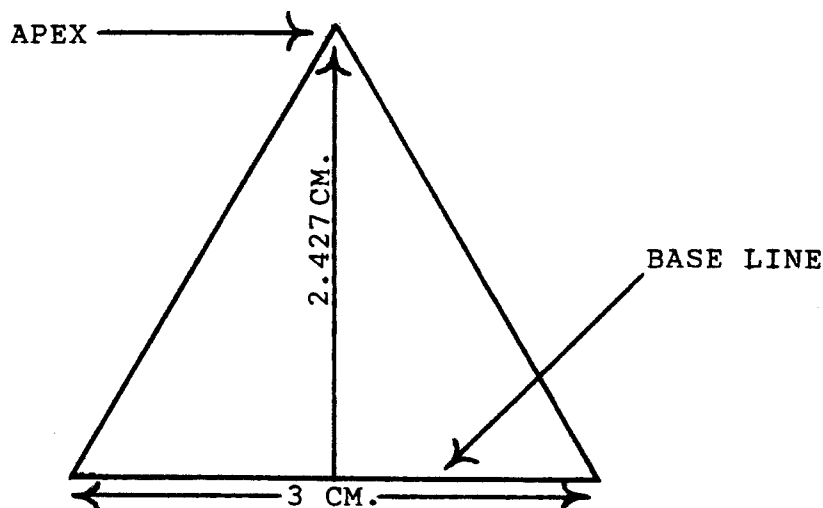

*NOTE: WHEN USING THIS FORMULA, THE METRIC STANDARD OF MEASUREMENT SHOULD BE USED. IF INCHES ARE USED IN PLACE OF CENTIMETERS, THEN THE PYRAMID BEING USED WILL NOT LOCK ONTO THE (ZERO VECTOR). AFTER THE PYRAMIDS ARE BUILT, IT MAY ALSO BE A GOOD IDEA TO BLESS EACH OF THEM WITH SALT WATER, IN THE NAME OF THE (FATHER), (SON), AND THE (HOLY GHOST).

NOW BEFORE YOU ATTEMPT TO ACTIVATE THE HYPER SPACE TIME PORTAL, I STRONGLY SUGGEST THAT YOU SPRINKLE EACH OF THE (PVC) TUBES WITH SALT WATER, AND AT THE SAME TIME BLESSING THEM IN THE NAME OF THE (FATHER), (SON), AND THE (HOLY GHOST). THE REASON FOR DOING THIS IS BECAUSE, IF YOU DON'T (CONSECRATE) THE TIME PORTAL WITH SALT WATER, THERE IS A DANGER OF BEING ATTACKED BY SOME SORT OF DEMON, DEVIL, OR EVIL SPIRIT. THEREFORE, IF YOUR NOT PROPERLY PROTECTED, AND SOMETHING NEGATIVE COMES THROUGH THAT TIME PORTAL, YOUR SCREWED BUDDY!!!

AFTER YOU HAVE TAKEN THE NECESSARY PRE-CAUTIONS, ACTIVATE THE TESLA COIL, AND WHILE YOU ARE STROKING THE RUBBING PLATE, AND AT THE SAME TIME ADJUSTING THE (PYRAMID SPARK GAPS), CONCENTRATE ON THE FOLLOWING QUESTION:- WHAT IS THE SPARK GAP SETTING WHICH WILL OPEN UP A DOORWAY TO (MONTH), (DAY), AND (YEAR), THAT WILL BE IN ACCORDANCE WITH THE CREATOR'S WILL? NOW AS SOON AS YOUR FINGERS STICK ON THE RUBBING PLATE, THIS MEANS THAT THE (PYRAMID SPARK GAPS) ARE NOW IN RESONANCE WITH THE (ZERO VECTOR), OR IN OTHER WORDS: (THOUGHT X TUNING = RESONANCE) AND (RESONANCE X RESONANCE = TIME). AT THIS POINT YOU STOP ADJUSTING THE (PYRAMID SPARK GAPS). SO BASICALLY, ALL YOU HAVE LEFT TO DO, IS TO WAIT FOR THE DOORWAY TO OPEN UP, AND IF YOU'VE DONE EVERYTHING CORRECTLY, IT SHOULD ACTIVATE IN LESS THAN 3 MINUTES.

*NOTE: IN ORDER FOR THIS TIME PORTAL TO BE 100% AFFECTIVE, IT SHOULD BE ACTIVATED OVER A LARGE OR MAJOR GRID POINT, OR IN A PLACE WHERE UFO'S ARE SIGHTED.

THE DEVICE WHICH I AM ABOUT TO REVEAL, IS QUITE SIMILAR TO THE HYPER DIMENSIONAL RESONATOR WHICH I SELL THROUGH MY TIME TRAVEL CATALOG. THE ONLY DIFFERENCE IS THAT INSTEAD OF USING AN INSTRUMENT BOX, THE CIRCUIT IS PLACED INSIDE A PYRAMID CONSTRUCTED OUT OF (COPPER) AND (PLEXIGLASS).

NOW THE REASON FOR THE (COPPER) AND (PLEXIGLASS) PYRAMID IS BECAUSE, ACCORDING TO MY (GRAVITON) EQUATIONS WHICH ARE GIVEN IN MY REPORT TITLED: (TIME TRAVEL PHYSICS), IS THAT WHENEVER YOU COMBINE A PARAMAGNETIC FIELD WITH A DIAMAGNETIC FIELD, YOU HAVE A (CAPACITOR) WHICH AUTOMATICALLY LOCKS ONTO THE (ZERO VECTOR). AND NOT ONLY THAT, BUT SINCE THE PYRAMID AND CIRCUIT ARE ALSO IN TUNED WITH THE (ZERO VECTOR), THE AMPLIFICATION PROCESS IS DRAMATICALLY ENHANCED.

AS FOR THE (HYPER RESONATOR) CIRCUIT, SEE PAGE (13), THIS SHOULD BE PLACED ON AN ELEVATED PLATFORM APPROXIMATELY (1/3) IN HEIGHT FROM THE BOTTOM OF THE BASE LINE TO THE APEX. SEE PAGE (14). IF THIS IS NOT DONE CORRECTLY, THE CIRCUIT WHICH IS PLACED ON THE PLATFORM, WILL NOT BE ABLE TO PICK UP THE PAST OR FUTURE TIME HARMONICS WHICH INTERSECT THE PYRAMID AT THIS POINT. ALSO, WHEN CONSTRUCTING THE PYRAMID, THE (PLEXIGLASS) PLATES SHOULD BE PLACED ON THE OUTER PART OF THE PYRAMID SO THAT THE COPPER PLATES WHICH ARE GLUED TO THE OTHER SIDE, ARE POINTING TOWARDS THE INNER CHAMBER. HOWEVER, IF THESE PLATES ARE REVERSED, IT COULD CAUSE SOME SERIOUS HEALTH PROBLEMS. THEREFORE UNDER NO CIRCUMSTANCES SHOULD THE COPPER PLATES BE PLACED ON THE OUTER PART OF THE PYRAMID.

5/8/95

HYPHER RESONATOR CIRCUIT

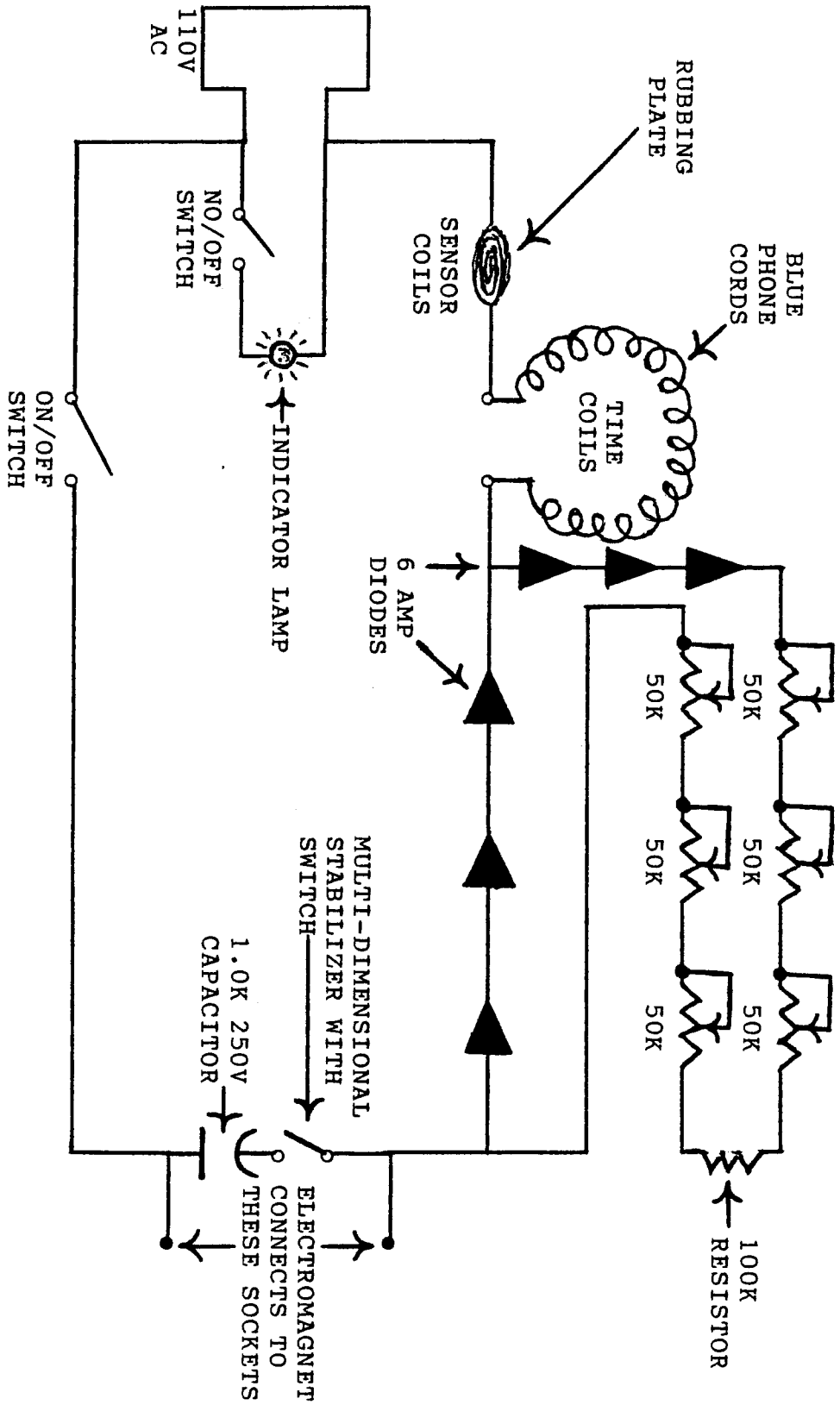

HOW THE TIME LINES INTERSECT THE MULTI-VERSE RESONATOR

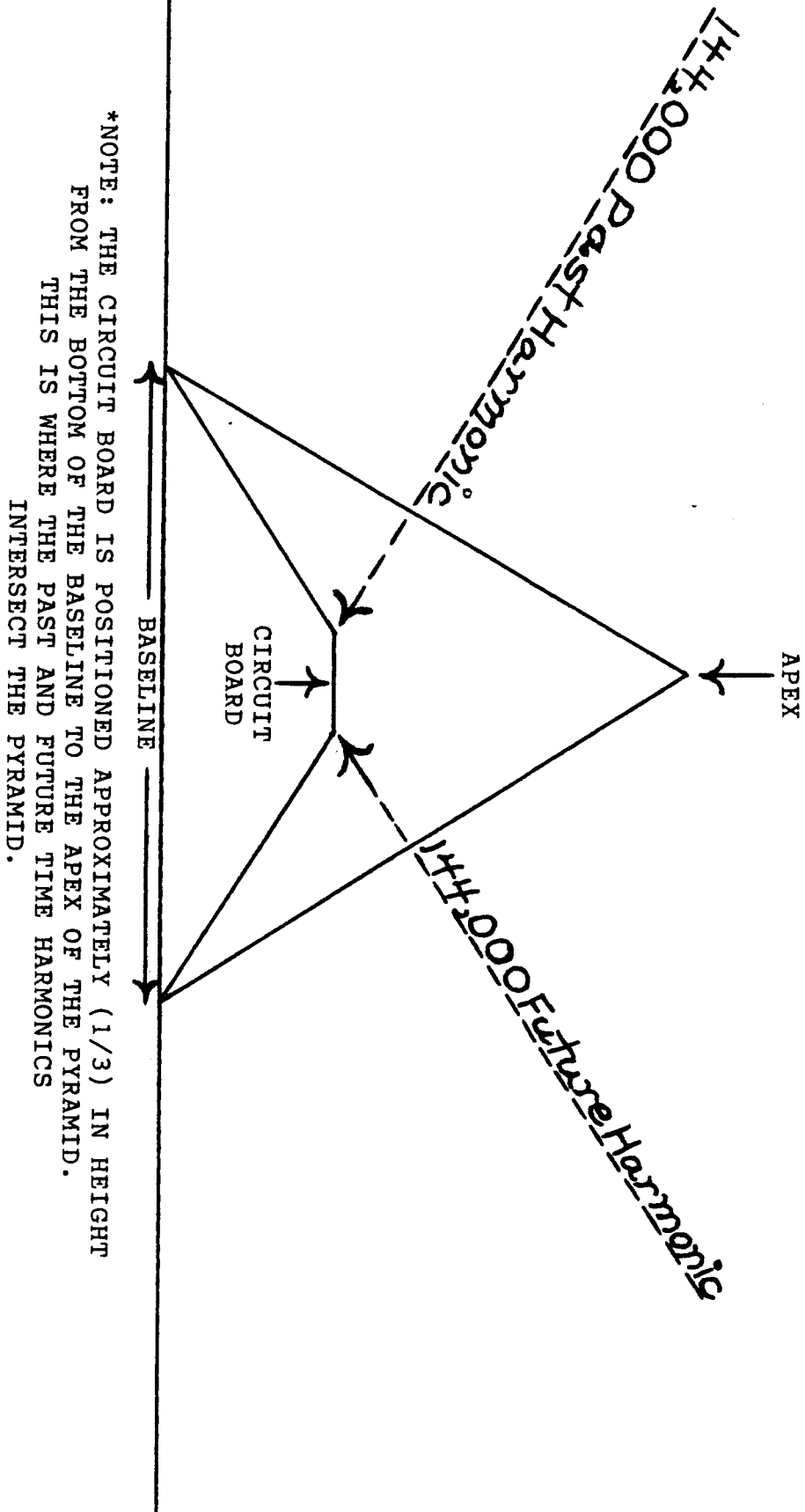

*NOTE: THE CIRCUIT BOARD IS POSITIONED APPROXIMATELY (1/3) IN HEIGHT FROM THE BOTTOM OF THE BASELINE TO THE APEX OF THE PYRAMID. THIS IS WHERE THE PAST AND FUTURE TIME HARMONICS INTERSECT THE PYRAMID.

AS I STATED EARLIER, THE (PLEXIGLASS) PLATES SHOULD BE PLACED ON THE OUTER PART OF THE PYRAMID SO THAT THE (COPPER) PLATES WHICH ARE GLUED TO THE OTHER SIDE, ARE POINTING TOWARDS THE (INNER CHAMBER). TO ILLUSTRATE HOW THIS SHOULD BE DONE, SEE PAGE (16). AS FOR THE SENSOR COILS WHICH CONNECT TO THE (HYPER RESONATOR CIRCUIT) WHICH IS SHOWN ON PAGE (13), THESE SHOULD BE WOUND IN THE FOLLOWING MANNER:-

(SENSOR COILS)

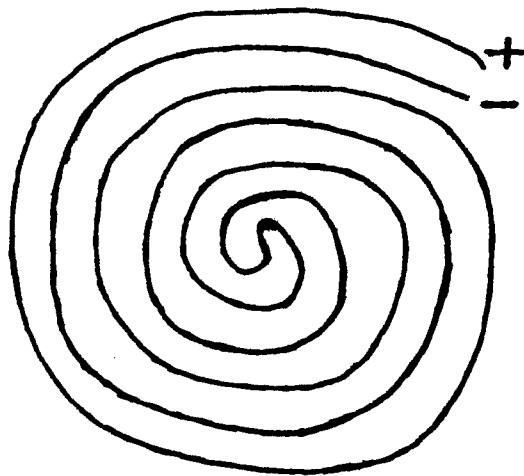

AFTER THE (SENSOR COILS) HAVE BEEN WOUND USING 20 GAGE SPEAKER WIRE, THIS (BI-FILLER) WINDING SHOULD BE GLUED TO ONE OF THE COPPER TRIANGULAR PLATES ON THE EAST OR WEST WALL OF THE (INNER CHAMBER). WHEN DOING THIS THE (SENSOR COILS) SHOULD BE PLACED BELOW THE (6) POTENTIOMETERS WHICH CONNECT TO THE CIRCUIT. SEE PAGE (17).

ONCE COMPLETED, THE (PLEXIGLASS) PANEL WHICH IS LOCATED DIRECTLY ABOVE THE (SENSOR COILS), MAY BE USED AS A RUBBING PLATE SO THAT ONCE YOUR FINGERS STICK, THE (SENSOR COILS) WILL PICK UP AN AMPLIFY YOUR SOUL ENERGIES.

COPPER AND PLEXIGLASS PLATES

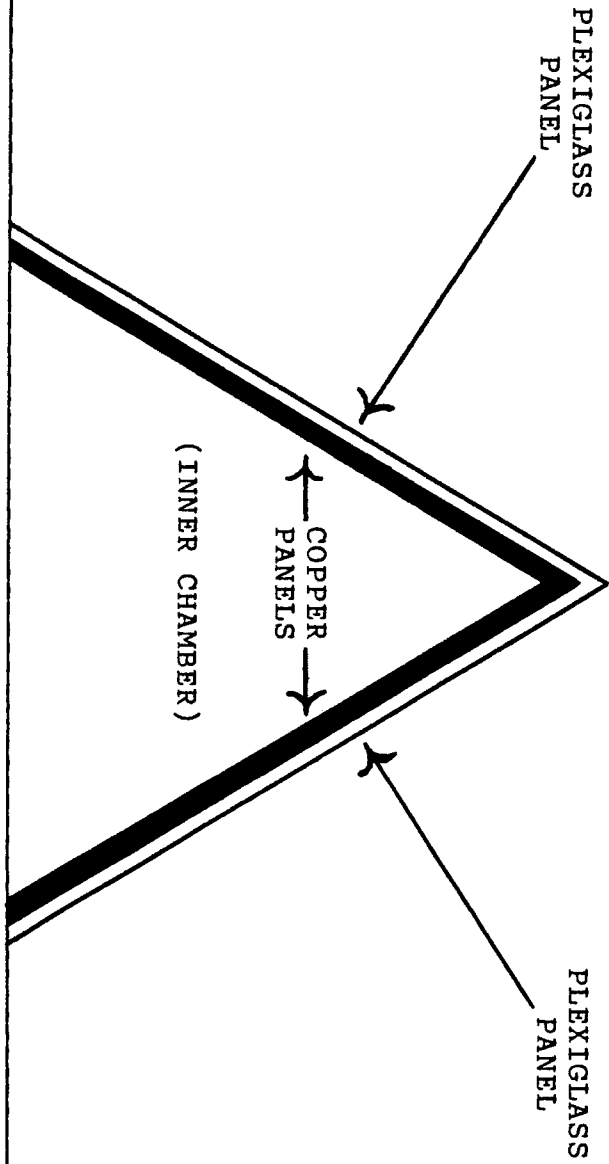

*NOTE: THE PLEXIGLASS AND COPPER PANELS MUST BE GLUED TOGETHER.

DIAGRAM TO ILLUSTRATE WHERE THE SENSOR COILS
ARE PLACED IN THE MULTI-VERSE RESONATOR

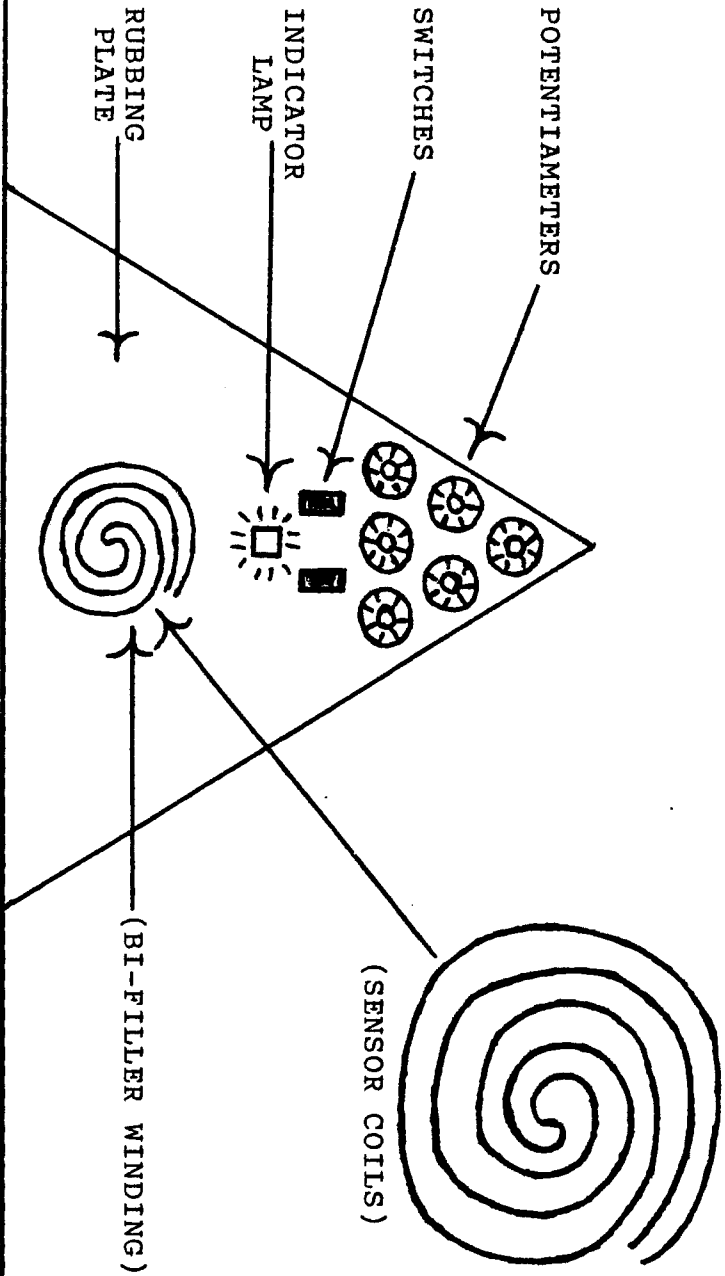

*NOTE: THE (SENSOR COILS) OR (BI-FILLER WINDING) IS GLUED TO THE COPPER TRIANGULAR PLATE WHICH POINTS TOWARDS THE INNER CHAMBER.

AFTER EVERYTHING HAS BEEN ASSEMBLED AND MOUNTED, THE MULTI-VERSE RESONATOR WILL LOOK SOMETHING LIKE THE DRAWING WHICH IS SHOWN ON PAGE (19). IF YOU WILL NOTE, IT DOES NOT MATTER WHERE THE (ELECTROMAGNET) OR (TIME COILS) ARE CONNECTED TO THE PYRAMID. HOWEVER, BEFORE THE (MULTI-VERSE RESONATOR) CAN FUNCTION PROPERLY, THE FLAT SIDES OF THE PYRAMID SHOULD BE POINTING TOWARDS MAGNETIC (NORTH) AND MAGNETIC (SOUTH). IF YOU FAIL TO DO THIS, THE PYRAMID WILL NOT BE ABLE TO PICK UP THE (PAST) OR (FUTURE) TIME HARMONICS. THE DRAWING ON PAGE (20) SHOULD MORE THAN ILLUSTRATE HOW THIS SHOULD BE DONE. IF YOU ARE HAVING SOME PROBLEMS IN GETTING THE RIGHT TYPE OF ALIGNMENT, JUST GET YOURSELF A COMPASS.

AS FAR AS THE COMPONENTS ARE CONCERNED, MOST OF THESE ITEMS CAN BE OBTAINED THROUGH YOUR LOCAL RADIO SHACK STORE. AS FOR THE (PLEXIGLASS) PANELS, A (GLASS SHOP) THAT SPECIALIZES IN CUTTING GLASS SHOULD BE ABLE TO HELP YOU OUT, ESPECIALLY IF YOU NEED THE PANELS CUT TO SPECIFIC SIZES. IF YOU ARE HAVING SOME TROUBLE IN THIS AREA, DON'T BE SURPRISED, SOME OF THESE ITEMS ARE EXTREMELY DIFFICULT TO GET A HOLD OF, ESPECIALLY THE COPPER PLATES. THE ONLY SOURCE I KNOW OF FOR COPPER SHEETING IS THE (AMERICAN SCIENCE AND SURPLUS) COMPANY. THEY USUALLY STOCK HARD TO FIND ITEMS. IF YOU WISH TO HAVE ONE OF THEIR CATALOGS, THEIR PHONE NUMBER IS:- (708) 982-0870. THE PHONE CORDS WHICH ARE USED FOR THE (TIME COILS), CAN BE OBTAINED THROUGH (MARLIN P. JONES & ASSOC. INC.). THEIR PHONE NUMBER IS:- (407) 848-8236.

FULL SCALE DRAWING OF THE MULTI-VERSE RESONATOR
WITH TIME COILS AND ELECTROMAGNET

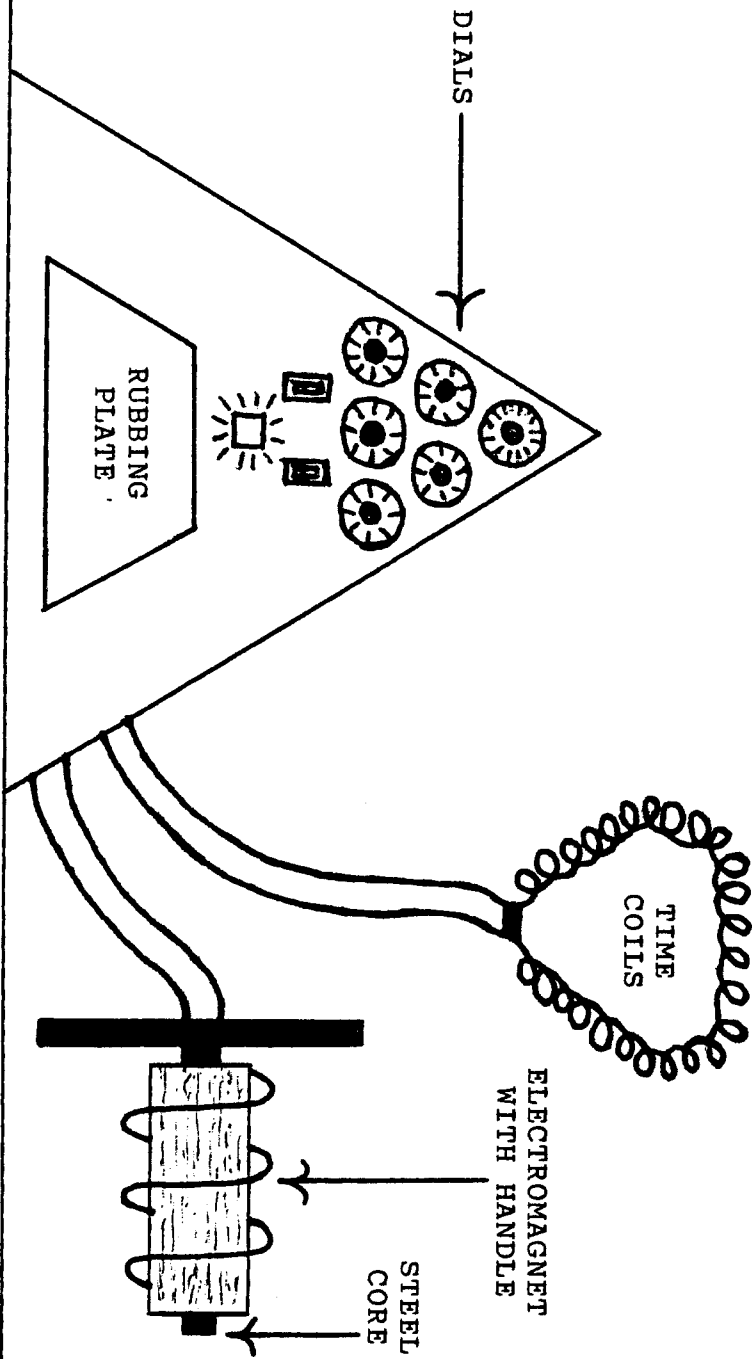

*NOTE: WHEN CUTTING THE (PLEXIGLASS) OR (COPPER) PANELS
THE PYRAMID EQUATION ON PAGE (10) MUST BE USED.

TOP VIEW OF MULTI-VERSE RESONATOR IN RELATION TO
MAGNETIC (NORTH) AND MAGNETIC (SOUTH)

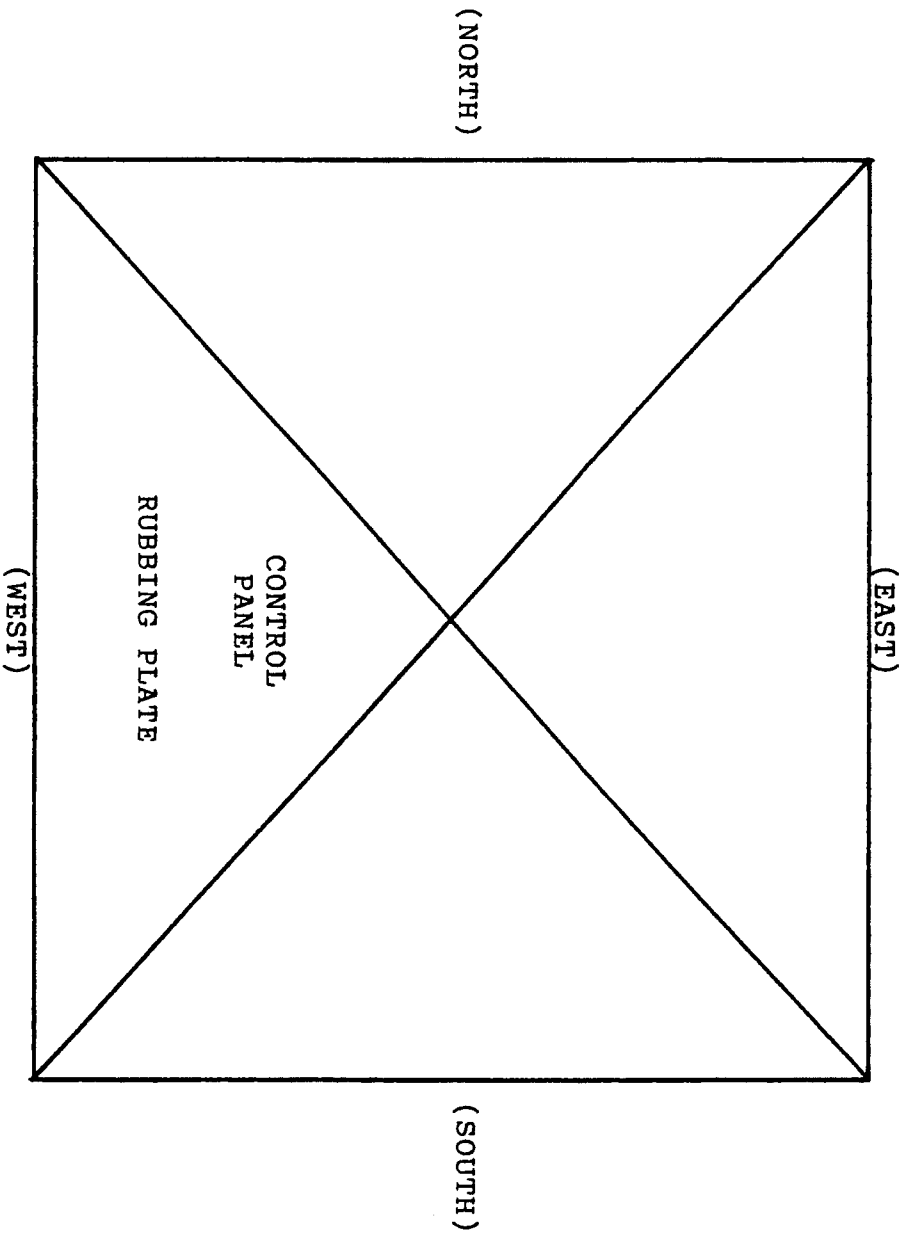

BEFORE WE CAN OPERATE THE (MULTI-VERSE RESONATOR), WE MUST FIRST DETERMINE IF THE OPEN END OF THE ELECTROMAGNET IS PROJECTING A (NORTH) OR (SOUTH) POLARIZED FIELD. SEE PAGE (22). TO DO THIS, WE MUST FIRST ACTIVATE THE HYPER RESONATOR CIRCUIT. NEXT, HOLD THE NORTH POLE SIDE OF A BAR MAGNET CLOSE TO THE OPEN END OF THE ELECTROMAGNET. SEE PAGE (23). IF THE BAR MAGNET IS REPELLED, THIS INDICATES THAT THE OPEN END OF THE ELECTROMAGNET IS PROJECTING A (NORTH) POLARIZED FIELD, WHICH IS BASICALLY THE FIELD THAT WE WANT TO USE. HOWEVER, SHOULD THE NORTH POLE SIDE OF THE BAR MAGNET BE ATTRACTED TO THE OPEN END OF THE ELECTROMAGNET, THEN THE WIRES FROM THE ELECTROMAGNET WHICH CONNECT TO THE PYRAMID MUST BE REVERSED. THE REASON FOR THIS BECOMES APPARENT, SINCE THE (NORTH) POLE GIVES LIFE AND THE (SOUTH) POLE DESTROYS. THEREFORE UNDER NO CIRCUMSTANCES SHOULD THE (SOUTH) POLE FIELD BE USED ON YOURSELF, OTHERWISE IT COULD LEAD TO SOME SERIOUS HEALTH PROBLEMS. BUT ANYHOW, AFTER YOU HAVE DETERMINE THE POLARITIES, AND WHILE THE (TIME COILS) OR (PHONE CORDS) ARE POSITIONED AROUND YOUR HEAD, (I.E. OVER THE 3RD EYE REGION), STROKE THE RUBBING PLATE WITH YOUR FINGERS WHILE TURNING EACH OF THE KNOBS. WHILE YOU ARE DOING THIS, CONCENTRATE ON THE FOLLOWING QUESTION:- WHAT ARE THE RATES WHICH WILL TRANSPORT MY PHYSICAL BODY AND ALL OF ITS COMPONENTS TO (MONTH), (DAY), (YEAR). NOW AS SOON AS YOUR FINGERS STICK WHILE TURNING THE FIRST DIAL, THIS MEANS THAT YOU HAVE HIT THE CORRECT RATE. YOU NOW PROCEED TO THE NEXT DIAL AND DO THE SAME THING AS BEFORE. AFTER ALL THE

DETAILED VIEW OF ELECTROMAGNET

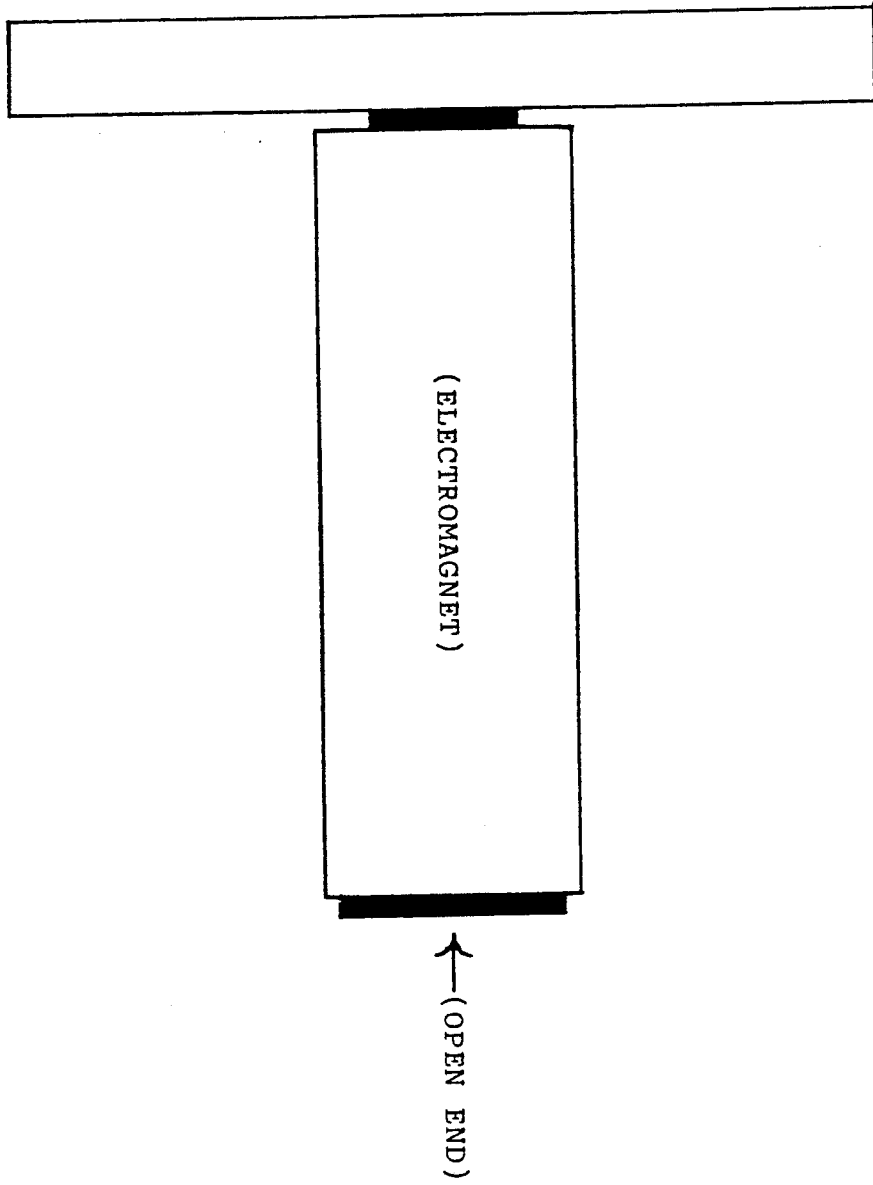

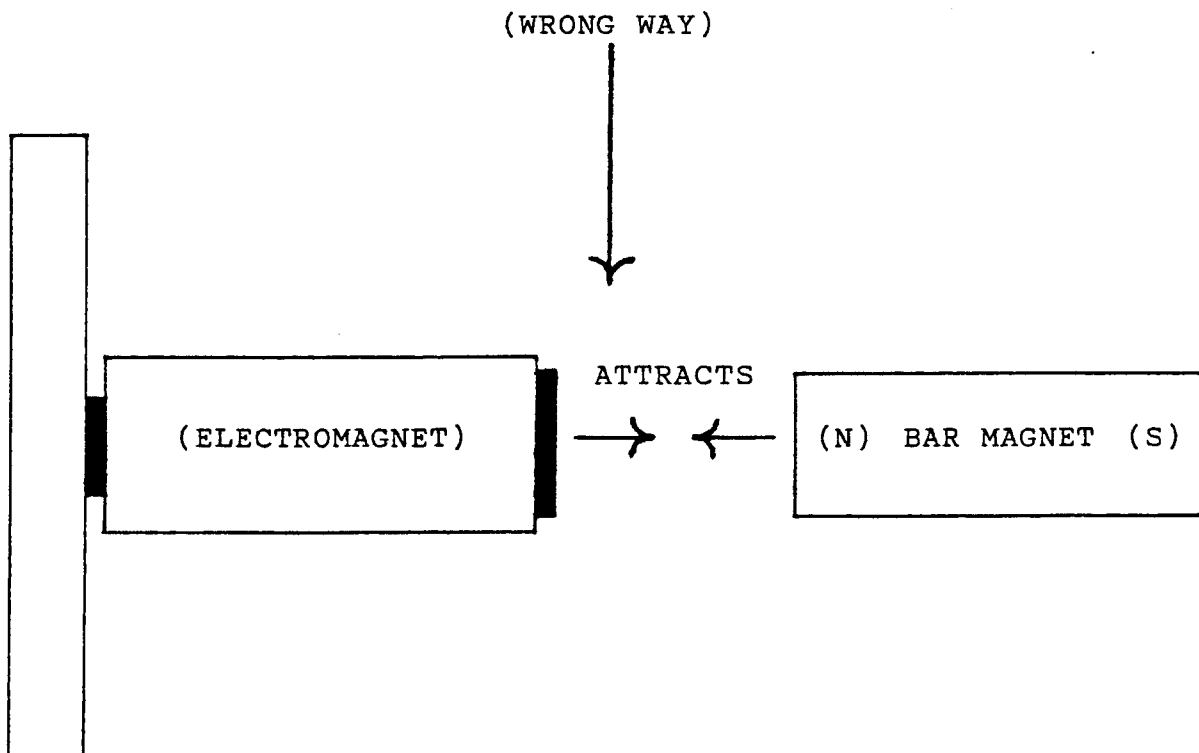
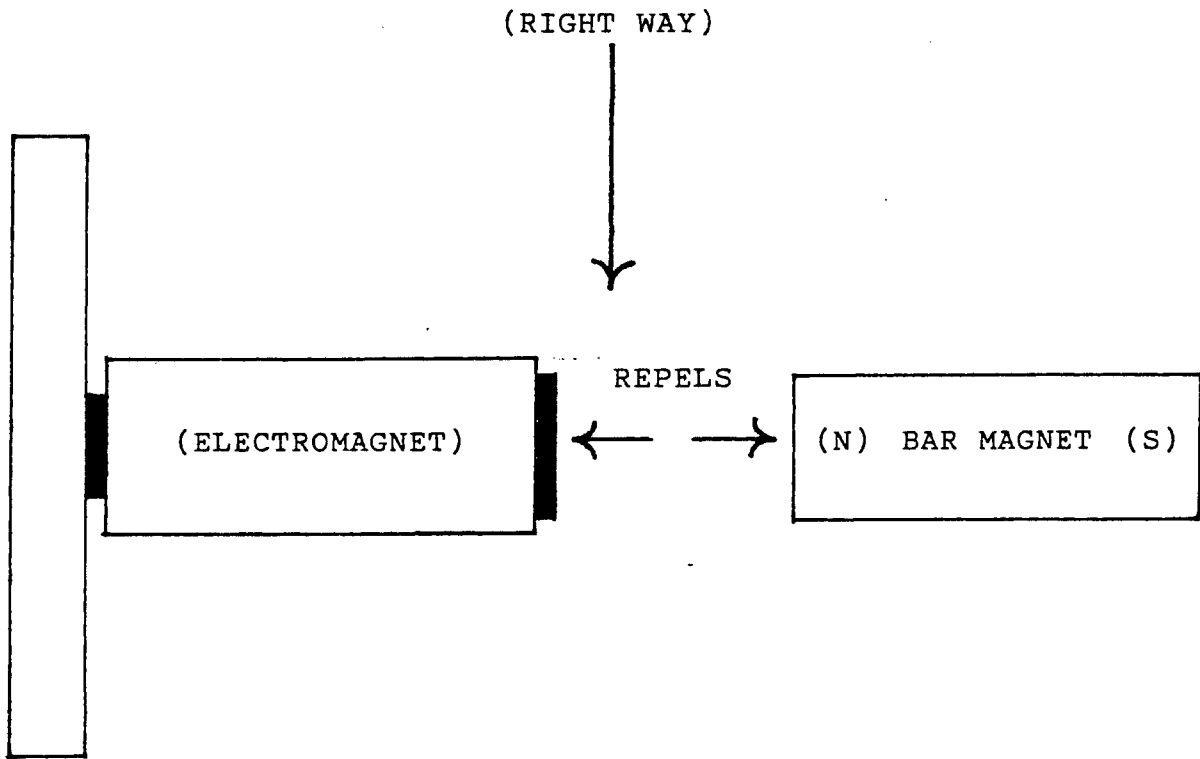

DIALS HAVE BEEN RADIONICALLY TUNED, ACTIVATE THE MULTI-VERSE RESONATOR. NEXT, POSITION THE OPEN END OF THE ELECTROMAGNET OVER THE (STOMACH CHAKRA) OR (NAVEL AREA). IF YOU'VE DONE EVERYTHING CORRECTLY, YOU SHOULD BE TRANSPORTED PHYSICALLY THROUGH TIME IN LESS THAN 3 MINUTES. HOWEVER THIS MAY VARY FROM PERSON TO PERSON. IT IS INTERESTING TO NOTE, THAT THIS PARTICULAR UNIT DOES NOT REQUIRE A (GRID POINT) TO TRAVEL PHYSICALLY THROUGH TIME AS:-

THOUGHT X TUNING = RESONANCE

RESONANCE X RESONANCE = TIME

SO BASICALLY, SINCE THERE ARE 2 POINTS OF RESONANCE WITHIN THE (MULTI-VERSE RESONATOR), TELEPORTATION THROUGH TIME CAN NOW BE EASILY ACHIEVED.

IT SHOULD ALSO BE ADDED, THAT TIME TRAVEL WITHOUT THE USE OF A GRID POINT IS IN MY OPINION SOMEWHAT DANGEROUS. THE REASON FOR THIS IS BECAUSE, A GRID POINT INSURES THAT YOUR JOURNEY WILL BE SAFE, WHEREAS WITHOUT ONE, YOU COULD END UP ANYWHERE, EVEN INSIDE OF A SOLID OBJECT! SO PEOPLE IF YOU DON'T ACTIVATE THE MULTI-VERSE RESONATOR OVER A LARGE OR MAJOR GRID POINT, YOU MAY GET TOASTED LIKE A HOT DOG!!!

ALSO, IF A GRID POINT IS USED, MAKE CERTAIN THAT THE AREA HAS BEEN BLESSED AND CONSECRATED WITH SALT WATER. IN OTHER WORDS, ASK THE LORD TO BLESS THE AREA, THEN WITH SOME (SALT) WATER SPRINKLE THE AREA IN THE NAME OF THE (FATHER), (SON), AND THE (HOLY GHOST). AS I'VE STATED BEFORE, IF YOU'VE DONE EVERYTHING CORRECTLY, YOU SHOULD BE PROTECTED.

THE (SPACE TIME COLLECTOR) WHICH IS SHOWN ON PAGE (26), IS STILL SOMEWHAT IN THE EXPERIMENTAL STAGES. HOWEVER IF YOU DO DECIDE TO BUILD IT, I THINK YOU WILL BE IN FOR SOME INTERESTING EXPERIENCES. AS FOR THE COMPONENTS, MOST OF THESE ITEMS CAN BE OBTAINED THROUGH YOUR LOCAL RADIO SHACK STORE, EXCEPT FOR THE (BAR MAGNETS) OR (RUBBING PLATE). THE (BAR MAGNETS) CAN BE PURCHASED THROUGH THE (AMERICAN SCIENCE AND SURPLUS) COMPANY. SEE PAGE (18). AND A (COPPER CLAD) CIRCUIT BOARD MAY BE USED IN PLACE OF THE (COPPER PLATE). SO BASICALLY YOU SHOULDN'T RUN INTO TO MANY DIFFICULTIES WHEN BUILDING THIS CIRCUIT. BUT IF YOU DO, JUST WRITE OR CALL ME.

OPERATION

THIS DEVICE IS PRETTY MUCH TUNED IN THE SAME WAY THAT YOU WOULD THE (MULTI-VERSE RESONATOR). IN OTHER WORDS, AFTER THE RATES HAVE BEEN FOUND FOR (TIME TRAVEL), ACTIVATE THE ON/OFF SWITCH, AND PLACE THE (COPPER PLATE) OVER YOUR (STOMACH) CHAKRA OR (NAVEL) AREA. IF YOU'VE DONE EVERYTHING CORRECTLY YOU SHOULD BE TRANSPORTED PHYSICALLY THROUGH TIME.

WARNING

BEFORE YOU OPERATE ANY OF THE DEVICES WHICH ARE LISTED IN THIS REPORT, MAKE CERTAIN THAT THE CIRCUIT HAS BEEN BLESSED AND CONSECRATED WITH SALT WATER. ALSO MAKE DAM CERTAIN THAT THE (GRID POINT) HAS BEEN CLEARED. SEE PAGE (24). IF YOU FAIL TO DO THIS, I WOULD HATE TO SAY WHAT MIGHT HAPPEN. THERE ARE MANY DANGERS OUT THERE WHICH FEW PEOPLE ARE AWARE OF. I WOULD HATE TO SEE ANYBODY GET HARASSED.

THE SPACE TIME COLLECTOR

