

P u r e W a t e r

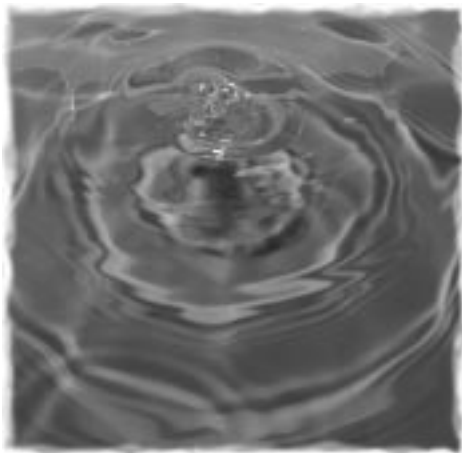

H a n d b o o k



OSMONICS

Osmonics Pure Water Handbook

2nd Edition



OSMONICS

5951 Clearwater Drive
Minnetonka, MN 55343-8995 USA
Phone (612) 933-2277
Fax (612) 933-0141

Property of:

© 1997, 1991 Osmonics, Inc.

Notice

Osmonics has made a serious effort to provide accurate information in this book. However, as in all publications, the possibility exists for errors and misprints in the text. Variations in data may also occur depending on field conditions. Information in this guide should only be used as a general guide. Osmonics does not represent the information as being exact. Please notify us of any errors, omissions or misprints in this book. Your suggestions for future editions will help to make this handbook as accurate and informative as possible.

History of Osmonics...

Osmonics was founded in 1969 by D. Dean Spatz as an industrially-oriented crossflow membrane company. The Company focused on bringing pioneering reverse osmosis/ultrafiltration (RO/UF) technology into the mainstream of fluid purification. In 1970, Osmonics manufactured its first spiral-wound membrane elements called sepalators, which have become the standard to which other RO/UF configurations are compared. Osmonics completed its initial public stock offering in October 1971 to finance equipment for membrane manufacturing.

Throughout the early 1970's, Osmonics pioneered a variety of membrane application firsts, including: the first sugar recovery unit; first system for reclaiming oily industrial wastes; first commercial UF for whey fractionation using spiral-wound membrane elements; first RO zero-discharge waste water treatment system; first RO for boiler feed pretreatment; first RO system to recover photography waste; and one of the first demonstrations of RO as a viable alternative to distillation for producing USP Water For Injection used in pharmaceutical manufacturing.

In 1977, Osmonics developed the TONKAFLO® pump for use in their RO/UF systems and created the TONKAFLO product line. This versatile pump also is being used to solve other industrial high-pressure pumping applications. In 1981, as the first phase of a long-term growth plan, a 100,000 sq. ft. manufacturing and headquarters facility was constructed on 40 acres of Company-owned land in Minnetonka, Minnesota. Osmonics acquired the HYTREX® disposable cartridge filter product lines from Celanese Corporation in 1983, and in 1984 acquired Flotronics from Selas Corporation, adding coalescers and a line of metallic and ceramic microfiltration filters to the Company's product offering. The acquisition of Aqua Media International and Aqua Media of Asia in 1985 expanded international sales and established a solid position in the growing Far East ultrapure water market.

In 1986, Osmonics invested in Poretics Corporation as a start-up company, manufacturing polycarbonate track-etch membrane and related laboratory microfiltration products. In 1994, the Company completed the acquisition of Poretics. The acquisition of American Pump Company in 1987 broadened the Company's pump line to include air-driven diaphragm pumps. Also acquired in 1987 was Vaponics, Inc., based in the Boston area, which expanded the Company's capabilities in high-quality ultrapure water equipment and systems especially for the pharmaceutical market.

Two acquisitions were completed in 1989: Ozone Research and Equipment Corporation, which added a very high quality, well-regarded ozonation product line; and MACE Products, offering a line of Teflon PTFE pumps and flow control components.

The FASTEK™ business was acquired in 1990 from Eastman Kodak. Products obtained include HRO spiral-wound membrane elements for home use, specialty rolled filters and melt-blown depth filters produced using a slightly different technology than the HYTREX melt-blown depth filters.

In 1991, Osmonics International was established as a Strategic Business Unit for direct marketing and sales activity for all international business, with emphasis in three primary regions: Europe, Asia/Pacific and Latin America.

In October, 1993, Osmonics acquired Autotrol Corporation, a leading manufacturer of valves, controls and measuring devices related to water treatment equipment. With the addition of Autotrol, international business grew to 30% of sales.

On January 11, 1994, Osmonics began trading on the New York Stock Exchange under the symbol OSM. The listing increased Osmonics' visibility as the broadest, most fully integrated water treatment company in the market.

Osmonics acquired Lakewood Instruments, a leading manufacturer of analytical instrumentation for water and waste treatment, in late 1994. The Lakewood product line broadens and strengthens the Company's existing instrumentation offerings, and enhances its ability to custom design control systems for complex applications.

In October 1995, Osmonics acquired Western Filter Company, the leading supplier of water treatment equipment to the beverage and bottled water market.

In 1996, Osmonics acquired Desalination Systems, Inc. of Vista, California, a primary manufacturer of membranes used for reverse osmosis, nanofiltration, ultrafiltration and microfiltration. These membranes are made into spiral-wound elements and sold worldwide. Osmonics' product line also includes spiral-wound membrane elements which will complement the Desal line.

Osmonics then acquired AquaMatic, Inc., of Rockford, Illinois, in early 1997. AquaMatic has been a leading supplier to the water purification industry for more than 60 years, and pioneered automatic water softener controls. Today, most water treatment equipment companies incorporate AquaMatic's unique non-metallic diaphragm valve in their products. AquaMatic's specialty valves and controllers will complement Osmonics' Autotrol product line.

For further information,
complete the postage-paid card at the back of this book
or call (800) 848-1750.



Table of Contents

	Page
1.0 Introduction	11
2.0 Water – The Problem of Purity	12
2.1 Natural Contamination and Purification	13
2.2 Bacterial Contamination	14
3.0 Identifying Impurities	15
3.1 General Qualitative Identification	15
Turbidity	15
Taste	16
Color	16
Odor	16
Further Analysis	16
3.2 General Quantitative Identification	17
pH	17
Total Solids	18
Conductivity/Resistivity	19
Microbiological Contamination	21
3.3 Specific Impurities	23
Common Ions	23
Dissolved Gases	28
Heavy Metals	28
Dissolved Organic Compounds	29
Volatile Organic Compounds (VOC)	29
Radioactive Constituents	29
4.0 Methods of Water Purification	30
4.1 Municipal or Utility Water Treatment	30
Screen Prefiltration	30
Clarification	30
Lime-Soda Ash Treatment	31
Disinfection	31
pH Adjustment	32
4.2 On-Site Treatment	32
Chemical Addition	32
Tank-Type Pressure Filters	34
Pre-Coat Filters	36
Cartridge Filters	37

	Page
Ion Exchange Systems	42
Organic Scavenging	48
Distillation and Pure Steam Generators	48
Electrodialysis	52
Crossflow Filtration Systems (Reverse Osmosis and Similar Processes)	53
Membrane Configurations	59
Disinfection – Control of Microbes	61
5.0 Examples of High-Purity Water Treatment Systems	68
5.1 Potable Water	68
Residential Water Purification System	68
5.2 Kidney Dialysis	70
Single-Patient Dialysis	70
15-Bed, In-Center Dialysis System, with Recycle	72
14-Bed, In-Center Dialysis, Continuous Flow Direct Feed	74
5.3 Commercial-Scale Purified Water Treatment System	76
5.4 Water for Pharmaceutical Use	78
USP Purified Water System	78
USP Water for Injection System	80
5.5 Boiler Feed and Power Generator Water	82
High-Pressure Steam Generation	84
5.6 Potable Water/Boiler Feed/Humidification/General Rinse	86
5.7 Water for Electronics	89
Ultrapure Water (18 megohm)	90
5.8 Water for Laboratory Use	92
Reagent-Grade Water for Laboratory Use	92
5.9 Water for Beverage Manufacturing	94
Bottled Water	94
Soft Drinks	94
Juices	95
Beverage Water Requirements	96
Bottled Water Requirements	98
6.0 Water Purification into the 21st Century	100

	Page
7.0 Appendices	101
7.1 Appendix A: U.S. National Drinking Water Regulations (as of February 1996)	101
7.2 Appendix B: Electronic Grade Water	106
7.3 Appendix C: Reagent-Grade Water	109
7.4 Appendix D: USP 23 WFI and Purified Water Standards	111
Water for Injection	111
Purified Water	111
7.5 Appendix E: Metric Conversions	116
7.6 Appendix F: Silt Density Index	117
7.7 Appendix G	119
Langelier Stability Indexes (LSI)	119
Nomograph for Determining Langelier or Ryznar Indexes	120
7.8 Appendix H	121
Effect of Bicarbonate Alkalinity and CO ₂ on pH	121
Effect of Mineral Acidity on pH	121
Effect of Carbonate and Bicarbonate Alkalinity on pH	122
7.9 Appendix I: Sieve Mesh Conversion Table	123
8.0 Glossary of Water Purification Terms	124

Terms appearing in **boldface type** throughout this Handbook's text also appear in the Glossary.

1.0 INTRODUCTION

For more than 30 years there has been remarkable growth in the need for quality water purification by all categories of users – municipal, industrial, institutional, medical, commercial and residential. The increasingly broad range of requirements for water quality has motivated the water treatment industry to refine existing techniques, combine methods and explore new water purification technologies.

Although great improvements have been made, myths and misconceptions still exist. This *Pure Water Handbook* by Osmonics will clear up common misconceptions and increase the reader's understanding of the capabilities of available technologies and how these technologies might be applied.

Science has found that there are no two water treatment problems exactly alike. There will always be slight differences with more than one technically -acceptable and scientifically-sound solution to any given water treatment problem. Beyond these two statements, there are no absolutes in water treatment.

2.0 WATER – THE PROBLEM OF PURITY

In its pure state, water is one of the most aggressive solvents known. Called the “universal solvent,” water, to a certain degree, will dissolve virtually everything to which it is exposed. Pure water has a very high energy state and, like everything else in nature, seems to achieve energy equilibrium with its surroundings. It will dissolve the quantity of material available until the solution reaches **saturation**, the point at which no higher level of solids can be dissolved. **Contaminants** found in water include atmospheric gases, minerals, organic materials (some naturally-occurring, others man-made) plus any materials used to transport or store water. The **hydrologic cycle** (Figure 1) illustrates the process of contamination and natural purification.

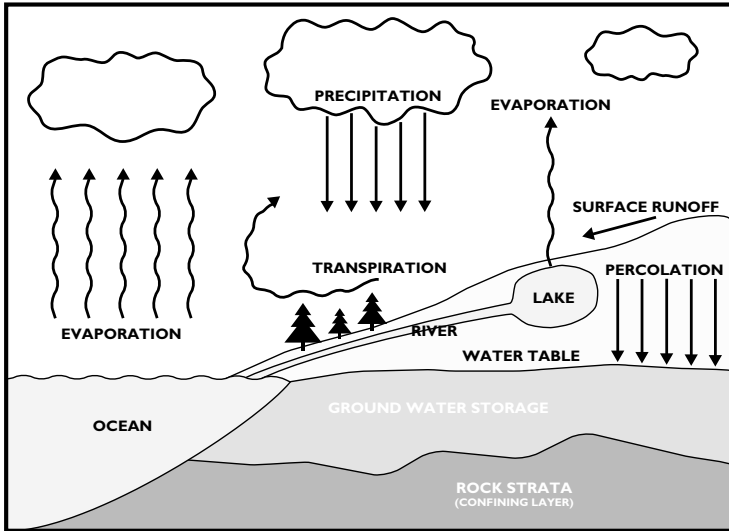

Figure 1 – Hydrologic Cycle

2.1 Natural Contamination and Purification

Water **evaporates** from surface supplies and **transpires** from vegetation directly into the atmosphere.

The evaporated water then condenses in the cooler air on nuclei such as dust particles and eventually returns to the earth's surface as rain, snow, sleet, or other **precipitation**. It dissolves gases such as carbon dioxide, oxygen, and natural and industrial emissions such as nitric and sulfuric oxides, as well as carbon monoxide. Typical rain water has a **pH** of 5 to 6. The result of contact with higher levels of these dissolved gases is usually a mildly acidic condition – what is today called “acid” rain – that may have a pH as low as 4.0.

As the precipitation nears the ground, it picks up many additional contaminants - airborne **particulates**, spores, **bacteria**, and emissions from countless other sources.

Most precipitation falls into the ocean, and some evaporates before reaching the earth's surface. The precipitation that reaches land replenishes **groundwater aquifers** and surface water supplies.

The water that percolates down through the **porous** upper crust of the earth is substantially “filtered” by that process. Most of the particulate matter is removed, much of the organic contamination is consumed by bacterial activity in the soil, and a relatively clean, mildly acidic solution results. This acidic condition allows the water to dissolve many minerals, especially limestone, which contributes calcium. Other geologic formations contribute minerals, such as magnesium, iron, sulfates and chlorides. The addition of these minerals usually raises groundwater pH to a range of 7 to 8.5.

This mineral-bearing water is stored in natural underground formations called aquifers. These are the source of the well water used by homes, industries and municipalities.

Surface waters such as rivers, lakes and reservoirs typically contain less mineral contamination because that water did not pass through the earth's soils. Surface waters will, however, hold higher levels of organics and undissolved particles because the water has contacted vegetation and caused runoff to pick up surface debris.

2.2 Bacterial Contamination

One difficulty of water purity is bacterial contamination and control of bacterial growth.

Water is essential for all life. It is a necessary medium for bacterial growth because it carries nutrients. It is an essential component of living cells. Its thermal stability provides a controlled environment. Water will support bacterial growth with even the most minute nutrient sources available.

3.0 IDENTIFYING IMPURITIES

The impact of the various impurities generated during the hydrologic cycle and/or bacterial colonization depends upon the water user's particular requirements. In order to assess the need for treatment and the appropriate technology, the specific contaminants must be identified and measured.

3.1 General Qualitative Identification

Qualitative identification is usually used to describe the visible or aesthetic characteristics of water. Among others these include:

- turbidity (clarity)
- taste
- color
- odor

Turbidity

Turbidity consists of suspended material in water, causing a cloudy appearance. This cloudy appearance is caused by the scattering and absorption of light by these particles. The suspended matter may be inorganic or organic. Generally the small size of the particles prevents rapid settling of the material and the water must be treated to reduce its turbidity.

Correlation of turbidity with the concentration of particles present is difficult since the light-scattering properties vary among materials and are not necessarily proportional to their concentration.

Turbidity can be measured by different optical systems. Such measurements simply show the relative resistance to light transmittance, not an absolute level of contamination.

A **candle turbidimeter** is a very basic visual method used to measure highly turbid water. Its results are expressed in Jackson Turbidity Units (**JTU**). A **nephelometer** is more useful in low-turbidity water, with results expressed in Nephelometric Turbidity Units (**NTU**) or Formazin Turbidity Units (**FTU**). JTU and NTU are not equivalent.

Suspended matter can also be expressed quantitatively in parts per million (**ppm**) by weight or milligrams per liter (**mg/L**). This is accomplished by gravimetric analysis, typically filtering the sample

through a 0.45-**micron** membrane disc, then drying and weighing the residue.

The Silt Density Index (**SDI**) provides a relative value of suspended matter. The measured values reflect the rate at which a 0.45-micron filter will plug with particulate material in the source water. The SDI test is commonly used to correlate the level of **suspended solids** in **feedwater** that tends to foul **reverse osmosis** systems.

Taste

The taste sense is moderately accurate and able to detect concentrations from a few tenths to several hundred ppm. However, taste often cannot identify particular contaminants. A bad taste may be an indication of harmful contamination in drinking water, but certainly cannot be relied on to detect all harmful contaminants.

Color

Color is contributed primarily by organic material, although some metal ions may also tint water. While not typically a health concern, color does indicate a certain level of impurities, and can be an aesthetic concern. “True color” refers to the color of a sample with its turbidity removed. Turbidity contributes to “apparent” color. Color can be measured by visual comparison of samples with calibrated glass ampules or known concentrations of colored solutions. Color can also be measured using a spectrophotometer.

Odor

The human nose is the most sensitive odor-detecting device available. It can detect odors in low concentrations down to parts per billion (**ppb**). Smell is useful because it provides an early indication of contamination which could be hazardous or at least reduce the aesthetic quality of the water.

Further Analysis

Further analysis should focus on identification and quantification of specific contaminants responsible for the water quality. Such contaminants can be divided into two groups: dissolved contaminants and particulate matter. Dissolved contaminants are mostly ionic atoms or a group of atoms carrying an electric charge. They are usually associated with water quality and health concerns. Particulate matter – typically silt, sand, virus, bacteria or color-causing particles – is not dissolved in water. Particulate matter is usually responsible

for aesthetic characteristics such as color, or parameters such as turbidity, which affects water processes.

3.2 General Quantitative Identification

Following are the major quantitative analyses which define water quality.

pH

The relative acidic or basic level of a solution is measured by pH. The pH is a measure of hydrogen **ion** concentration in water, specifically the negative logarithm (log) of the hydrogen ion concentration. The measurement of pH lies on a scale of 0 to 14 (Figure 2), with a pH of 7.0 being neutral (i.e., neither acidic nor basic), and bearing equal numbers of hydroxyl (OH⁻) and hydrogen (H⁺) ions. A pH of less than 7.0 is acidic; a pH of more than 7.0 is basic.

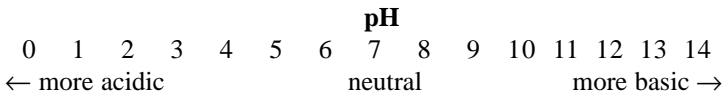

Figure 2 – pH Value

Since pH is expressed in log form, a pH of 6.0 is 10 times more acidic than a pH of 7.0, and a pH of 5.0 is 100 times more acidic than a pH of 7.0. The pH has an effect on many phases of water treatment such as coagulation, chlorination and water softening. It also affects the scaling-potential of water sources.

The pH level can be determined by various means such as color indicators, pH paper or pH meters. A pH meter is the most common and accurate means used to measure pH.

Total Solids

Total Solids (**TS**) (Table 1) is the sum of Total Dissolved Solids (**TDS**) and Total Suspended Solids (**TSS**). In water analysis these quantities are determined gravimetrically by drying a sample and weighing the residue. In the field, TDS is commonly measured by a conductivity meter (Figure 3) which is correlative to a specific salt solution; however, this measurement is only an approximation most often based on a multiplication factor of 0.66 of the electrical **conductivity**. (See Table 2 – page 20.)

Table 1 – Example Total Solids (TS)

TDS		TSS	
<u>Organic</u>	<u>Inorganic</u>	<u>Organic</u>	<u>Inorganic</u>
humic acid	reactive silica	algae	silt
tannin	(dissolved)	fungi	rust
pyrogens	salt ions	bacteria	floc
			clays

Conductivity/Resistivity

Ions conduct electricity. Because pure water contains few ions, it has a high resistance to electrical current. The measurement of water’s electrical conductivity, or **resistivity**, can provide an assessment of total ionic **concentration**. Conductivity is described in microSiemens/cm (μS) and is measured by a conductivity meter (Figure 4) and cell. Resistivity is described in megohm-cm, is the inverse of conductivity and is measured by a resistivity meter and cell.

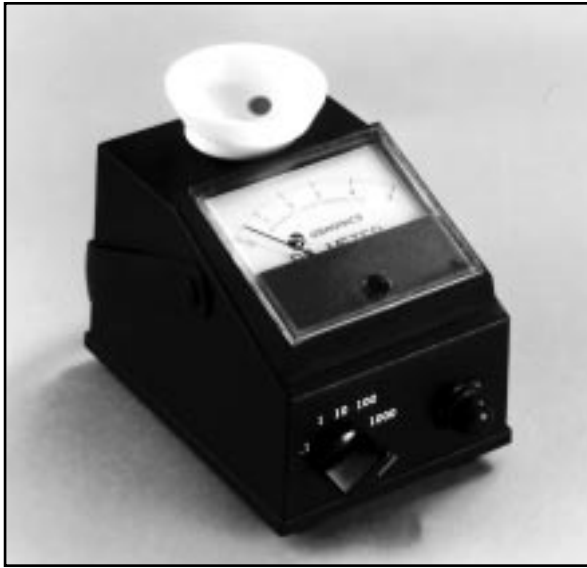

Figure 3 – Field Conductivity Meter



Figure 4 – On-Line Conductivity Meter

IDENTIFYING IMPURITIES

Table 2 expresses the relative concentrations of sodium chloride versus conductivity and resistance. As a general rule, ionic-dissolved content, expressed in ppm or mg/L, is approximately one-half to two-thirds the conductance of water. Other salt solutions are used and the curve varies. Monovalent salts have higher conductivities than multivalent salts.

Table 2 – Relative Concentration of Dissolved Minerals versus Conductivity and Resistance @ 25°C

mg/L Sodium Chloride	Total Dissolved Solids mg/L CaCO ₃	Specific Conductance MicroSiemens/cm	Specific Resistance ohms/cm	Grains per Gallon
0.05	0.043	0.105	9,523,800	0.0025
0.1	0.085	0.212	4,716,980	0.0049
0.2	0.170	0.424	3,558,490	0.0099
0.3	0.255	0.637	1,569,850	0.0149
0.4	0.340	0.848	1,179,240	0.0198
0.5	0.425	1.06	943,396	0.0248
0.6	0.510	1.273	785,545	0.0298
0.7	0.595	1.985	673,400	0.0347
0.8	0.680	1.696	589,622	0.0397
0.9	0.765	1.908	524,109	0.0447
1.0	0.85	2.12	471,698	0.0497
2.0	1.70	6.37	156,985	0.0994
4.0	3.40	8.48	117,924	0.1988
5.0	4.25	10.6	94,339	0.2485
6.0	5.10	12.73	78,554	0.2982
7.0	5.95	14.85	67,340	0.3479
8.0	6.80	16.96	58,962	0.3976
9.0	7.65	19.08	52,410	0.4473
10.0	8.5	21.2	47,169	0.4970
20.0	17.0	42.4	23,584	0.9941
30.0	25.5	63.7	15,698	1.4912
40.0	34.0	84.8	11,792	1.9883
50.0	42.5	106.0	9,433	2.4853
60.0	51.0	127.3	7,855	2.9824
70.0	59.5	148.5	6,734	3.4795
80.0	68.0	169.6	5,896	3.9766
90.0	76.5	190.8	5,241	4.4736

continued

IDENTIFYING IMPURITIES

100.0	85.0	212.0	4,716	4.9707
200.0	170.0	410.0	2,439	9.9415
300.0	255.0	610.0	1,639	14.9122
400.0	340.0	812.0	1,231	19.8830
500.0	425.0	1,008.0	992	24.8538
600.0	510.0	1,206.0	829	29.8245
700.0	595.0	1,410.0	709	34.7953
800.0	680.0	1,605.0	623	39.7660
900.0	765.0	1,806.0	553	44.7368
<hr/>				
1,000.0	850.0	2,000.0	500	49.7076
2,000.0	1,700.0	3,830.0	261	99.4152
3,000.0	2,550.0	5,670.0	176	149.1228
4,000.0	3,400.0	7,500.0	133	198.8304
5,000.0	4,250.0	9,240.0	108	248.5380
6,000.0	5,100.0	10,950.0	91	298.2456
7,000.0	5,950.0	12,650.0	79	347.9532
8,000.0	6,800.0	14,340.0	69	397.6608
9,000.0	7,650.0	16,000.0	62	447.3684
10,000.0	8,500.0	17,600.0	56	497.0760

Microbiological Contamination

Microbiological contamination can be classified as viable and nonviable. Viable organisms are those that have the ability to reproduce and proliferate. Nonviable organisms cannot reproduce or multiply.

• Bacterial Contamination

Bacterial contamination is quantified as “Colony Forming Units” (CFU), a measure of the total viable bacterial population. CFU’s are typically determined by incubating a sample on a nutritional medium and counting the number of bacterial colonies that grow. Each colony is assumed to have grown from a single bacterial cell. This is called a “Standard Plate Count” and is the most common method. Other less common methods of enumerating microbial contamination include the “Most Probable Number,” which is a statistical probability of the bacterial population in a small sample, and the “Direct Count,” which is an actual count of cells observed through a microscope.

• Pyrogenic Contamination

Pyrogens are substances that can induce a fever in a warm-blooded animal. The most common pyrogenic substance is the bacterial **endotoxin**. These endotoxins are lipopolysaccharide **compounds**

from the cell walls of gram-negative bacteria. They can be pyrogenic whether they are part of intact viable cells or simply fragments from ruptured cells. They are more stable than bacterial cells and are not destroyed by all conditions (such as autoclaving) that kill bacteria. Their **molecular weight** (MW) is generally accepted to be approximately 10,000. One molecular weight (MW) is approximately equal to one **dalton**. However, in aqueous environments they tend to agglomerate to larger sizes. Pyrogens are quantified as **Endotoxin Units** per milliliter (EU/mL).

The traditional method for pyrogen detection used live rabbits as the test organism. Today the most common method is the *Limulus* Amoebocyte Lysate (**LAL**) test. Endotoxins react with a purified extract of the blood of the horseshoe crab *Limulus polyphemus* and this reaction can be used to determine the endotoxin concentration. There are several versions of the LAL test ranging from the semi-quantitative “gel-clot method” to the fully-automated “kinetic turbidimetric method” which is sensitive to 0.001 EU/mL. There is an endotoxin limit in the pharmaceutical industry for **USP Water For Injection (WFI)** of 0.25 EU/mL. The LAL test is relatively quick and inexpensive.

The LAL test is used if there is a concern about endotoxins in the finished water, such as in pharmaceutical uses. However, due to the swift results and the relatively low cost of the LAL test, other industries with critical water quality needs are beginning to use it as a quick indicator of possible bacterial contamination or total organic carbon (**TOC**).

- **Total Organic Carbon (TOC)**

TOC is a direct measure of the organic, oxidizable, carbon-based material in water. TOC is a vital measurement used in sophisticated water treatment systems – such as electronics grade – where any amount of contamination can adversely affect product quality and yield.

- **Biochemical Oxygen Demand (BOD)**

BOD is a measure of organic material contamination in water, specified in mg/L. BOD is the amount of dissolved oxygen required for the biochemical decomposition of organic compounds and the oxidation of certain inorganic materials (e.g., iron, sulfites). Typically the test for BOD is conducted over a five-day period.

• **Chemical Oxygen Demand (COD)**

COD is another measure of organic material contamination in water specified in mg/L. COD is the amount of dissolved oxygen required to cause chemical **oxidation** of the organic material in water.

Both BOD and COD are key indicators of the environmental health of a surface water supply. They are commonly used in waste water treatment but rarely in general water treatment.

3.3 Specific Impurities

Many individual impurities can be quantified through water analysis techniques. Below is a discussion of most ionic individual contaminants.

Common Ions

A number of terms are used to express the level of mineral contamination in a water supply.

Table 3 – Units of Concentration

<u>Unit</u>	<u>Abbreviation</u>	<u>Describes</u>
milligrams per liter	mg/L	(weight per volume)
parts per million	ppm	(weight in weight)
parts per billion	ppb	(weight in weight)
parts per trillion	ppt	(weight in weight)
grains per gallon	gpg	(weight per volume)
milli-equivalents per liter	m eq/L	(weight per volume)

A conversion table (Table 4) illustrates the relationships.

Table 4 – Conversions

mg/L /17.1 = gpg
 ppm /17.1 = gpg
 gpg x 17.1 = ppm or mg/L
 mg/L (expressed as CaCO₃) x 50 = m eq/L
 ppm x 1000 = ppb
 ppb x 1000 = ppt

• Water Hardness

The presence of calcium (Ca^{2+}) and magnesium (Mg^{2+}) ions in a water supply is commonly known as “**hardness**.” It is usually expressed as **grains per gallon (gpg)**. Hardness minerals exist to some degree in virtually every water supply. The following table classifies the degree of hardness:

Table 5 – Water Hardness Classification

Hardness Level		Classification
mg/L	gpg	
0-17	<1	soft water
17-60	1-3.5	slightly hard water
60-120	3.5-7.0	moderately hard water
120-180	7.0-10.5	hard water
>180	>10.5	very hard water

The main problem associated with hardness is scale formation. Even levels as low as 5 to 8 mg/L (0.3 to 0.5 gpg) are too extreme for many uses. The source of hardness is calcium- and magnesium-bearing minerals dissolved in groundwater. “**Carbonate**” and “**noncarbonate**” **hardness** are terms used to describe the source of calcium and magnesium. “Carbonate” hardness usually results from dolomitic limestone (calcium and magnesium carbonate) while “noncarbonate” hardness generally comes from chloride and sulfate salts.

• Iron

Iron, which makes up 5% of the earth’s crust, is a common water contaminant. It can be difficult to remove because it may change valence states – that is, change from the water-soluble ferrous state (Fe^{2+}) to the insoluble ferric state (Fe^{3+}). When oxygen or an oxidizing agent is introduced, ferrous iron becomes ferric which is insoluble and so precipitates, leading to a rusty (red-brown) appearance in water. This change can occur when deep well water is pumped into a distribution system where it adsorbs oxygen. Ferric iron can create havoc with valves, piping, water treatment equipment, and water-using devices.

Certain bacteria can further complicate iron problems. Organisms such as *Crenothrix*, *Sphaerotilus* and *Gallionella* use iron as an energy source. These iron-reducing bacteria eventually form a rusty, gelatinous sludge that can plug a water pipe. When diagnosing an

iron problem, it is very important to determine whether or not such bacteria are present.

- **Manganese**

Although manganese behaves like iron, much lower concentrations can cause water system problems. However, manganese does not occur as frequently as iron. Manganese forms a dark, almost black, **precipitate**.

- **Sulfate**

Sulfate (SO_4^{2-}) is very common. When present at lower levels, sulfate salts create problems only for critical manufacturing processes. At higher levels, they are associated with a bitter taste and laxative effect. Many divalent metal-sulfate salts are virtually insoluble and precipitate at low concentrations.

- **Chloride**

Chloride (Cl^-) salts are common water contaminants. The critical level of chloride depends on the intended use of the water. At high levels, chloride causes a salty or brackish taste and can interfere with certain water treatment methods. Chlorides also corrode the metals of water supply systems, including some stainless steels.

- **Alkalinity**

Alkalinity is a generic term used to describe carbonates (CO_3^{2-}), bicarbonates (HCO_3^-) and hydroxides (OH^-). When present with hardness or certain heavy metals, alkalinity contributes to **scaling**. The presence of alkalinity may also raise the pH.

- **Nitrate - Nitrite**

Although nitrate (NO_3^-) and nitrite (NO_2^-) salts may occur naturally, their presence in a water supply usually indicates man-made pollution. The most common sources of nitrate/nitrite contamination are animal wastes, primary or secondary sewage, industrial chemicals and fertilizers. Even low nitrate levels are toxic to humans, especially infants, and contribute to the loss of young livestock on farms with nitrate-contaminated water supplies.

- **Chlorine**

Chlorine, because of its bactericidal qualities, is important in the treatment of most municipal water supplies. It is usually monitored as free chlorine (Cl_2) in concentrations of 0.1 to 2.0 ppm. In solution, chlorine gas dissolves and reacts with water to form the

hypochlorite **anion** (ClO^-) and hypochlorous acid (HClO). The relative concentration of each ion is dependent upon pH. At a neutral pH of 7, essentially all chlorine exists as the hypochlorite anion which is the stronger oxidizing form. Below a pH of 7, hypochlorous acid is dominant, and has better disinfectant properties than the anion counterpart. Although chlorine's microbial action is generally required, chlorine and the compounds it forms may cause a disagreeable taste and odor. Chlorine also forms small amounts of trihalogenated methane compounds (**THM's**), which are a recognized health hazard concern as **carcinogenic materials**. The organic materials with which the chlorine reacts are known as **THM precursors**.

• Chloramines

In some cases, chlorine is also present as **chloramine** (i.e., monochloramine, NH_2Cl) as a result of free chlorine reacting with ammonia compounds. The ammonia is added to a water supply to "stabilize" the free chlorine. Chloramines are not as effective a microbial deterrent as chlorine, but provide longer-lasting residuals.

• Chlorine Dioxide

This material is often produced on-site primarily by large municipalities via the reaction between chlorine or sodium hypochlorite and sodium chlorite. A more costly source of chlorine dioxide is available as a stabilized sodium chlorite solution. Chlorine dioxide has been used for taste and odor control and as an efficient biocide. Chlorine dioxide can maintain a residual for extended periods of time in a distribution system and does not form trihalomethanes (THM's) or chloramines if the stabilized sodium chlorite form is used. The possible toxicity of the chlorate and chlorite ions (reaction by-products) may be a concern for potable water applications.

• Silica

Every water supply contains at least some silica (SiO_2). Silica occurs naturally at levels ranging from a few ppm to more than 200 ppm. It is one of the most prevalent elements in the world. Among the problems created by silica are scaling or "**glassing**" in boilers, stills, and cooling water systems, or deposits on turbine blades. Silica scale is difficult to remove.

Silica chemistry is complex. An unusual characteristic of silica is its solubility. Unlike many scaling salts, silica is more soluble at higher pH ranges. Silica is usually encountered in two forms: ionic and **colloidal** (reactive and nonreactive based on the typical analytical

techniques). Silica can be present in natural waters in a combination of three forms: reactive (ionic), nonreactive (colloidal) and particulate.

– Ionic Silica (reactive)

Ionic or reactive silica exists in an SiO_2 complex. It is not a strongly-charged ion and therefore is not easily removed by **ion exchange**. However, when concentrated to levels above 100 ppm, ionic silica may polymerize to form a colloid.

– Colloidal Silica (nonreactive)

At concentrations over 100 ppm, silica may form colloids of 20,000 molecular weight and larger, still too small to be effectively removed by a particle filter. Colloidal silica is easily removed with **ultrafiltration**, or can be reduced by chemical treatment (lime softening).

Colloidal silica can lower the efficiency of filtration systems (such as reverse osmosis). Any silica can affect yields in semiconductor manufacturing and is a major concern in high-pressure boiler systems.

• **Aluminum**

Aluminum (Al^{3+}) may be present as a result of the addition of aluminum sulfate [$\text{Al}_2(\text{SO}_4)_3$] known as alum, a commonly used **floculant**. Aluminum can cause scaling in cooling and boiler systems, is a problem for dialysis patients, and may have some effects on general human health. Aluminum is least soluble at the neutral pH common to many natural water sources.

• **Sodium**

The sodium ion (Na^+) is introduced naturally due to the dissolution of salts such as sodium chloride (NaCl), sodium carbonate (Na_2CO_3), sodium nitrate (NaNO_3) and sodium sulfate (Na_2SO_4). It is also added during water softening or discharge from industrial brine processes. By itself the sodium ion is rarely a problem, but when its salts are the source of chlorides (Cl^-) or hydroxides (OH^-), it can cause corrosion of boilers, and at high concentrations (such as seawater) it will corrode stainless steels.

• **Potassium**

Potassium is an essential element most often found with chloride (KCl) and has similar effects but is less common than sodium chloride. It is used in some industrial processes. The presence of KCl is

typically a problem when only **ultrapure water** quality is required.

- **Phosphate**

Most phosphates (PO_4^{3-}) commonly enter surface water supplies through runoff of fertilizers and **detergents** in which “phosphates” are common ingredients. Phosphates also enter the hydrologic cycle through the breakdown of organic debris.

Phosphates are used in many antiscalant formulations. At the levels found in most water supplies phosphates do not cause a problem unless ultrapure water is required. Phosphates may foster algae blooms in surface waters or open storage tanks.

Dissolved Gases

- **Carbon Dioxide**

Dissolved carbon dioxide (CO_2) associates with water molecules to form carbonic acid (H_2CO_3), reducing the pH and contributing to corrosion in water lines, especially steam and **condensate** lines. Carbonic acid, in turn, dissociates to bicarbonate (HCO_3^-) or carbonate (CO_3^{2-}), depending on pH. Most of the CO_2 found in water comes not from the atmosphere but from carbonate that the water has dissolved from rock formations.

- **Oxygen**

Dissolved oxygen (O_2) can corrode water lines, boilers and heat exchangers, but is only soluble to about 14 ppm at atmospheric pressure.

- **Hydrogen Sulfide**

The infamous “rotten egg” odor, **hydrogen sulfide** (H_2S) can contribute to corrosion. It is found primarily in well water supplies or other anaerobic sources. H_2S can be readily oxidized by chlorine or ozone to eliminate sulfur.

- **Radon**

Radon is a water-soluble gas produced by the decay of radium and its isotopes. It is the heaviest gas known and occurs naturally in groundwater from contact with granite formations, phosphate and uranium deposits. Prolonged exposure may cause human health problems including cancer.

Heavy Metals

Heavy metals such as lead, arsenic, cadmium, selenium and

chromium – when present above certain levels – can have harmful effects on human health. In addition, minute concentrations may interfere with the manufacture and effectiveness of pharmaceutical products, as well as laboratory and industrial processes of a sensitive nature.

Dissolved Organic Compounds

Dissolved organic materials occur in water both as the product of material decomposition and as pollution from synthetic compounds such as pesticides.

• Naturally-Occurring

Tannins, **humic acid** and fulvic acids are common natural contaminants. They cause color in the water and detract from the aesthetics of water but, unless they react with certain halogens, they have no known health consequences in normal concentrations. In the presence of free halogen compounds (principally chlorine or bromine), they form chlorinated **hydrocarbons** and trihalomethanes (THM's), which are suspected carcinogens. Maximum allowable limits of THM's in municipal systems have been imposed by the United States Environmental Protection Agency (**EPA**).

• Synthetic Organic Compounds (SOC's)

A wide variety of synthetic compounds which are potential health hazards are present in water systems due to the use of industrial and agricultural chemicals. These compounds are not readily biodegradable and leach from soil or are carried by runoff into water sources. Many are suspected carcinogens and are regulated by the EPA.

Volatile Organic Compounds (VOC)

Due to relatively low molecular weight, many synthetic organic compounds such as carbon tetrachloride, chloroform and methylene chloride will easily volatilize. Volatility is the tendency of a compound to pass into the vapor state. Most are introduced into the water supply in their liquid **phase**. If ingested they may be absorbed into the bloodstream. Many are suspected carcinogens.

Radioactive Constituents

Water in itself is not radioactive but may contain radionuclides. They are introduced either as naturally-occurring isotopes (very rare) or refined nuclear products from industrial or medical processes, radioactive fallout or nuclear power plants.

4.0 METHODS OF WATER PURIFICATION

Water treatment can be defined as any procedure or method used to alter the composition or “behavior” of a water supply. Water supplies are classified as either surface water or groundwater. This classification often determines the condition and therefore the treatment of the water. The majority of public or municipal water comes from surface water such as rivers, lakes and reservoirs. The majority of private water supplies consist of groundwater pumped from wells.

4.1 Municipal or Utility Water Treatment

Most municipal water distributed in a city or community today has been treated extensively. Specific water treatment methods and steps taken by municipalities to meet local, state or national standards vary, but are categorized below.

Screen Prefiltration

A coarse screen, usually 50 to 100 mesh (305 to 140 microns), at the intake point of a surface water supply, removes large particulate matter to protect downstream equipment from clogging, **fouling**, or physical damage.

Clarification

Clarification (Figure 6) is generally a multistep process to reduce turbidity and remove suspended matter. First, the addition of chemical **coagulants** or pH-adjustment chemicals react to form **floc**. The floc settles by gravity in settling tanks or is removed as the water percolates through a gravity filter. The clarification process effectively removes particles larger than 25 microns. Clarification steps may also be taken to reduce naturally-occurring iron, and to remove colors, taste, and odor by adding strong oxidizing agents such as chlorine. Where gravity filters are used, activated carbon slurries are sometimes added to aid in color and odor removal.

Clarification can remove a high percentage of suspended solids at a relatively low cost per gallon. However, most clarification processes will not remove all types of suspended or colloidal contamination and remove few **dissolved solids**. The clarification process is not 100% efficient; therefore, water treated through clarification may still contain some suspended materials.

Lime-Soda Ash Treatment

The addition of lime (CaO) and soda ash (Na_2CO_3) reduces the level of calcium and magnesium and is referred to as “lime softening.” The purpose of lime softening is to precipitate calcium and magnesium hydroxides (hardness) and to help clarify the water. The process is inexpensive but only marginally effective, usually producing water of 50 to 120 ppm (3 to 7 gpg) hardness. A short-coming of this process is the high pH of the treated water, usually in the 8.5 to 10.0 range. Unless the pH is buffered to approximately 7.5 to 8.0, the condition of the water is usually unacceptable for general process use.

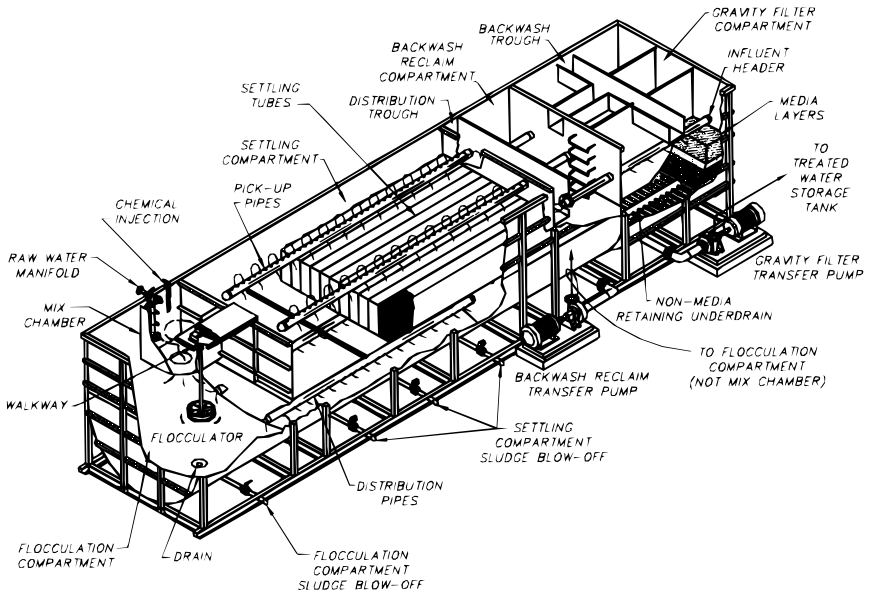

Figure 6 – Clarifier

Disinfection

Disinfection is one of the most important steps in municipal water treatment. Usually chlorine gas is fed into the supply after the water has been clarified and/or softened. The chlorine kills bacteria. In order to maintain the “kill potential” an excess of chlorine is fed into the supply to maintain a residual. The chlorine level at outlying

distribution points is usually monitored at a target level of about 0.2 to 0.5 ppm. However, if the water supply is heavily contaminated with organics, the chlorine may react to form chloramines and certain chlorinated hydrocarbons (THM's), many of which are considered carcinogenic. In other cases the chlorine can dissipate and no residual level is maintained at the point-of-use, allowing microbial growth to occur. To prevent this problem, some municipalities add ammonia or other nitrogen compounds to create chloramines. The NH_2Cl compounds formed have a much longer half-life, allowing a measurable chlorine residual to be maintained to extreme points-of-use. The residual chloramines may pose their own problems.

pH Adjustment

Municipal waters may be pH-adjusted to approximately 7.5 to 8.0 to prevent corrosion of water pipes and fixtures, particularly to prevent dissolution of lead into a potable water supply. In the case of excessive alkalinity, the pH may be reduced by the addition of acid. The alkalinity will convert to CO_2 .

4.2 On-Site Treatment

After the water is delivered from the utility or the well, there are many on-site options for further treatment to meet specific end-use requirements.

Chemical Addition

• pH Adjustment

Certain chemicals, **membranes**, ion exchange **resins** and other materials are sensitive to specific pH conditions. For example, prevention of acid corrosion in boiler feedwater typically requires pH adjustment in the range of 8.3 to 9.0.

To raise pH, soda ash or **caustic soda** may be inexpensively added. However, both cause handling difficulties, require fine-tuning, and add to the TDS.

To reduce pH, a buffering solution such as sulfuric acid (H_2SO_4) is added into the flow with a chemically-resistant pump (Figure 7).



Figure 7 – Chemically-Resistant Pumps

- **Dispersants**

Dispersants, also known as antiscalants, are added when scaling may be expected due to the concentration of specific ions in the stream exceeding their solubility limit. Dispersants disrupt crystal formation, thereby preventing their growth and subsequent precipitation.

- **Sequestering (Chelating) Agents**

Sequestering agents are used to prevent the negative effects of hardness caused by the deposition of Ca, Mg, Fe, Mn and Al.

- **Oxidizing Agents**

Oxidizing agents have two distinct functions: as a biocide, or to neutralize reducing agents. For information on biocides, see the section on disinfection.

- **Potassium Permanganate**

Potassium permanganate (KMnO_4) is a strong oxidizing agent used in many bleaching applications. It will oxidize most organic compounds and is often used to oxidize iron from the ferrous to the ferric form for ferric precipitation and filtration.

- **Reducing Agents**

Reducing agents, like sodium metabisulfite ($\text{Na}_2\text{S}_2\text{O}_5$), are added to neutralize oxidizing agents such as chlorine or **ozone**. In membrane and ion exchange systems, reducing agents help prevent the degradation of membranes or resins sensitive to oxidizing agents. Reducing agents are metered into solution and allowed enough residence time for chemical neutralization. Maintenance of a residual continues to eliminate the oxidizing agent.

Tank-Type Pressure Filters

There are several types of so-called pressure filters available, each performing a specialized task. A single description of the equipment mechanics is sufficient to understand the principal.

A typical filter consists of a tank, the filter media, and valves or a controller to direct the filter through its various cycles – typically service, **backwash** and rinse.

Easily the most critical aspect of pressure filter performance is the relationship of flow rates to filter bed area and bed depth. This relationship is the primary cause of trouble and poor performance in filter systems. If problems develop, the most common reason is that

many filters are inaccurately “sized” for the job. The **nominal** flow rate in the service cycle depends on bed area available and generally should not exceed a nominal rate of 5 gallons (18.8 L) per minute (gpm) per square foot of bed area (12.15 m³/h per m²), with at least a 30-inch (76.2 cm) filter bed depth.

Another important design criterion is backwash flow rate. Backwash flow rates are a function of backwash water temperature, type, size, and density of media, and the specific design of the pressure filter. Media with densities of 90-100 lb/ft³ generally require 12 to 16 gpm/ft² of bed area. Less dense media may use lower backwash rates. Very cold water uses somewhat lower backwash rates, and warmer water requires higher rates. The table below expresses this relationship as a function of tank diameter. There are many types of filter media but all of them should follow the flow rate guidelines in Table 6.

Table 6 – Pressure Filter Size Chart

Tank Diameter inch (mm)	Bed Area ft ² (cm ²)	Maximum Service Flow gpm (m ³ /h)	Minimum Backwash Flow gpm (m ³ /h)
8 (203)	0.35 (325)	1.7 (0.4)	2.8 (0.6)
10 (254)	0.55 (511)	2.7 (0.6)	4.4 (1.0)
13 (330)	0.92 (855)	4.6 (1.0)	7.4 (1.7)
16 (406)	1.4 (1301)	7.0 (1.6)	11.2 (2.5)
20 (508)	2.2 (2044)	10.9 (2.5)	17.6 (4.0)
30 (762)	4.9 (4552)	24.5 (5.6)	39.2 (8.9)
42 (1067)	9.6 (8918)	48.0 (10.9)	76.8 (17.4)

NOTE: Minimum backwash flow rates may be higher for some dense media or warmer water [over 77°F (25°C)].

Some examples of pressure filters and their applications are:

• **Sand Filters**

Sand is one **filtration** medium used to remove turbidity. Sand filters can economically process large volumes, but have two limitations. The finer sand medium is located on top of coarser support media, which causes the filter to plug quickly and requires frequent backwashing. Also, the coarseness of sand media allows smaller suspended solids to pass, so secondary filters with tighter media are often required.

- **Neutralizing Filters**

Neutralizing filters usually consist of a calcium carbonate, calcite medium (crushed marble) to neutralize the acidity in low pH water.

- **Oxidizing Filters**

Oxidizing filters use a medium treated with oxides of manganese as a source of oxygen to oxidize a number of contaminants including iron, manganese and hydrogen sulfide. The oxidized contaminants form a precipitate that is captured by the particle filtration capacity of the medium.

- **Activated Carbon Filters**

Activated carbon (AC) is similar to ion exchange resin in density and porosity. It adsorbs many dissolved organics and eliminates chlorine or other halogens in water. It does not remove salts. AC filters are one of the only low-cost methods available to remove low-molecular weight (<100 MW) organics and chlorine.

AC filters may become a breeding site for bacteria and pyrogenic materials. The carbon must be sanitized or changed periodically to avoid bacterial growth, and when all adsorption sites are used it must be reactivated by a controlled heat process. This is not easily reactivated in the field. The suspended solids accumulated in the bed from most water sources require frequent backwashing of the filter unless installed after reverse osmosis or ultrafiltration.

- **Dual- or Multi-Media Filters**

Progressively finer layers of filter media trap increasingly smaller particles. The arrangement of the media (coarse and less dense on top of finer higher density placed deeper in the bed) enables the filter to run for longer periods of time before backwashing is necessary. Dual-media filters remove suspended solids to as low as 10-20 microns in size, but no dissolved solids. The top layer is a typically coarse anthracite followed by fine sand.

Pre-Coat Filters

Pre-coat filters use a filter aid medium, usually a diatomaceous earth (DE) slurry which is put on a coarser support medium and used (Figure 8) to remove very small particulate matter. DE filters can remove particles down to 5 microns and below, including some removal of protozoa and even bacteria. The medium must be changed frequently and presents a waste disposal problem. Pre-coat filters are most practical for limited volume applications and are

common for swimming pools, beverage plants, and certain industrial applications.

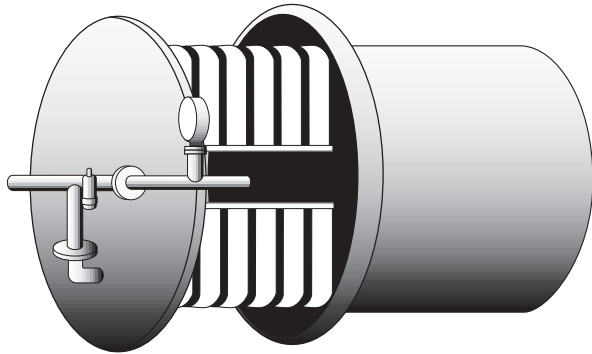

Figure 8 – Pre-Coat Filter

Cartridge Filters

Cartridge filters were once considered only as a point-of-use water treatment method for removal of larger particles. However, breakthroughs in filter design, such as the controlled use of blown microfiber filters (as opposed to wrapped fabric or yarn-wound filters), have tremendously broadened cartridge filter utilization. Cartridge filters fall into two categories: depth filters or surface filters.

• Depth Cartridge Filters

In a depth cartridge filter the water flows through the thick wall of the filter where the particles are trapped throughout the complex openings in the medium. The filter may be constructed of cotton, cellulose and synthetic yarns, chopped fibers bound by adhesives, or “blown” microfibers of polymers such as polypropylene.

The most important factor in determining the effectiveness of depth filters is the design of the porosity throughout the thick wall. The best depth filters for many applications have lower density on the outside and progressively higher density toward the inside wall. The effect of this “graded density” (Figure 9) is to trap coarser particles toward the outside of the wall and the finer particles toward the inner wall. Graded-density filters have a higher dirt-holding capacity and longer effective filter life than depth filters with constant density construction.

METHODS OF WATER PURIFICATION

Disposal of spent cartridges is an environmental concern; however, some cartridges have the advantage of being easily incinerated.

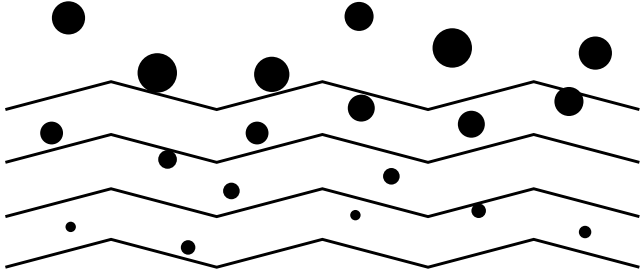

Figure 9 – Depth vs. Surface Media

METHODS OF WATER PURIFICATION

Depth cartridge filters (Figure 10) are usually disposable and cost-effective, and are available in the particle-removal size range of 0.5 to 100 microns. Generally, they are not an **absolute** method of filtration since a small amount of particles within the micron range may pass into the **filtrate**. However, there are an increasing number of depth filters in the marketplace that feature near-absolute retention ratings.



Figure 10 – Microfiber Depth Cartridge Filters

• Surface Filtration – Pleated Cartridge Filters

Pleated cartridge filters (Figure 11) typically act as surface filters. Flat sheet media, either membranes or nonwoven fabric materials, trap particles on the surface. The media are pleated to increase usable surface area. Pleated filters are usually not cost-effective for water filtration, where particles greater than one micron quickly plug them. However, pleated membrane filters serve well as submicron particle or bacteria filters in the 0.1- to 1.0-micron range and are often used to polish water after depth filters and other treatment steps in critical applications. Pleated filters are usually disposable by incineration, since they are constructed with polymeric materials, including the membrane. Newer cartridges also perform in the ultrafiltration range: 0.005- to 0.15-micron.



Figure 11 – Pleated Filters (Surface Filtration)

• Ultrafiltration (UF) Cartridge Filters

UF membrane cartridges (Figure 12) perform much finer filtration than depth filters but are more expensive and require replacement as the filter becomes “**blinded**,” i.e., covered with an impervious thin coating of solids. Typically, the smaller the pore the more quickly this blinding occurs. To avoid blinding of the **pores**, point-of-use ultrafiltration cartridges are built in a spiral-wound configuration to allow crossflow mode operation to help keep the surface clean by rinsing away the solids.

Point-of-use ultrafiltration cartridges are used to remove colloids, pyrogens and other macromolecular compounds from ultrapure water.



Figure 12 – Point-of-Use System

Ion Exchange Systems

An ion exchange system consists of a tank containing small beads of synthetic resin (Figure 13). The beads are treated to selectively adsorb either cations or anions and release (exchange) “counter-ions” based on the relative activity compared to the resin. This process of ion exchange will continue until all available exchange sites are filled, at which point the resin is exhausted and must be regenerated by suitable chemicals.

Ion exchange systems are used in several ways.

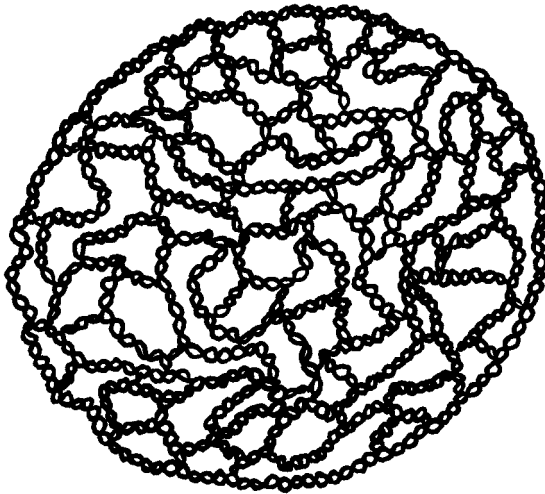

Figure 13 – Representation of Ion Exchange Resin Bead

• Water Softening

The ion exchange water softener (Figure 14) is one of the most common tools of water treatment. Its function is to remove scale-forming calcium and magnesium ions from hard water. In many cases soluble iron (ferrous) can also be removed with softeners. A standard water softener has four major components: a resin tank, resin, a brine tank to hold sodium chloride, and a valve or controller.



Figure 14 – Duplex Water Softening Resin Tanks

The softener resin tank contains the treated ion exchange resin – small beads of polystyrene. The resin bead exchange sites adsorb sodium ions and displace multivalent cations during **regeneration** with 6-10% solution of NaCl. The resin has a greater affinity for multivalent ions such as calcium and magnesium than it does for sodium. Thus, when hard water is passed through the resin tank in service, calcium and magnesium ions adhere to the resin, releasing the sodium ions until equilibrium is reached.

When most of the sodium ions have been replaced by hardness ions, the resin is exhausted and must be regenerated. Regeneration is achieved by passing a concentrated NaCl solution through the resin tanks, replacing the hardness ions with sodium ions. The resin's

affinity for the hardness ions is overcome by the concentrated NaCl solution. The regeneration process can be repeated indefinitely without damaging the resin.

Water softening is a simple, well-documented ion exchange process. It solves a very common form of water contamination: hardness. Regeneration with sodium chloride is a simple, inexpensive process and can be automatic, with no strong chemicals required.

The limitations of water softening become apparent when high-quality water is required. Softening merely exchanges the hardness ions for normally less-troublesome sodium ions which are still unsuitable for many uses.

• Deionization (DI)

Ion exchange deionizers use synthetic resins (Figure 15) similar to those in water softeners. Typically used on water that has been prefiltered, DI uses a two-stage process to remove virtually all ionic material in water. Two types of synthetic resins are used: one to exchange positively-charged ions (**cations**) for H^+ and another to exchange negatively-charged ions (**anions**) for OH^- .

Cation **deionization** resins (hydrogen cycle) release hydrogen (H^+) in exchange for cations such as calcium, magnesium and sodium. Anion deionization resins (hydroxide cycle) exchange hydroxide (OH^-) ions for anions such as chloride, sulfate and bicarbonate. The displaced H^+ and OH^- combine to form H_2O .



Figure 15 – Ion-Exchange Resin

Resins have limited capacities and must be regenerated upon **exhaustion**. This occurs when equilibrium between the adsorbed ions is reached. Cation resins are regenerated by treatment with acid which replenishes the adsorption sites with H^+ ions. Anion resins are regenerated with a base which replenishes the resin with (OH^-) ions. Regeneration can take place off-site with exhausted resin exchanged with deionizers (Figure 16) brought in by a service company. Regeneration can also be accomplished on-site by installing regenerable-design deionizer equipment and by proper use of the necessary chemicals.



Figure 16 – Exchange Tank Deionizer

- **Two-Bed and Mixed-Bed Deionizers**

The two basic configurations of deionizers are **two-bed** and **mixed-bed**.

Two-bed deionizers (Figure 17) have separate tanks of cation and anion resins. In mixed-bed deionizers (Figure 18) the two resins are blended together in a single tank or vessel. Generally mixed-bed systems will produce higher-quality water, but with a lower total capacity than two-bed systems.



Figure 17 – Two-Bed Deionizer



Figure 18 – Mixed-Bed Deionizer

Deionization can produce extremely high-quality water in terms of dissolved ions or minerals, up to the maximum purity of 18.3 megohms/cm resistance. However, it generally cannot remove organics, and can become a breeding ground for bacteria actually diminishing water quality if organic and microbial contamination are critical.

Failure to regenerate the resin at the proper time may result in salts remaining in the water or even worse, being increased in concentration. Even partially-exhausted resin beds can increase levels of some contaminants due to varying selectivity for ions, and may add particulates and resin fines to the deionized water.

Organic Scavenging

Organic scavengers, or traps, contain strong-base anion resin since most naturally-occurring organics have a slightly negative charge. After the resin is loaded the organics can be displaced by the Cl^- anion during regeneration with high concentrations of sodium chloride brine.

Distillation and Pure Steam Generators

Distillation (Figure 19) is the collection of condensed steam produced by boiling water. Most contaminants do not **vaporize** and, therefore, do not pass to the condensate (also called **distillate**).

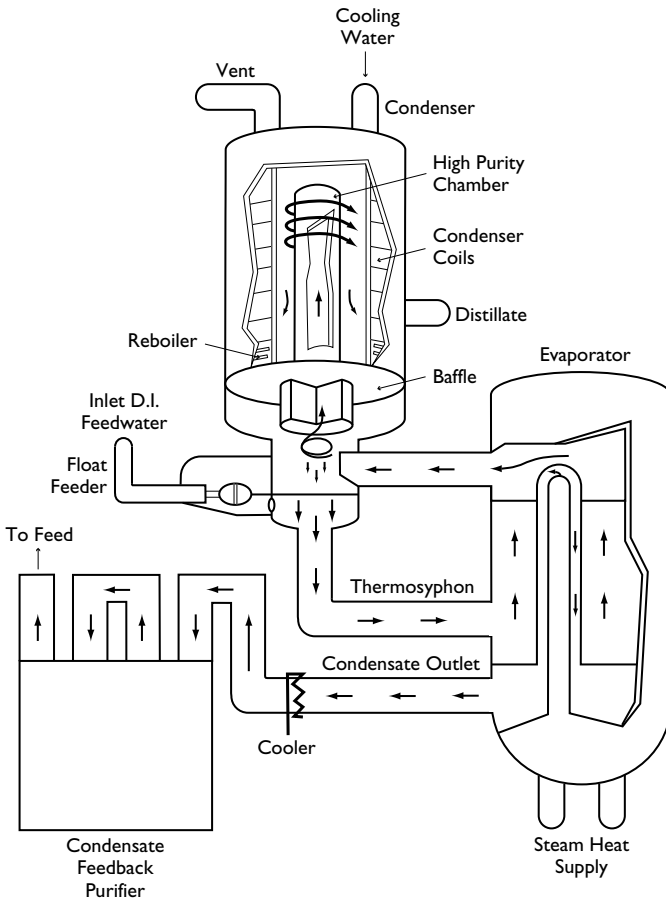

Figure 19 – Distillation Process / Single-Effect Still Schematic

With a properly-designed still, removal of both organic and inorganic contaminants, including biological impurities such as pyrogens, is attained. Since distillation involves a phase change, when properly carried out by a correctly designed and operated still, it removes all impurities down to the range of 10 parts per trillion (**ppt**), producing water of extremely high purity. Close control over boiling temperature and boiling rate, as well as the separation of steam from potential carryover, is required for the purest water.

Distillation is comparatively energy-intensive. However, the development of **multiple-effect distillation** (Figure 20a) has dramatically reduced the energy consumption required versus single-effect units (Figure 20b). Higher temperature steam is used repeatedly, losing some heat in each stage (effect) but substantially reducing overall energy use.

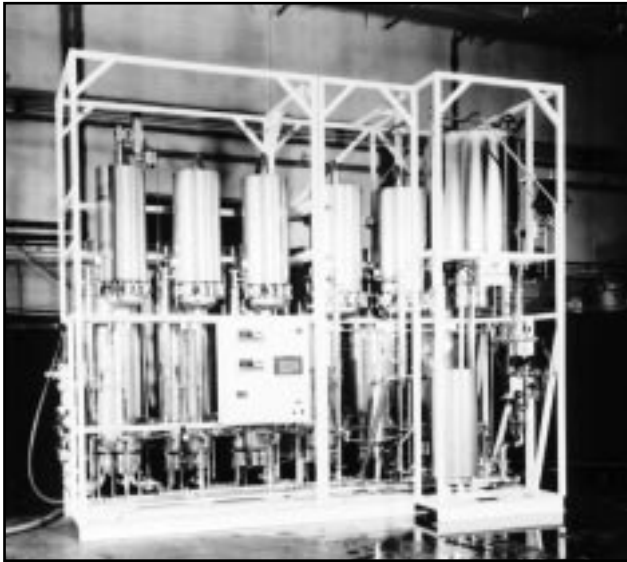

Figure 20a – Multiple-Effect WFI Still



Figure 20b – Single-Effect Still

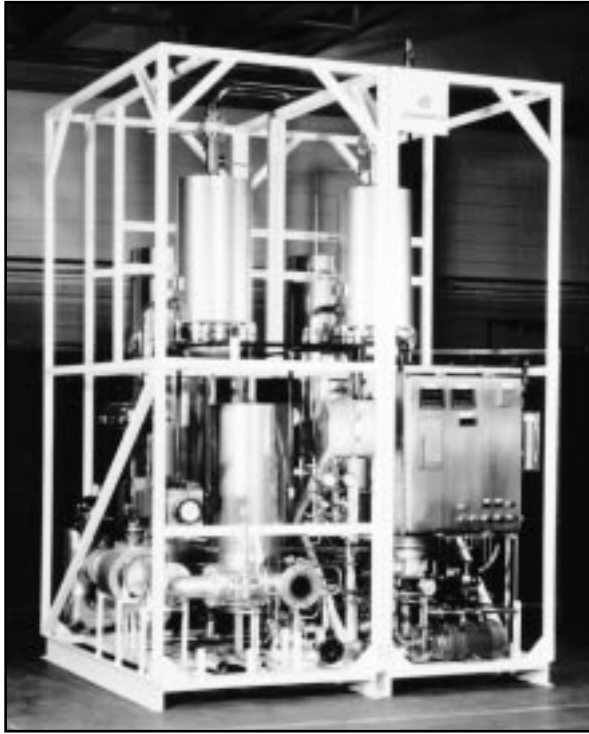

Figure 20c – Pure Steam Generator

Today the most significant use of stills is in laboratories and the biotechnology and pharmaceutical industries because of their critical concern for biological contamination. Distillation is the most accepted technology for a consistent supply of pyrogen-free water without the use of chemical additives. Careful temperature monitoring is required to ensure purity and avoid recontamination of the purified water.

Membrane technologies such as reverse osmosis (RO) and ultrafiltration (UF) are increasingly used as pretreatment to distillation to reduce maintenance caused by scaling and organic contamination, and to increase distillate quality. In most cases the RO system removes most organics, bacteria and pyrogens, and the majority of the salts. The still acts as a backup system for absolute microbe and other contaminant removal in assuring consistent USP WFI-quality (pharmaceutical) water (see Section 5.4). Some combinations of the technologies are unique enough to earn patent protection.

Electrodialysis

Electrodialysis (ED) and electro dialysis reversal (EDR) (Figure 21) employ electrical current and specially-prepared membranes which are **semipermeable** to ions based on their charge, electrical current, and ability to reduce the ionic content of water. Two flat sheet membranes, one that preferentially **permeates** cations and the other, anions, are stacked alternately with flow channels between them. Cathode and anode electrodes are placed on each side of the alternating stack of membranes to draw the “counter” ions through the membranes, leaving lower concentrations of ions in the feedwater.

The efficiency of electro dialysis depends on the ionic solids and fouling potential from organics and particles in the feedwater, the temperature, the flow rate, system size and required electrical current. Organics and weakly-charged inorganics are not removed by ED. Recent developments have improved the efficiency of ED by reversing the polarity of the electrodes periodically. This is called EDR and has reduced the scaling and **fouling** problems common to ED.

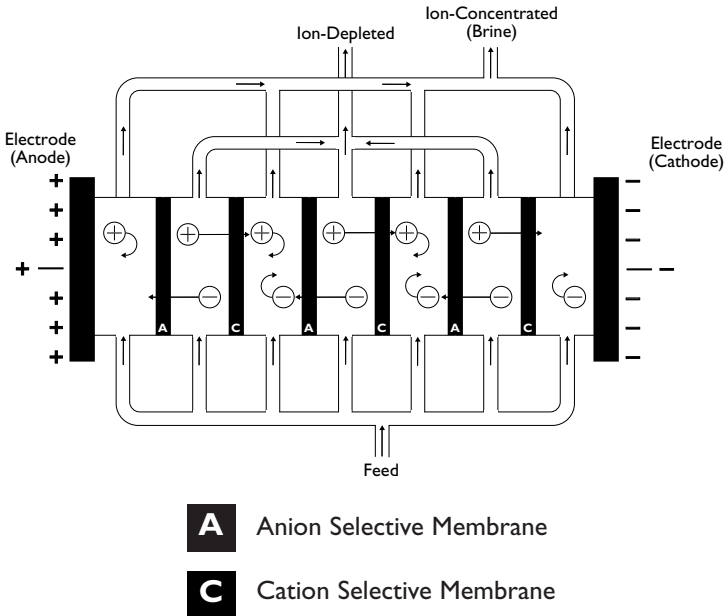

Figure 21 – Electro dialysis Reversal (EDR) System

Crossflow Filtration Systems (Reverse Osmosis and Similar Processes)

Reverse osmosis, invented in 1959, is the newest major method of water purification and one of the types of **crossflow membrane filtration**. It is a process which removes both dissolved organics and salts using a mechanism different from ion exchange or activated carbon. The pressurized feedwater flows across a membrane, with a portion of the feed permeating the membrane. The balance of the feed sweeps parallel to the surface of the membrane to exit the system without being filtered. The filtered stream is the “**permeate**” because it has permeated the membrane. The second stream is the “**concentrate**” because it carries off the concentrated contaminants rejected by the membrane (Figure 22). Because the feed and concentrate flow parallel to the membrane instead of perpendicular to it, the process is called “crossflow filtration” (or, erroneously, “tangential flow”).

Depending on the size of the pores engineered into the membrane, crossflow filters are effective in the classes of separation known as reverse osmosis, nanofiltration, ultrafiltration and the more recent **microfiltration**. The Filtration Spectrum (Figure 23) shows the relationship among the pore sizes and contaminants removed during each process.

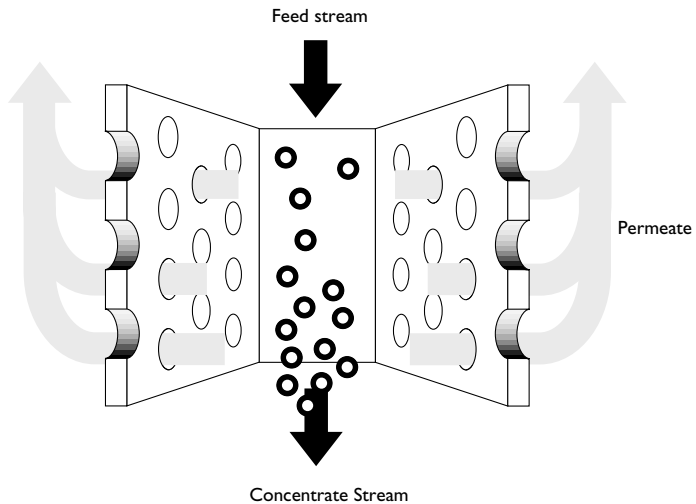
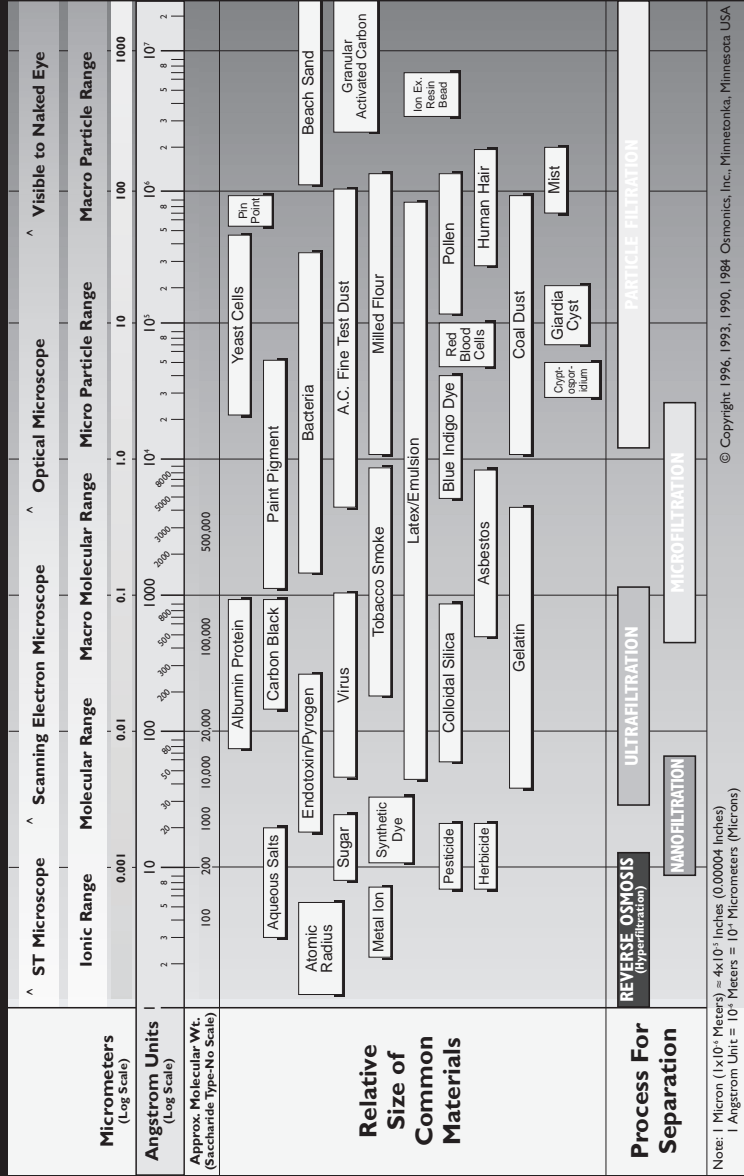

Figure 22 – Crossflow Filtration

OSMONICS *The Filtration Spectrum*



© Copyright 1996, 1993, 1990, 1984 Osmonics, Inc., Minnetonka, Minnesota, USA

Osmonics, Inc.
 Corporate Headquarters
 5951 Clearwater Drive • Minnetonka, Minnesota 55343-8990 USA
Toll Free: 800/848-1750 Fax: 612/933-0141

Osmonics Asia/Pacific, Ltd.
 Bangkok/Thailand
 Tokyo, Japan

Osmonics Europe, S.A.
 LaMee Sur Seine (Paris), France
Fax: 011-331-64-37-9211

Figure 23 – Filtration Spectrum

Crossflow membrane filtration allows continuous removal of contaminants which in “normal flow” filtration would “blind” (cover up) or plug the membrane pores very rapidly. *Thus the crossflow mode of operation is essential to these processes.*

- **Reverse Osmosis (RO)**

Reverse osmosis (RO) was the first crossflow membrane separation process to be widely commercialized. RO removes most organic compounds and up to 99% of all ions (Figure 24). A selection of RO membranes is available to address varying water conditions and requirements.

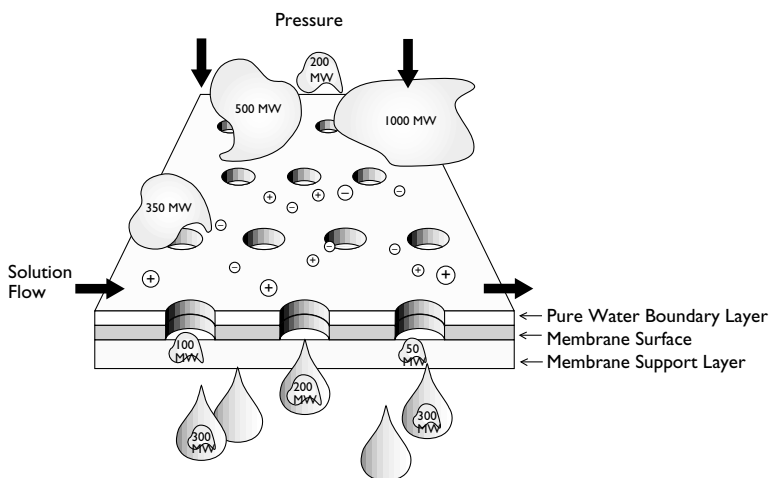

Figure 24 – Reverse Osmosis

RO can meet most water standards with a single-pass system and the highest standards with a double-pass system. This process achieves **rejections** of 99.9+% of **viruses**, bacteria and pyrogens. Pressure in the range of 50 to 1000 **psig** (3.4 to 69 bar) is the driving force of the RO purification process. It is much more energy-efficient compared to phase change processes (distillation) and more efficient than the strong chemicals required for ion exchange regeneration.

METHODS OF WATER PURIFICATION

- **Nanofiltration (NF)**

Nanofiltration (NF) equipment removes organic compounds in the 250 to 1000 molecular weight range, also rejecting some salts (typically divalent), and passing more water at lower driving pressures than RO (Figure 25). NF economically softens water without the pollution of regenerated systems and provides unique fractionation capabilities such as organics desalting.

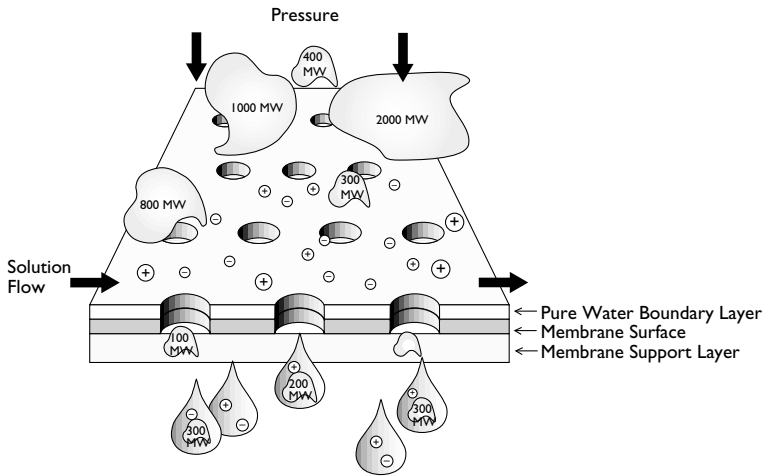

Figure 25 – Nanofiltration

• Ultrafiltration (UF)

Ultrafiltration (UF) is similar to RO and NF, but is defined as a crossflow process that does not reject ions (Figure 26). UF rejects solutes above 1000 daltons (molecular weight). Because of the larger pore size in the membrane, UF requires a much lower differential operating pressure: 10 to 100 psig (0.7 to 6.9 bar). UF removes larger organics, colloids, bacteria, and pyrogens while allowing most ions and small organics such as sucrose to permeate the porous structure.

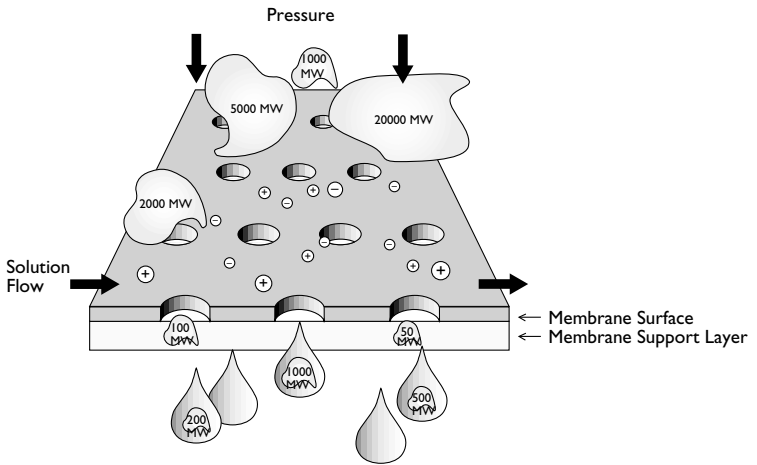

Figure 26 – Ultrafiltration

METHODS OF WATER PURIFICATION

- **Microfiltration (MF)**

Microfiltration (MF) membranes are absolute filters typically rated in the 0.1- to 3.0-micron range. Available in polymer, metal and ceramic membrane discs or pleated cartridge filters, MF is now also available in crossflow configurations (Figure 27). Operating differential pressures of 5 to 25 psig (0.3 to 1.7 bar) are typical.

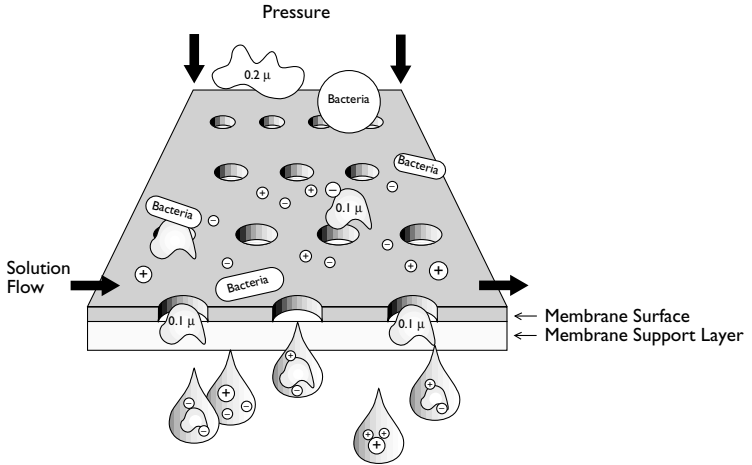

Figure 27 – Microfiltration

Crossflow MF substantially reduces the frequency of filter media replacement required compared to **normal flow** MF because of the continuous self-cleaning feature. Crossflow MF systems typically have a higher capital cost than MF cartridge filter systems; however, operating costs are substantially lower.

Membrane Configurations

Crossflow membranes are manufactured into various configurations – tubular, hollow-fiber, flat-sheet or spiral-wound. Due to relative efficiency and economy, spiral-wound membrane elements (called **sepralators**) are by far the most popular for crossflow water purification.

• Sepralators (Spiral-Wound Membrane Elements)

Sepralators have gained the greatest acceptance in the market. They are the most rugged, leak-free and pressure-resistant configuration. The spiral design allows for optimum membrane surface area and fluid dynamics to produce a high permeate flow for the size of equipment required. Sepralators are available with RO, NF, UF, and MF membranes. Sepralators (Figure 28) are quite easy to maintain with a routine cleaning program. A major advantage is enhanced “self-cleaning” due to turbulent flow at the membrane surface. This feature dramatically reduces fouling, thereby enhancing performance and membrane life. Spiral-wound designs also offer the greatest selection of membrane material, allowing users to “tailor” a system design to suit their purification requirements.

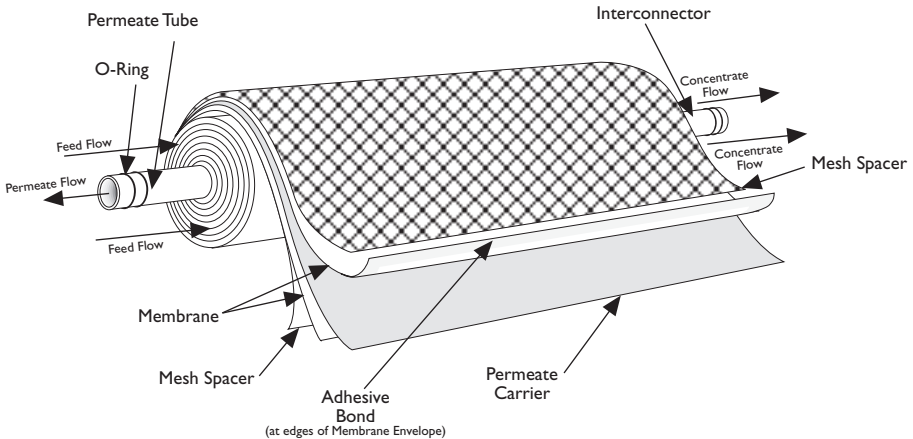

Figure 28 – Spiral-Wound Membrane Element (Sepralator)

• Hollow Fine-Fiber Elements

Hollow fine-fiber elements (Figure 29) consist of hollow fibers each roughly the size of a human hair. Thousands of fibers are closely bundled in each housing. The pressurized feed flows slowly over the outside of the fibers and pure water permeates to the center. Then

the water is collected out of potted tube sheet.

In the early 1970's hollow fine-fiber water purification systems gained popularity because of their high productivity resulting from very high membrane surface areas. The major disadvantage of this element is the amount of prefiltration required to keep the tightly-packed membrane surface free of severe fouling due to the **laminar flow** in the element.

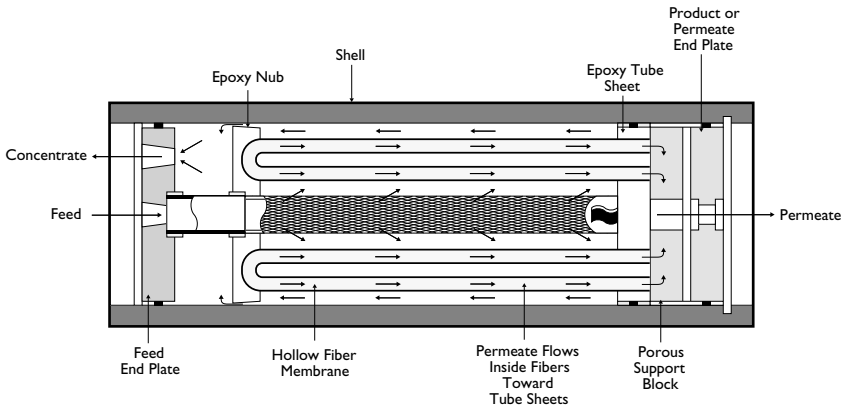

Figure 29 – Hollow Fine-Fiber Permeator (Membrane Element)

• Hollow Fat-Fiber Elements

Hollow fat-fiber elements (Figure 30) are only used in UF and MF due to burst-strength limitations. The pressurized feed flow is on the inside of the fiber and water permeates to the outside of the fiber. The fibers are potted at each end in a housing. Their self-supporting nature limits maximum feed flows. **70 psid (4.8 bar)** is the pressure limit through elements constructed with these small fibers.

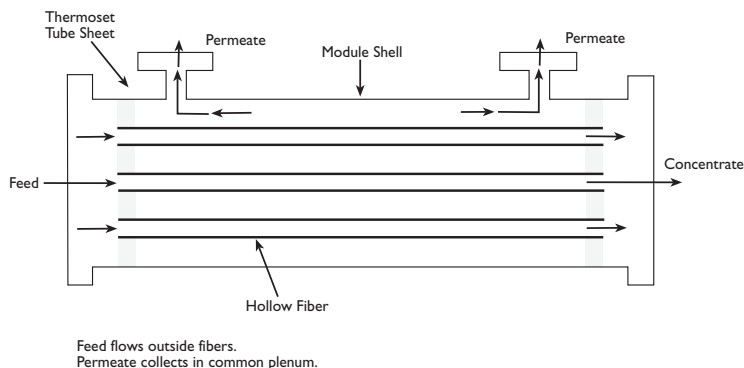

Figure 30 – Hollow Fiber Element

Disinfection – Control of Microbes

Control of microorganism populations is essential in maintaining the performance of any water system. An example is in ultrapure water systems in which bacterial fouling is a leading cause of contamination, and carefully monitored bacterial control is a necessity.

Biological control of a water system is accomplished by maintaining a continuous biocide residual throughout the system, or by sanitizing the system on a regular basis. A continuous biocide residual is preferable because it keeps bacterial growth in check and prevents “biofilms.” However, in some high-purity water systems this is not possible, so regular sanitizations are needed. In either case, one of the most effective control measures is to keep the system running continuously, since bacteria reproduce more quickly during shut-down. If this is not possible, a 15- to 30-minute flush every four hours is helpful.

Two important considerations when using a biocide are concentration and contact time. The higher the concentration, the shorter the contact time needed for effective disinfection. Other factors which affect biocide activity are pH, temperature, water hardness, establishment of a biofilm and general cleanliness of equipment.

In many cases, the system needs to be cleaned before it is disinfected. Cleaning helps to remove bacterial film and dirt that can mask bacteria and viruses in the equipment. The film would allow only the surface bacteria to be killed, and the bacteria would quickly re-establish themselves.

- **Chemical**

- **Oxidizing Biocides**

- Chlorine

By far the most commonly-used biocide because of its low cost and high effectiveness, chlorine is well understood, accepted and readily available. Chlorine is most effective below pH 7. The major disadvantage is safety of handling, particularly for large systems which use chlorine gas.

Chlorine is dosed continually to maintain residuals of 0.2 to 2 ppm. Periodic sanitation “shock treatments” are accomplished with 100-200 ppm concentrations for 30 minutes. Care must be taken to ensure that materials of construction including membranes, filters and other items are compatible and will not be damaged.

- Chlorine Gas

Chlorine gas is the most cost-effective form of chlorine addition for systems over 200 gpm (757 Lpm). A special room for chlorine storage and **injection** is required along with substantial safety procedures.

For smaller systems, chlorine is used in forms including sodium hypochlorite (NaOCl) and calcium hypochlorite dihydrate $[\text{Ca}(\text{OCL})_2 \cdot 2\text{H}_2\text{O}]$ liquids. Both are available at varying concentrations.

- Chloramines

Chloramines are produced by reacting chlorine with ammonia. Chloramines are much more stable compared to chlorine and are used in some municipalities to ensure a residual will be available at the end of the distribution system. The disadvantage over chlorine is the longer contact time required by chloramines for disinfection.

- Chlorine Dioxide

Chlorine dioxide (ClO_2) is an effective form of chlorine but because it is more expensive, its use is limited. It is more effective at high pH and more compatible with some membranes than chlorine. Another advantage is stability in storage at concentrations used for smaller systems. It can degrade aromatic compounds such as humic and folic acids from surface water sources. It is somewhat corrosive and must be handled with care.

– Ozone

Ozone is twice as powerful an oxidant as chlorine. **Ozone (O_3)** is manufactured onsite by discharging an electric current through air (Figures 31a & 31b). The oxygen (O_2) in the air forms O_3 which is highly reactive and unstable. Ozone does not add any ionic contamination because it degrades to O_2 . Ozone must be dosed into water on a continuous basis because it has a very short half-life (approximately 20 minutes at ambient temperatures) in solution. In certain applications all ozone must be removed prior to end use. This may be achieved by exposing the ozonated water to **ultraviolet** light which breaks down the ozone to oxygen.



Figure 31a – Ozone Generator



Figure 31b – Ozone Generator

– Hydrogen Peroxide

An effective disinfectant, hydrogen peroxide (H_2O_2) does not add contaminant ions to water because it degrades into H_2O and O_2 . This is an advantage in critical systems such as microelectronics where low-level ionic contamination is a concern. Hydrogen peroxide can also be used on membranes that cannot tolerate chlorine.

Hydrogen peroxide generally requires high concentrations to be effective and must be catalyzed by iron or copper, which are not present in ultrapure water systems. Without a catalyst, up to a 10% (by volume) solution may be required, which is less practical.

– Bromine

As a halogen, bromine (Br_2) is similar to chlorine in its actions although the cost of bromine is greater. Bromine is used on a limited basis, most often for the disinfection of indoor swimming pools and spas. It maintains a residual in warm water better than chlorine, but degrades rapidly in sunlight from the ultraviolet part of the spectrum.

– Iodine

Commonly used by campers and the military for microbial treatment for potable water in the field, iodine (I_2) is not recommended on a

continuous basis for potable water because of its potential ill effects on human thyroid metabolism. It can be used at low concentrations (0.2 ppm) to control bacteria in RO water storage systems; however, it is approximately three times more expensive than chlorine and will stain at higher concentrations.

– Peracetic Acid

A relatively new disinfectant, peracetic acid (CH_3COOOH) exists in equilibrium with hydrogen peroxide and is used mainly in dialysis equipment disinfection as a replacement for formaldehyde. It is claimed to have effectiveness similar to formaldehyde, but without the handling difficulties. Also, it is compatible with some membranes which are not chlorine-tolerant, and is a small enough **molecule** to pass through the membrane and disinfect the downstream side. It breaks down to non-hazardous acetic acid and water. Its disadvantages are high cost, toxicity in concentrated doses, instability, lack of historical effectiveness, and compatibility with materials of construction.

Nonoxidizing Biocides

– Formaldehyde (HCHO)

Formaldehyde has been a commonly-used disinfectant because of its stability, effectiveness against a wide range of bacteria, and low corrosiveness. As a sporicide, formaldehyde can be classed as a sterilizing agent. It is being phased out of general use due to stringent government regulations on human exposure limits.

A low concentration solution, typically 0.5%, is used as a storage agent for RO and UF membranes, ion exchange resins, and storage and distribution systems. In higher concentrations, typically a 4% solution, formaldehyde is used as a shock treatment to sanitize dialysis and other hospital water-based systems. To date, a complete substitute for formaldehyde has not been found.

– Quaternary Ammonium

Quaternary ammonium compounds are most commonly used as sanitizing agents in pharmaceutical, food and medical facilities. These compounds are stable, noncorrosive, nonirritating and active against a wide variety of microorganisms. Surface activity is an advantage when cleaning is desirable.

However, quaternary ammonium compounds may cause foaming problems in mechanical operations and form films requiring long

rinse times. Quarternary ammonium compounds are not compatible with some polymeric membranes.

– Anionic Surfactants

Anionic surfactants have a limited biocidal activity against the kinds of bacteria (gram-negative) commonly found in pure water systems.

• Physical Treatments

– Heat

Heat is a classic form of bacterial control and is very effective when systems are properly designed and installed. Temperatures of 80°C (176°F) are commonly used in pharmaceutical facilities for storage and **recirculation** of USP purified water and WFI. Heat treatment above 80°C (176°F) is also used to control microorganisms in activated carbon systems.

– Ultraviolet Light (UV)

Treatment with ultraviolet light is a popular form of disinfection due to ease of use. Water is exposed at a controlled rate to ultraviolet light waves. The light deactivates DNA leading to bacterial reduction. With proper design and maintenance, UV systems are simple and reliable for a high reduction in bacteria (99+ %), and are compatible with chemically-sensitive membrane and DI systems which are often incompatible with chemicals.

UV is used to reduce microbial loading to membrane systems and to maintain low bacterial counts in **high-purity water** storage and recirculation systems. If ozone has been added to water, UV is effective in destroying ozone residuals prior to end use. UV will increase the conductivity of water when organics are in the solution due to the breakdown of the organics and formation of weak organic acid.

The disadvantage of UV light is lack of an active residual, and it is effective only if there is direct UV light contact with the microbes. Careful system design and operation is required to ensure bacterial reduction. Inadequate light may only damage bacteria, which can recover. The water must be free of suspended solids that can “shadow” bacteria from adequate UV contact.

– Point-of-Use Microfiltration

Most bacteria have physical diameters in excess of 0.2 micron. Thus, a 0.2-micron or smaller-rated filter will mechanically remove

bacteria continuously from a flowing system. Point-of-use microfiltration is commonly used in pharmaceutical, medical, and microelectronics applications as assurance against bacterial contamination. To be used as a sterilizing filter, filters must be absolute rated (i.e., complete retention of particles equal to or larger than the filter micron rating). For pharmaceutical and medical applications these filters must undergo **validation** by means of a rigorous bacteria challenge test. Individual filters must be integrity-tested when in place in the system to ensure that the filter is properly sealed and defect-free. The greatest advantage of microfiltration is that neither chemicals nor heat is required. Filters must be changed on a regular basis to prevent the possibility of grow-through or pressure breakthrough.

5.0 EXAMPLES OF HIGH-PURITY WATER TREATMENT SYSTEMS

Each water purification situation is different. Feedwater composition varies as widely as purification requirements. However, some general hardware configurations are described here which have proven both efficient and cost-effective for common applications.

Feedwater and/or product water specifications may vary substantially from those described here, possibly requiring additional or alternative treatment methods. A water treatment professional should be consulted before designing a new water treatment system or modifying an existing system.

5.1 Potable Water

Residential Water Purification System

With the growing awareness of water quality concerns among the general public, many homeowners are installing under-the-sink or point-of-entry water purification systems to augment municipal treatment and/or their home water softener or iron filter.

The most complete system would use reverse osmosis to reduce TDS by approximately 90%, activated carbon to adsorb small molecular weight organics and chlorine, and final submicron filtration to remove carbon fines, other particles and bacteria which may grow in the carbon filter.

Most municipal water supplies in North America meet or exceed the World Health Organization (**WHO**) standard for potable water. However, several possible areas of concern exist, such as THM's, hydrocarbon compounds, and heavy metals. Within the residence, contamination from lead solder in the pipes may also be a concern.

- Product water: up to 1 gpm (3.8 Lpm) on demand; removal of 90% of lead, aluminum, and hydrocarbon compounds (Figure 32).

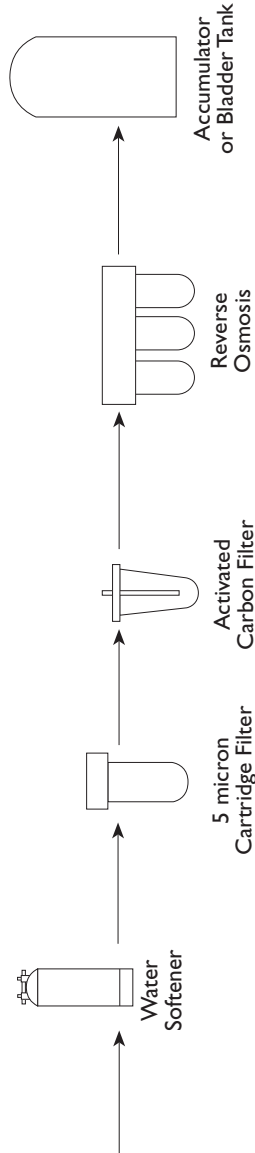

Figure 32 – Home RO

Typical system used to meet standards. Other modifications are dependent upon concentration of feed, quality of water required, and other objectives.

5.2 Kidney Dialysis

The suggested limits and treatment methods outlined are based on standards published by the Association for the Advancement of Medical Instrumentation (AAMI) and the American Society for Artificial Internal Organs (ASAIO). The methods selected are also based on AAMI recommendations as contained in the handbook “American National Standards, **Hemodialysis Systems.**” The medical concern is to eliminate **hemolysis** in the blood, and the potential for pyrogenic reactions. See Appendix for AAMI water standards.

Single-Patient Dialysis

- Specifications: 12 gph (345 Lph) requirement at 20 psi (1.4 bar) pressure required
- Feedwater: 400 ppm TDS; 2.0 mg/L chlorine 77°F (25°C)

- **Pre-Treatment**

Activated Carbon Filtration

Ten-inch Filter Housing with 5-micron Blown Microfiber Prefilter

- **Reverse Osmosis Unit**

Permeate Capacity: 14.5 gph (55 Lph) at 77°F (25°C)

Recovery: 33%

- **Options to Consider**

Chlorine Test Kit

Portable Conductivity Meter

Water Softener

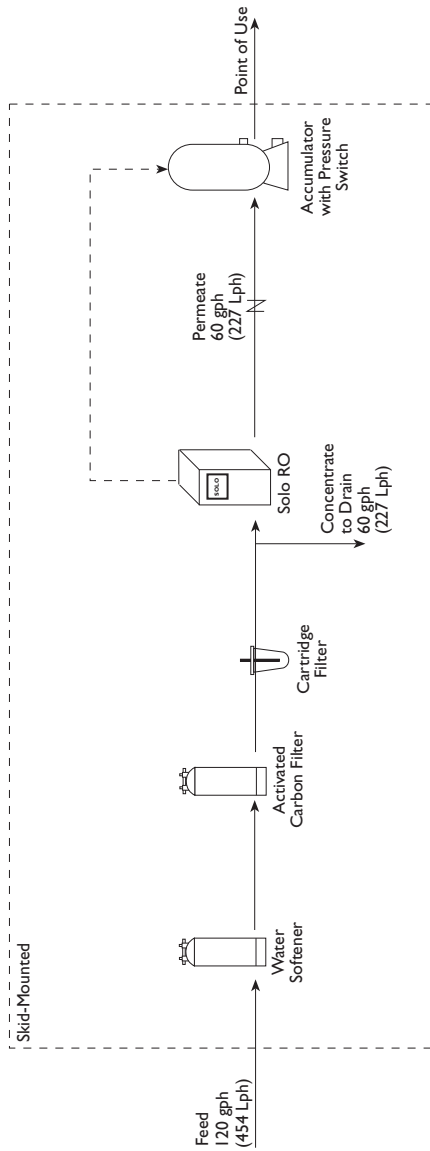

Figure 33 – Single-Patient Dialysis

Typical system used to meet standards. Other modifications are dependent upon concentration of feed, quality of water required, and other objectives.

15-Bed, In-Center Dialysis System, with Recycle

- Specifications: 3.0 gpm (11.5 Lpm) requirement; some storage required with continuous recycle to storage
- System designed to meet AAMI Standards
- Feedwater: 400 ppm TDS; 2.0 mg/L free chlorine; 13.9 gpg hardness; 77°F (25°C)

• Pre-Treatment

Water Softener (24 hours of operation between regenerations)
Activated Carbon Filter

• Reverse Osmosis Unit

Permeate Capacity: 188 gph (712 Lph) at 77°F (25°C)

• Storage and Distribution

Storage Tank with 0.2-micron Air Filter
Pressure Regulator Valve
Float Switch
Stainless Steel Transfer Pump System for Continuous Recycle
Pressure Relief Valve

• Options to Consider

pH Sensor
Clean-In-Place System
pH Test Kit
Chlorine Test Kit
Portable Conductivity Meter
Mixed-Bed Deionizers
UV Light for Continuous Disinfection

HIGH-PURITY WATER TREATMENT SYSTEMS

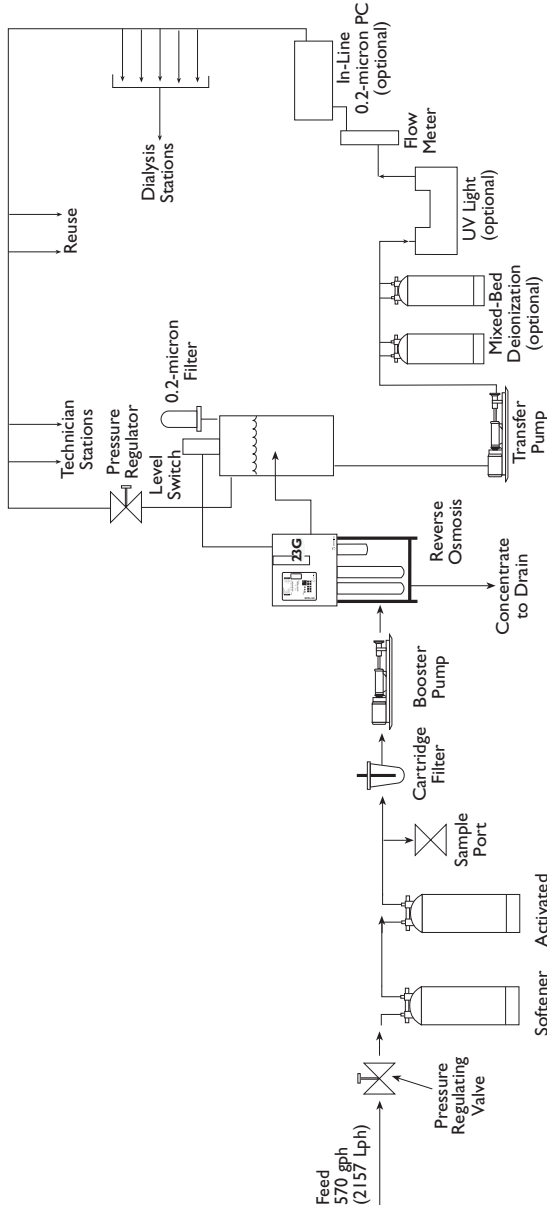

Figure 34 – In-Center Dialysis System with Recycle

Typical system used to meet standards. Other modifications are dependent upon concentration of feed, quality of water required, and other objectives.

14-Bed, In-Center Dialysis, Continuous Flow Direct Feed

- Specifications: 140 gph (530 Lph) requirement with positive pressure to feed dialysis units directly
- Feedwater: 400 ppm TDS; 2.0 mg/L free chlorine; 13 gpg hardness; 77°F (25°C)

• Pre-Treatment

(24-hour operation of pre-treatment between regeneration or backwash cycles)

Tempering Control Valve

Dual-Media Filter (not shown)

Water Softener (not shown)

Activated Carbon Filter

• Reverse Osmosis Unit

Permeate Capacity: 168 gph (635 Lph) at 77°F (25°C)

• Post-Treatment

Pressure Relief Valve

• Options to Consider

pH Sensor

Clean-In-Place System

Portable Conductivity Meter

Chlorine Test Kit

Note: Water heater capacity must be adequate to raise water temperature to 77°F (25°C).

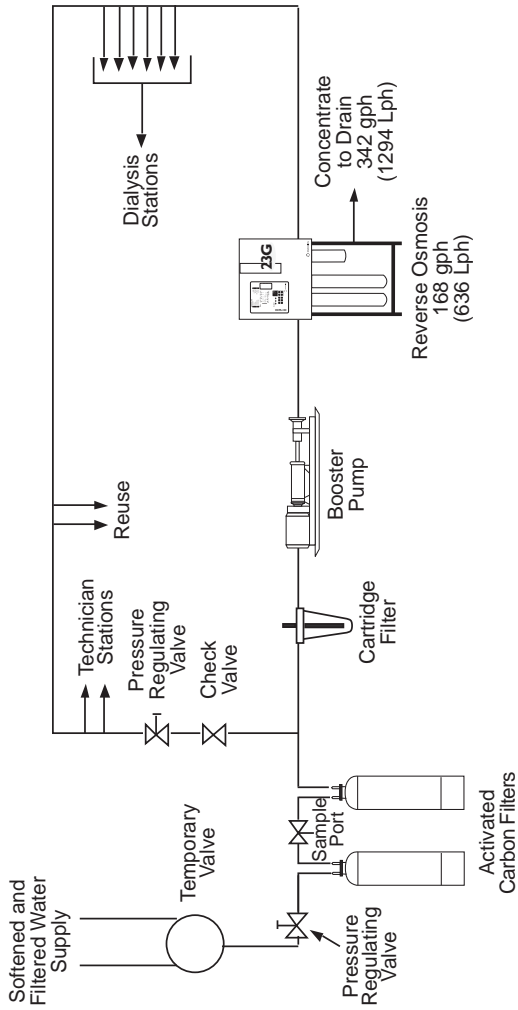

Figure 35 – In-Center Dialysis, Continuous Flow System

Typical system used to meet standards. Other modifications are dependent upon concentration of feed, quality of water required, and other objectives.

5.3 Commercial-Scale Purified Water Treatment System

- Specifications: 40 gph (151 Lph) requirement; pressurized storage desired; water to be used for rinsing glassware
- Feedwater: 25 gpg hardness; 800 ppm TDS; 65°F (18°C)

- **Pre-Treatment**

Water Softener (24 hours of operation between regenerations)

Activated Carbon (24 hours of operation between backwash cycles)

- **Reverse Osmosis Unit**

Permeate Capacity: 41 gph (155 Lph) at 77°F (25°C) at 30 psig
(2.1 bar) backpressure

- **Storage and Distribution**

Pressurized Storage System

- **Options to Consider**

pH Test Kit

Chlorine Test Kit

Portable Conductivity Meter

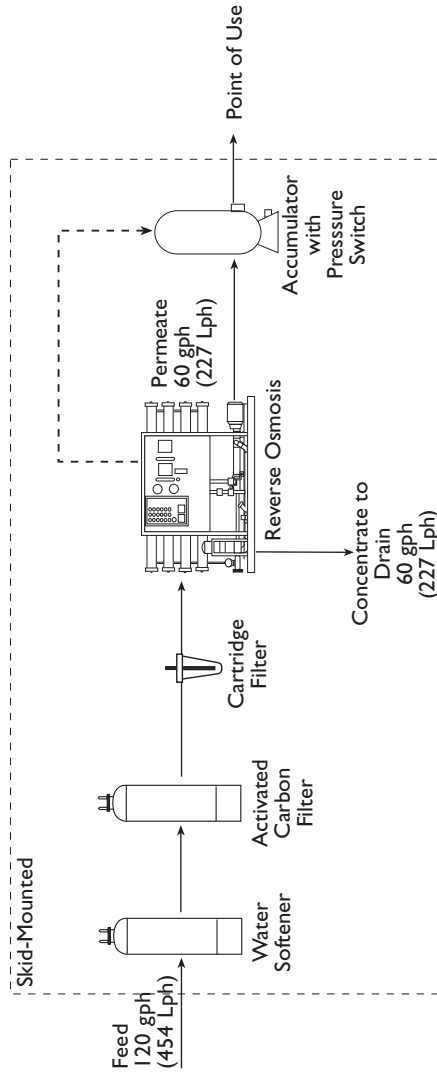

Figure 36 – Commercial Water System with Pressurized Storage

Typical system used to meet standards. Other modifications are dependent upon concentration of feed, quality of water required, and other objectives.

5.4 Water for Pharmaceutical Use

The prevailing water standards for pharmaceutical use are set forth by the United States Pharmacopoeia (**USP**).

The USP specifications require that “Water for Injection” (**WFI**) be produced only by distillation or reverse osmosis. “Purified Water” may be purified by distillation, reverse osmosis, ion exchange, or by a “suitable method.”

There is a clear distinction between purified water and Water For Injection. WFI must also meet a bacterial endotoxin (pyrogen) specification. USP purified water has a number of pharmaceutical and cosmetic water applications, including higher volume uses such as container-rinsing. WFI is used for the preparation of parenteral (injectable) solutions. See Appendix for USP Purified Water and WFI quality standards.

USP Purified Water System

- **Pre-Treatment**

- Chemical Feed System for Chlorine Injection

- Dual-Media Filter

- Water Softener

- Chemical Feed Systems for Sodium Metabisulfite and Sodium Hydroxide Addition

- **Reverse Osmosis Units**

- Permeate Capacity: 1200 gpm (4800 Lpm) and 75% recovery
 - Second-Pass RO

- Permeate Capacity: 900 Lpm and 70 to 75% recovery

- **Post-Treatment**

- Storage Tank with 0.2-micron Air Filter

- Stainless Steel Distribution Pump System

- Storage Tank

- Pressure Relief Valve

HIGH-PURITY WATER TREATMENT SYSTEMS

• **Options to Consider**

- Clean-In-Place System
- Portable Conductivity Meter
- pH Test Kit
- Chlorine Test Kit
- Ozonation System with UV Destruct for Sanitization of Distribution Loop

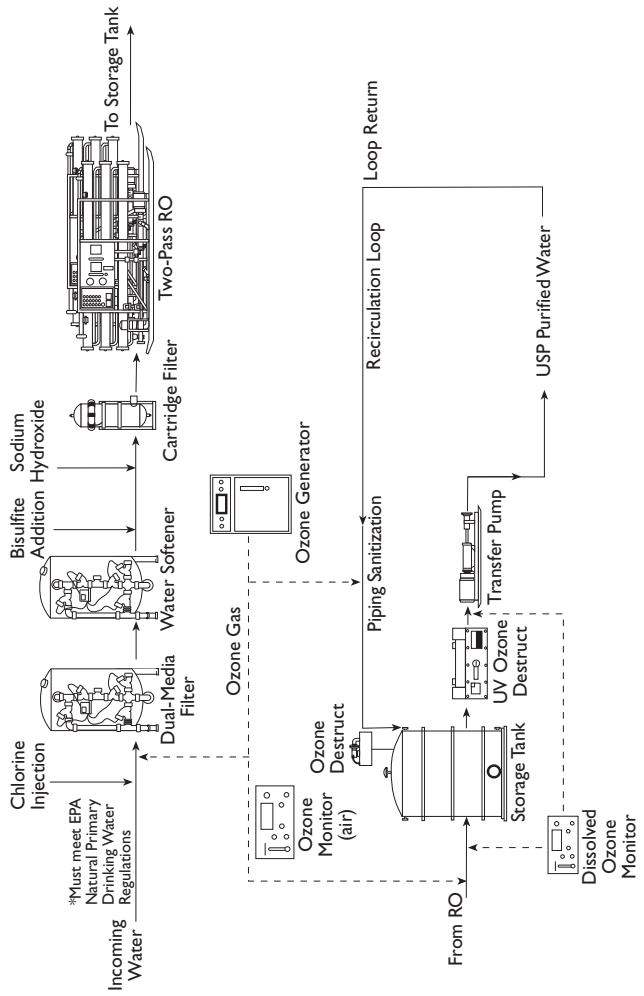

Figure 37 – USP Purified Water System

Typical system used to meet standards. Other modifications are dependent upon concentration of feed, quality of water required, and other objectives.

USP Water for Injection (WFI) System

- Specifications: 30 gph (114 Lph) designed to meet specifications
- Feedwater: 12.1 gpg hardness; 250 ppm TDS; 65°F (18°C)

- **Pre-Treatment**

Chemical Feed System for Chlorine Injection

Dual-Media Filter

Water Softener (24-hour operation of softener between regenerations) or chemical feed for reducing pH

- **Reverse Osmosis Unit**

Permeate Capacity: 42 gph (159 Lph) at 77°F (25°C)

- **Activated Carbon Filter**

- **Distillation Unit**

High Velocity Single-Effect Still

- **Options to Consider**

Clean-In-Place for RO

Portable Conductivity Meter

pH Test Kit

Chlorine Test Kit

Automatic Still Control

Resistivity Meter

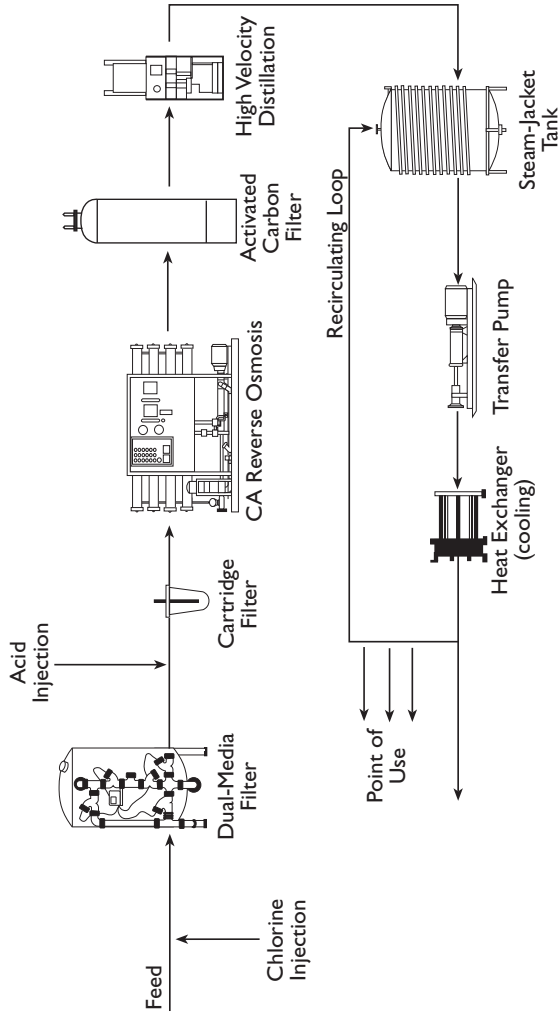

Figure 38 – USP Water for Injection (WFI) System

Typical system used to meet standards. Other modifications are dependent upon concentration of feed, quality of water required, and other objectives.

5.5 Boiler Feed and Power Generator Water

The requirements for water quality vary greatly with the type of boiler system. Boiler water treatment constitutes a science in itself and any attempt at an in-depth discussion would go beyond the intentions of this publication. However, some basic approaches to mechanical treatment, rather than chemical treatment, can be outlined.

The primary concerns are related to scale prevention, corrosion protection, and **blowdown** control.

Problem	Cause	Remedy
scale buildup	water hardness, silica	water softener, reverse osmosis, ion exchange
corrosion	chlorides, oxygen	reverse osmosis, ion exchange, vacuum degasifier
TOC	water supply organics	reverse osmosis, activated carbon
frequent blowdown	high TDS	reverse osmosis, ion exchange

HIGH-PURITY WATER TREATMENT SYSTEMS

Although this description may be simplistic, many common problems related to boiler feed can be solved by controlling water hardness, alkalinity, silica and total solids. The simplest method to control most of these problems is reverse osmosis. The technology is straightforward and can reduce blowdown frequency by a factor up to 10.

High-Pressure Steam Generation

- 200 gpm (757 Lpm) requirement
- Feedwater: 500 ppm TDS; 77°F (25°C)

• Pre-Treatment

Chemical Feed System for Addition of Chlorine
Dual-Media Sediment Filter
Chemical Feed System for pH Buffering

• Reverse Osmosis Unit

Permeate Capacity: 200 gpm (757 Lpm) at 77°F (25°C)

• Storage and Distribution

Storage Tank with 0.2-micron Air Filter
Float Switch
Stainless Steel Distribution Pump System

• Post-Treatment

Two-Bed Ion Exchange, Cation Resin
Forced-Draft Degasifier
Two-Bed Ion Exchange, Anion Resin
Mixed-Bed Ion Exchange

• Options to Consider

pH Controller-Indicator
Clean-In-Place System
Portable Conductivity Meter
pH Test Kit
Chlorine Test Kit
Chemical Feed System for Chlorine Injection
Second-Pass RO

HIGH-PURITY WATER TREATMENT SYSTEMS

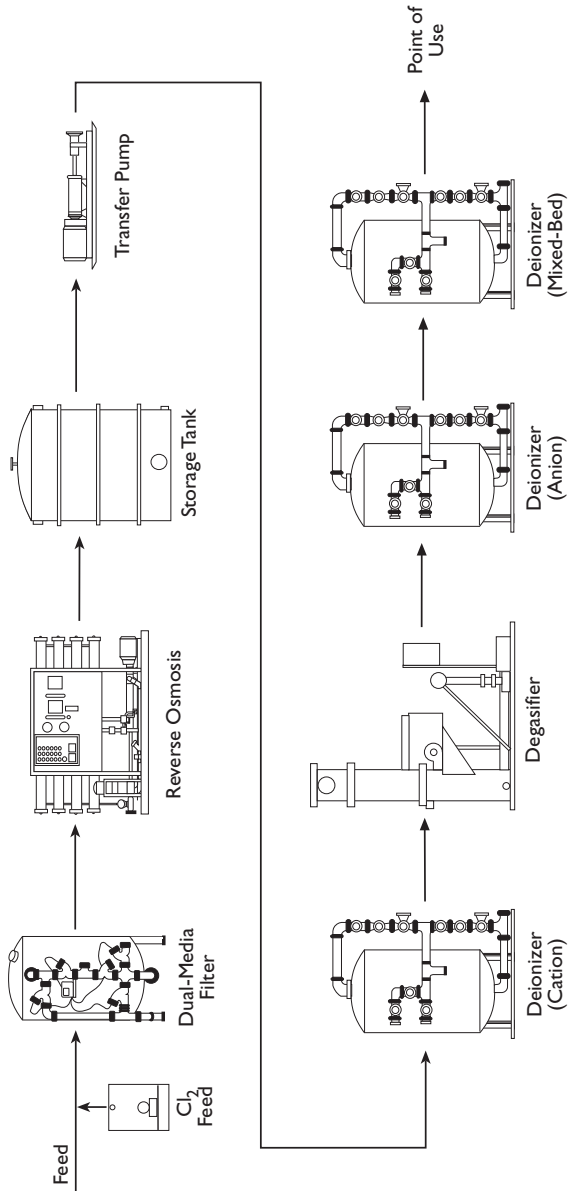

Figure 39 – Treatment System for High-Pressure Steam Generation

Typical system used to meet standards. Other modifications are dependent upon concentration of feed, quality of water required, and other objectives.

5.6 Potable Water / Boiler Feed / Humidification / General Rinse

- Specifications: 12 gpm (45 Lpm); some storage required; designed to meet general water requirements for these and similar applications
- Feedwater: 800 ppm TDS; 77°F (25°C)

- **Pre-Treatment**

Chemical Feed System for Addition of Chlorine

Dual-Media Sediment Filter

Chemical Feed System for pH Buffering

- **Reverse Osmosis Unit**

Permeate Capacity: 720 gph (2725 Lph) at 77°F (25°C)

- **Storage and Distribution**

Storage Tank with 0.2-micron Air Filter

Float Switch

Stainless Steel Distribution Pump System

Accumulator Tank

- **Options to Consider**

pH Controller-Indicator

Clean-In-Place System

Portable Conductivity Meter

pH Test Kit

Chlorine Test Kit

Chemical Feed System for Chlorine Injection

UV Light on Permeate Line

HIGH-PURITY WATER TREATMENT SYSTEMS

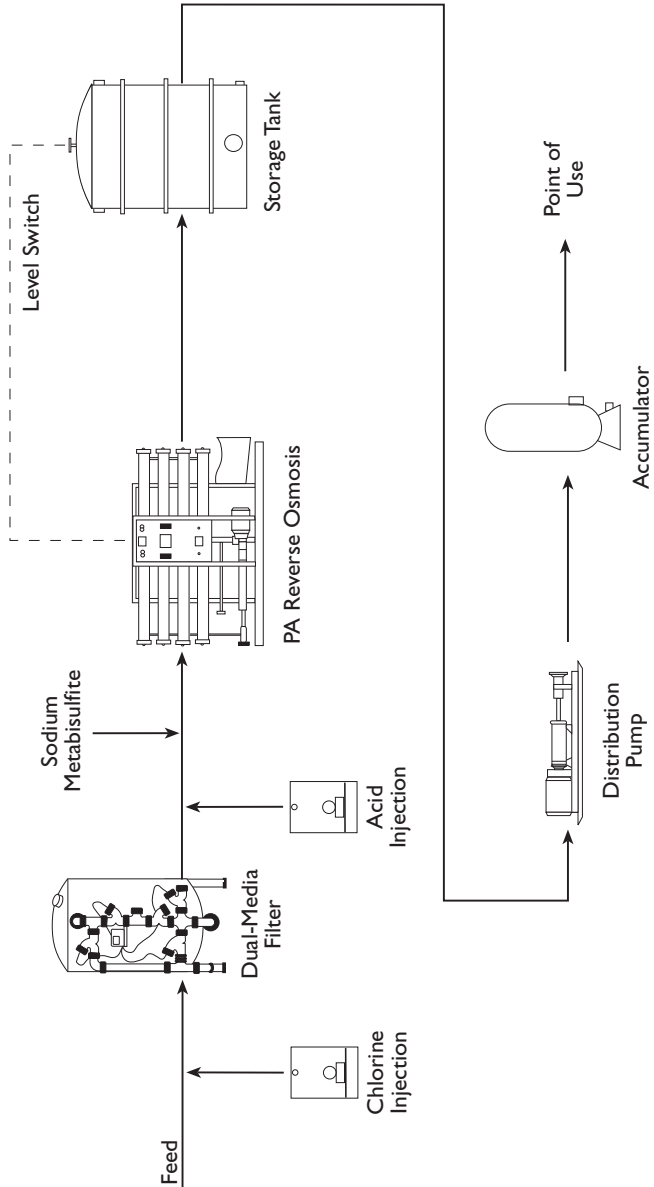

Figure 40 – Industrial Boiler Feed/Humidification System

Typical system used to meet standards. Other modifications are dependent upon concentration of feed, quality of water required, and other objectives.

HIGH-PURITY WATER TREATMENT SYSTEMS

NOTES:

5.7 Water for Electronics

The process of manufacturing semiconductors requires some of the highest-quality ultrapure water attainable, and in great quantities. The most important reference standards are those of the American Society for Testing and Materials (**ASTM**) and Semiconductor Equipment and Materials International (**SEMI**). See Appendix for water standards.

Achieving this high quality requires the use of virtually all the technology available to the water treatment specialist. **Chlorination**, filtration, softening, carbon filtration, reverse osmosis, deionization, ultrafiltration, microfiltration, ozonation, vacuum degasification, and ultraviolet sterilization are all commonly used in the production of ultrapure water. In addition to the treatment technologies, the design and operation of the storage and distribution systems are also extremely critical.

Ultrapure Water (18 megohm)

- Specifications: 30 gpm (114 Lpm) intermittent; some storage required
- Feedwater: 12 gpg hardness; 400 ppm TDS; 51°F (11°C)

• Pre-Treatment

Chemical Feed System for Chlorine Injection
Dual-Media Sediment Filter
Chemical Feed System for pH Buffering
Heat Exchanger for Preheating Feed H₂O

• Reverse Osmosis

Permeate Rate 2216 gph (8388 Lph) at 77°F (25°C)

• Vacuum Degasifier

• Reverse Osmosis Unit

Permeate Rate: 1662 gph (6291 Lph) at 77°F (25°C)

• Ozonator

1 lb/day (0.45 kg/day)

• Storage and Distribution

Storage Tank using a Nitrogen Blanket
Float Switch
Transfer Pump

• Post-Treatment

Primary Mixed-Bed Ion Exchange
Polishing Mixed-Bed Ion Exchange
Mixed-Bed Ion Exchange Polisher
Post-DI 0.2-micron Filter and Housing
Ozonation

• Options to Consider

Clean-In-Place System
Portable Conductivity Meter
Ultraviolet Sterilizer
Point-of-Use Filter and Housing
Vacuum Degasifier

OR

Ultrapure Water Polishing (Ultrafiltration)

HIGH-PURITY WATER TREATMENT SYSTEMS

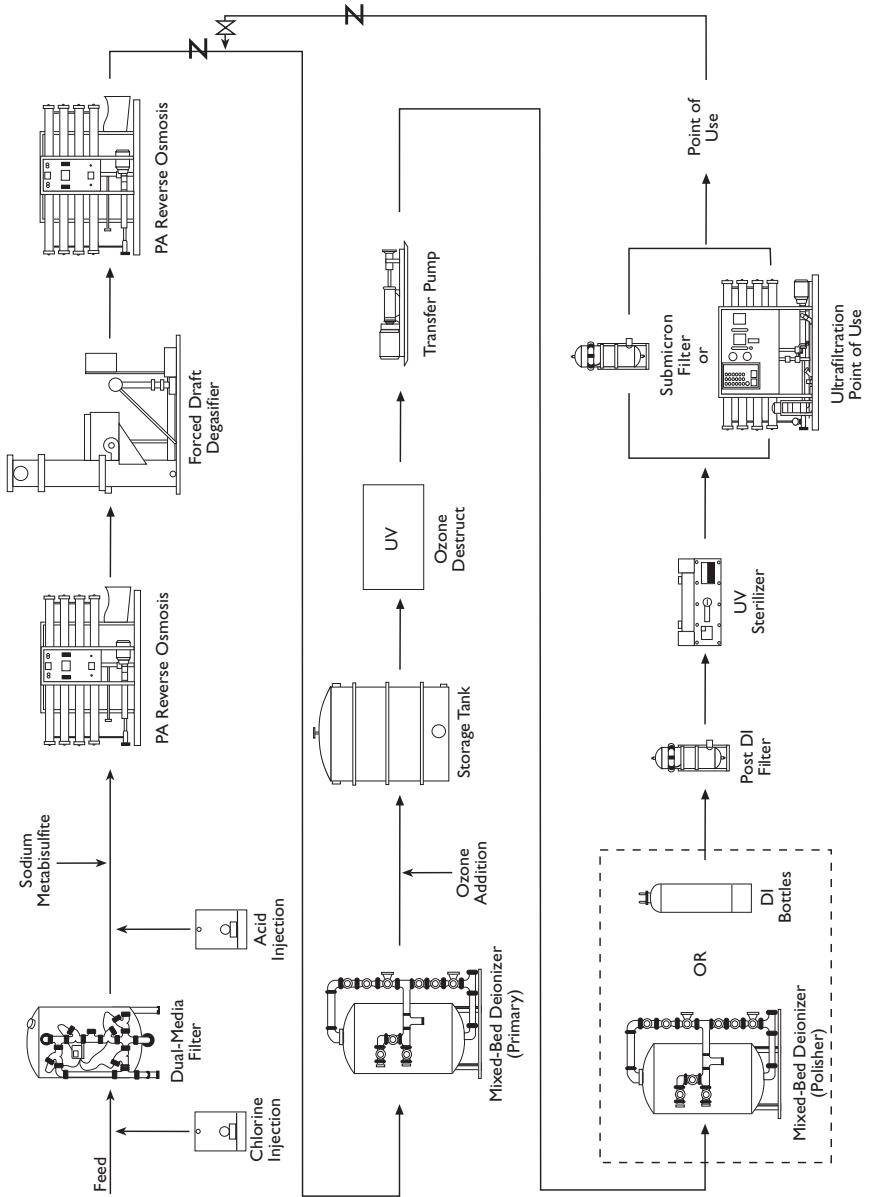

Figure 41 – Electronics-Grade Water System

Typical system used to meet standards. Other modifications are dependent upon concentration of feed, quality of water required, and other objectives.

5.8 Water for Laboratory Use

The standards for “**reagent-grade**” laboratory water are set by ASTM and the College of American Pathologists (**CAP**). See Appendix for water standards.

Production of laboratory-grade water usually involves some combination of reverse osmosis, deionization, and distillation, which can be categorized as follows:

<u>Type</u>	<u>Methods to Obtain</u>
ASTM I	RO -> DI -> 0.2 micron MF Still -> DI -> 0.2 micron MF
CAP I	RO -> Still or RO -> DI
ASTM II	RO -> Still or DI -> Still
ASTM III	Still or RO or DI (or combination) -> 0.45-micron MF
CAP II	Still or DI
CAP III	Still or RO or DI (or combination)
ASTM IV	Still or RO or DI (or combination)

The suggested methods are relative and will change depending upon feedwater quality, quantity and flow required, plus distribution considerations. See Appendix for reagent-grade water quality standards.

Reagent-Grade Water for Laboratory Use

Specifications: 10 gph (38 Lph) requirement

System designed for general-use laboratory-grade water

Feedwater: 250 ppm TDS; 10 gpg hardness; 77°F (25°C)

- **Pre-Treatment**

Water Softener (24 hours of operation between regenerations)

HIGH-PURITY WATER TREATMENT SYSTEMS

- **Reverse Osmosis Unit**

Permeate Capacity: 13 gph (49 Lph) at 77°F (25°C)

- **Post-Treatment**

Pressurized Storage System

High-Purity Water Loop

Capacity: 1 gpm (4 Lpm)

Suggested Cartridges:

Activated Carbon (1 each)

Mixed-Bed Resin (2 each)

0.2-micron Final Filter

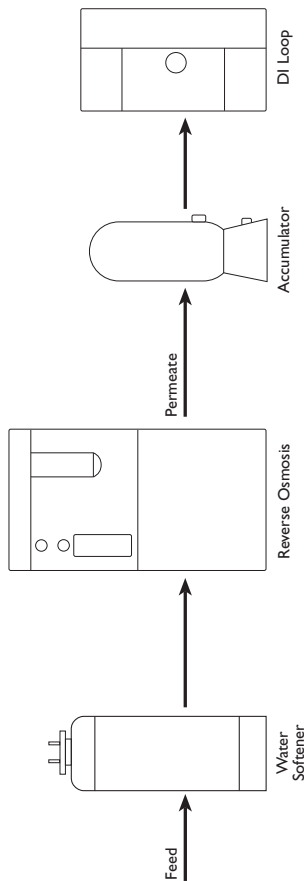

Figure 42 – Point-Of-Use System (ASTM Type I)

Typical system used to meet standards. Other modifications are dependent upon concentration of feed, quality of water required, and other objectives.

5.9 Water for Beverage Manufacturing

Much attention has been focused recently on the quality of water used for beverage production. The term “beverage” here includes soft drinks, reconstituted juices and **bottled water**. While recognized specifications are lacking, concerns include bacteria, sodium, alkalinity, water hardness and total dissolved solids. These problems are increasing as local water supplies vary and deteriorate, and consumers become more sophisticated in their taste requirements. Also, the Food and Drug Administration (**FDA**) has developed standards for sodium labeling.

Because the parameters are often set by the user-industry as opposed to a regulatory agency, the following ideas suggest approaches to each industry.

Bottled Water

Primary Concerns: bacteria and yeast; total solids content

The bottled water industry must produce a product within the guidelines of certain definitions. A partial list includes “distilled water,” “pure water,” “spring water” and “mineral water.” Carefully define the requirement and obtain a definition of the desired product water quality.

Treatment Methods: In all cases, bacterial control is critical.

Disinfection using chlorination or ozonation is usually required. Where taste or chemicals are a consideration, disinfection by ozone is preferred. The total solids content is usually most economically controlled by reverse osmosis. The label on the bottle should define the method of production.

Soft Drinks

Primary Concerns: bacteria and yeast, sodium, alkalinity, chlorine

For a soft drink to be labeled “low sodium” or “sodium-free,” the product must meet the FDA’s guidelines. Usually this requires a form of **demineralization**. Once again, reverse osmosis is often the method of choice due to ease of operation and economics.

Juices

Primary Concern: bacteria and yeast

Because reverse osmosis removes more than 99% of bacteria from high volumes of water, it is a common treatment method for juice water. Ozone sanitation is also an effective method. Chemical disinfection methods such as chlorine may impact the taste of the beverage.

Beverage Water Requirements

Specifications: 50 gpm (189 Lpm); some storage required;
designed to meet low sodium requirements for soft drinks
Feedwater: 800 ppm TDS, 77°F (25°C)

• Pre-Treatment

Chemical Feed System for Addition of Chlorine
Dual-Media Sediment Filter
Chemical Feed System for pH Buffering

• Reverse Osmosis Unit

Permeate Capacity: 50 gpm (189 Lpm) at 77°F (25°C)

• Storage and Distribution

Storage Tank with 0.2-micron Air Filter
Float Switch
Stainless Steel Distribution Pump System

• Post-Treatment

Activated Carbon Filter, Steam-Sterilizable
Post-Carbon Cartridge Filter, 5-micron
Submicron Cartridge Filter, 0.2-micron

• Options to Consider

pH Controller-Indicator
Clean-In-Place System
Portable Conductivity Meter
pH Test Kit
Chlorine Test Kit
Chemical Feed System for Chlorine Injection

HIGH-PURITY WATER TREATMENT SYSTEMS

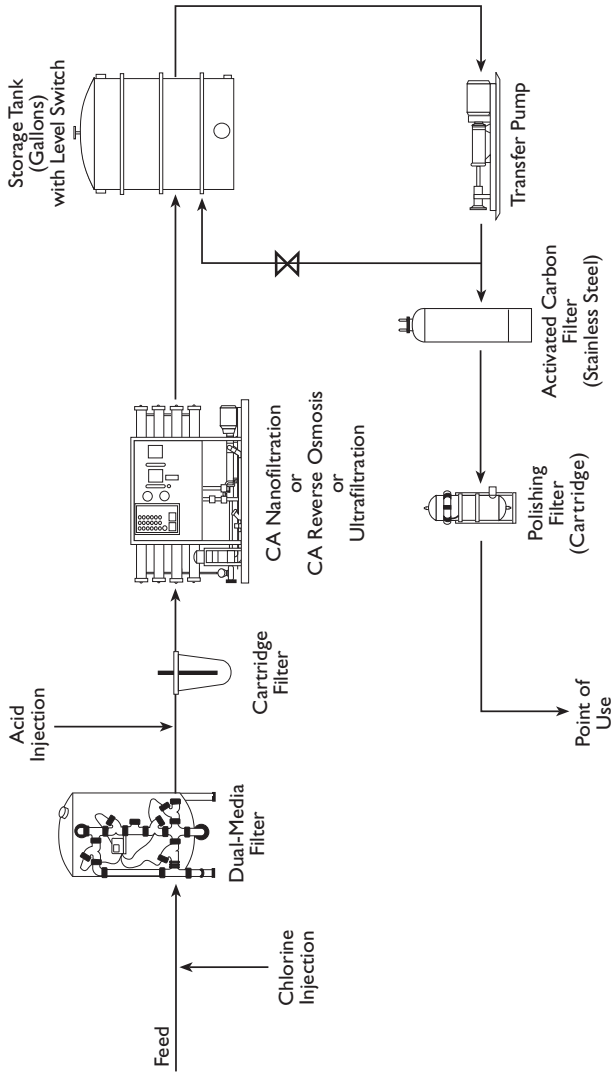

Figure 43 – Beverage Water Treatment System

Typical system used to meet standards. Other modifications are dependent upon concentration of feed, quality of water required, and other objectives.

Bottled Water Requirements

- Specifications: 40 gpm (151 Lpm); some storage required; designed to meet low-sodium water requirements for bottled water
- Feedwater: 650 ppm TDS; 77°F (25°C)

• Pre-Treatment

Chemical Feed System for Addition of Chlorine
Dual-Media Sediment Filter
Chemical Feed System for pH Buffering

• Reverse Osmosis Unit or Nanofiltration Unit

Permeate Capacity: 40 gpm (151 Lpm) at 77°F (25°C)

• Ozone Unit

Capacity: 1 lb/day (19 gr/hr)

• Storage and Distribution

Contact Tower
Ozone Destruct Unit
Stainless Steel Distribution Pump System

• Options to Consider

pH Controller-Indicator
Clean-In-Place System
Portable Conductivity Meter
pH Test Kit
Chlorine Test Kit
Storage Tank
Deionizer
Still
Transfer Pump

HIGH-PURITY WATER TREATMENT SYSTEMS

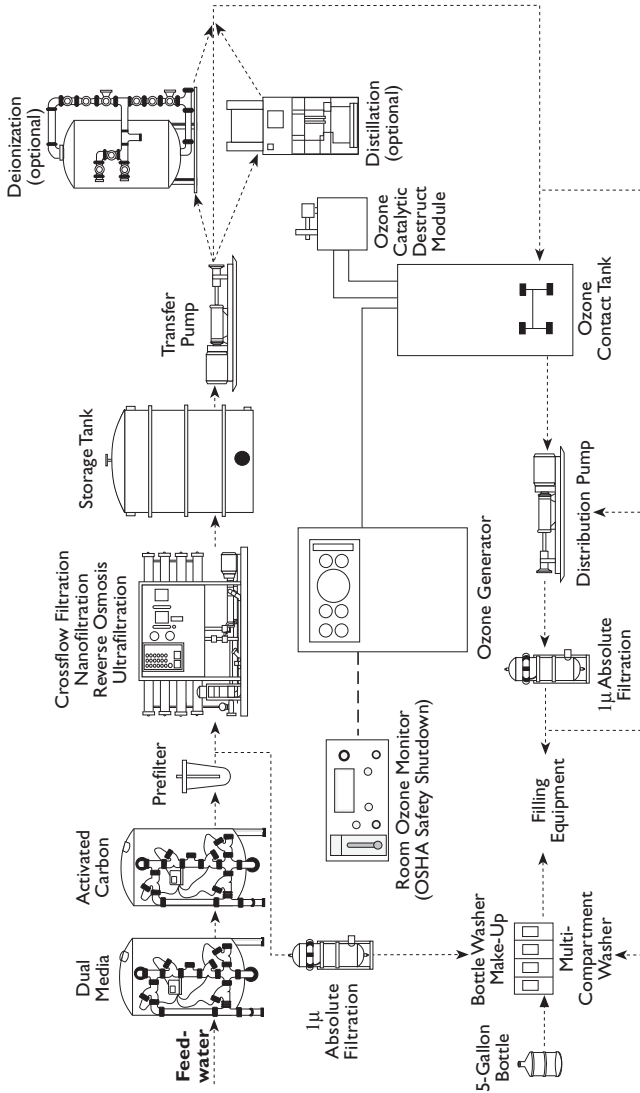

Figure 44 – Bottled Water Treatment System

Typical system used to meet standards. Other modifications are dependent upon concentration of feed, quality of water required, and other objectives.

6.0 WATER PURIFICATION INTO THE 21ST CENTURY

Four trends are occurring throughout the world which indicate increased applications for water purification in the 21st century. The first is deterioration of water supplies from increased use and disposal of chemicals. Second is the development of increasingly sensitive instruments capable of detecting water contaminants in the parts per billion and even parts per trillion range. Third is the growing sophistication of the general public's knowledge of water quality and the regulating authorities' response in mandating high standards. Fourth is the development of new or refined high-technology products and biotechnology products which require ultra pure water as part of their manufacture. Water treatment techniques will require even greater sophistication in years ahead.

7.0 APPENDICES

7.1 Appendix A: U.S. National Drinking Water Regulations (as of February 1996)

Table 1: Summary of U.S. Primary Drinking Water Regulations (as of February 1996)

<u>Contaminant</u>	<u>Unit</u>	<u>Current MCL</u>	<u>Status</u>	<u>Proposed MCL² MCLG¹</u>	
PRIMARY REGULATIONS, INORGANICS					
Antimony	mg/L	0.006	Final	0.01/0.005	0.005
Arsenic	mg/L	0.05	Interim		–
Asbestos (>10µm)	–	7 mil fibers/L	Final		7 mil fibers/L
Barium	mg/L	2.0	Final		2.0
Beryllium	mg/L	0.004	Final		Zero
Cadmium	mg/L	0.005	Final		0.005
Chromium (total)	mg/L	0.1	Final		0.1
Copper	mg/L	1.3	Final		1.3
Cyanide (Free)	mg/L	0.2	Final		0.2
Fluoride	mg/L	4.0	Final		4.0
Lead	mg/L	0.015	Final		Zero
Mercury	mg/L	0.002	Final		0.002
Nickel	mg/L	0.1	Final		0.1
Nitrate (as N)	mg/L	10.0	Final		10.0
Nitrite (as N)	mg/L	1.0	Final		N/A
Total Nitrate and Nitrite (as N)	mg/L	10.0	Final		10.0
Selenium	mg/L	0.05	Final		0.05
Sulfate	mg/L	–	Proposed	500	500
Thallium	mg/L	0.002	Final		0.0005
MICROBIALS					
Total Coliforms ³		Zero			Zero
		(presence/absence)			
Giardia Lamblia		Treatment technique			Zero
Heterotrophic Bacteria (Standard Plate Count)		Treatment technique			N/A
Legionella		Treatment technique			Zero

APPENDIX A

Table 1 (Cont'd)

<u>Contaminant</u>	<u>Unit</u>	<u>Current MCL</u>	<u>Status</u>	<u>Proposed MCL</u>	<u>MCLG</u>
MICROBIALS cont.					
Turbidity	btu	0.5 to 1.0			N/A
Viruses		Treatment technique			Zero
E. Coli		Zero			Zero
Fecal Coliforms		Zero			Zero
Cryptosporidium			Proposed	Treatment technique ⁴	Zero
VOLATILE ORGANIC CHEMICALS					
Benzene	mg/L	0.005	Final		Zero
Carbon Tetrachloride	mg/L	0.005	Final		Zero
para-Dichlorobenzene	mg/L	0.075	Final		0.075
1,2-Dichloroethane	mg/L	0.005	Final		Zero
1,1-Dichloroethylene	mg/L	0.007	Final		0.007
1,1,1-Trichloroethane	mg/L	0.2	Final		0.2
Trichloroethylene	mg/L	0.005	Final		Zero
Vinyl Chloride	mg/L	0.002	Final		Zero
cis-1,2-Dichloroethylene	mg/L	0.07	Final		0.07
1,2 Dichloropropane	mg/L	0.005	Final		Zero
Ethylbenzene	mg/L	0.7	Final		0.7
Monochlorobenzene	mg/L	0.1	Final		0.1
o-Dichlorobenzene	mg/L	0.6	Final		0.6
Styrene	mg/L	0.1	Final		0.1
Tetrachloroethylene	mg/L	0.005	Final		Zero
Toluene	mg/L	1.0	Final		1.0
trans-1,2-Dichloroethylene	mg/L	0.1	Final		0.1
Xylenes (Total)	mg/L	10.0	Final		10.0
PESTICIDES, HERBICIDES, PCB's					
Alachlor (Lasso)	mg/L	0.002	Final		Zero
Aldicarb (Temik)	mg/L		Delayed	0.003	0.001
Aldicarb Sulfone	mg/L		Delayed	0.002	0.001
Aldicarb Sulfoxide	mg/L		Delayed	0.004	0.001
Atrazine	mg/L	0.003	Final		0.003
Carbofuran	mg/L	0.04	Final		0.04
Chlordane	mg/L	0.002	Final		Zero
Dalapon	mg/L	0.2	Final		0.2
Dibromochloropropane (DBCP)	mg/L	0.0002	Final		Zero



Table 1 (Cont'd)

<u>Contaminant</u>	<u>Unit</u>	<u>Current MCL</u>	<u>Status</u>	<u>Proposed MCL</u>	<u>MCLG</u>
Dinoseb	mg/L	0.007	Final		0.007
Diquat	mg/L	0.02	Final		0.02
2,4-D	mg/L	0.07	Final		0.07
Endothall	mg/L	0.1	Final		0.1
Endrin	mg/L	0.002	Final		0.002
Ethylene Dibromide (EDB)	mg/L	0.00005	Final		Zero
Glyphosate	mg/L	0.7	Final		0.7
Heptachlor	mg/L	0.0004	Final		Zero
Heptachlor Epoxide	mg/L	0.0002	Final		Zero
Hexachlorocyclopentadiene	mg/L	0.05	Final		0.05
Lindane	mg/L	0.0002	Final		0.0002
Methoxychlor	mg/L	0.04	Final		0.04
Oxamyl (Vydate)	mg/L	0.2	Final		0.2
Pentachlorophenol	mg/L	0.001	Final		Zero
Pichloram	mg/L	0.5	Final		0.5
Polychlorinated biphenyls (PCBs)	mg/L	0.0003	Final		Zero
Simazine	mg/L	0.004	Final		0.004
Toxaphene	mg/L	0.005	Final		Zero
2,4,5-TP (Silvex)	mg/L	0.05	Final		0.05

DRINKING WATER, TREATMENT CHEMICALS

Acrylamide (0.05% dosed) at 1mg/L	-Treatment technique		Final		Zero
Epichlorohydrin (0.01% dosed at 2- mg/L	-Treatment technique		Final		Zero

ORGANICS

Benzo(a)pyrene	mg/L	0.0002	Final		Zero
Dichloromethane (Methylene Chloride)	mg/L	0.005	Final		Zero
Di(2-ethylhexyl)adipate	mg/L	0.4	Final		0.5
Di(2-ethylhexyl)phthalate	mg/L	0.006	Final		Zero
Hexachlorobenzene	mg/L	0.001	Final		Zero
Hexachlorocyclopentadiene (HEX)	mg/L	0.05	Final		0.05

APPENDIX A

Table 1 (Cont'd)

Contaminant	Unit	Current MCL	Status	Proposed MCL	MCLG
1,2,4-Trichlorobenzene	mg/L	0.07	Final		0.07
1,1,2-Trichlorethane	mg/L	0.005	Final		0.003
2,3,7,8-TCDD (Dioxin)	mg/L	3 x 10 ⁻⁸	Final		Zero

DISINFECTANT BY-PRODUCTS

Bromodichloromethane	mg/L		Proposed	N/A	Zero
Bromoform	mg/L		Proposed	N/A	Zero
Chloral Hydrate	mg/L		Proposed	Treatment Technique	0.04
Chloroform	mg/L		Proposed	N/A	Zero
Dibromochloromethane	mg/L		Proposed	N/A	0.06
Dichloroacetic Acid	mg/L		Proposed	N/A	Zero
Haloacetic Acids (Sum of 5, HAA5)	mg/L		Proposed	0.060 (Stage 1) 0.030 (Stage 2)	- -
Trichloroacetic Acid	mg/L			N/A	0.3
Trihalomethanes (Sum of 4, Total THM's)	mg/L	0.10	Interim		N/A
	mg/L		Proposed	0.080 (Stage 1)	N/A
	mg/L		Proposed	0.040 (Stage 2)	N/A
Bromate	mg/L		Proposed	0.010	Zero
Chlorite	mg/L		Proposed	1.0	0.08

DISINFECTANTS (MAXIMUM RESIDUAL LEVELS)

Chlorine	mg/L		Proposed	4 (as Cl ₂)	4 (as Cl ₂)
Chloramines	mg/L		Proposed	4 (as Cl ₂)	4 (as Cl ₂)
Chlorine Dioxide	mg/L		Proposed	0.8 (as ClO ₂)	0.3 (as ClO ₂)

RADIONUCLIDES

Gross Beta and Photon Emitters	-	4 mrem/year	Interim	4 mrem/year	Zero
Adjusted Gross Alpha Emitters	pCi/L	15	Interim	15	Zero
Radium-226	pCi/L	-	Proposed	20	Zero
Radium 228	pCi/L	-	Proposed	20	Zero
Radium-226 + Radium-228	pCi/L	5	Interim	-	-
Radon	pCi/L	-	Proposed	300	Zero
Uranium	µg/L	-	Proposed	20	Zero



Table 1 (Cont'd)

Notes:

- 1 Maximum contaminant level goal (MCLG) is a nonenforceable goal at which no known adverse health effects occur.
- 2 Maximum contaminant level (MCL) is a federally-enforceable standard.
- 3 Revised regulations will be based on presence/absence concept rather than an estimate of coliform density; effective December 1990.
- 4 Treatment Technique (TT) – requirements established in lieu of MCL's: effective beginning December 1990; MCL final for surface waters only.

**US Non-Enforceable
Secondary Regulations –
Secondary Maximum Contaminant Levels (SMCL's*)**

<u>Contaminant</u>	<u>SMCL's</u>
aluminum	0.05 mg/L
chloride	250 mg/L
color	15 color units
copper	1 mg/L
corrosivity	noncorrosive
fluoride	2 mg/L
foaming agents	0.5 mg/L
iron	0.3 mg/L
manganese	0.05 mg/L
odor	3 threshold odor number
pH	6.5 - 8.5
silver	-
sulfate	250 mg/L
total dissolved solids (TDS)	500 mg/L
zinc	5 mg/L

* SMCL's are federal, nonenforceable recommendations which establish limits for drinking water constituents that may affect the aesthetic quality of the water, and the public's acceptance of it as safe (e.g., taste and odor).

These levels represent reasonable goals for drinking water quality. The states may establish higher or lower levels, which may be appropriate depending upon local conditions such as lack of alternate source waters or other compelling factors, if public health and welfare is not adversely affected.

7.2 Appendix B: Electronic Grade Water

Four types of electronic grade water are described in the 1990 Guide by ASTM.

Table 3: ASTM D-19 Standard Guide for Electronic Grade Water D5127-90 (1990)

	Type E-I	Type E-II	Type E-III	Type E IV
Resistivity, megohm-cm minimum,	18 (95% of time) no less than 17	17.5 (90% of time) no less than 16	12	0.5
SiO ₂ (total maximum, µg/L)	5	10	50	1000
Particle count per mL	1	3	10	100
Particle size limit, micron	0.1	0.5	1.0	10
Viable bacteria, maximum	1/1000 mL	10/1000 mL	10/mL	100/mL
Total organic carbon maximum, µg/L	25	50	300	1000
Endotoxins ¹ , EU/mL	0.03	0.25	N/A	N/A
Copper maximum, µg/L	1	1	2	500
Chloride maximum, µg/L	1	1	10	1000
Nickel, mg/L	0.1	1	2	500
Nitrate maximum, mg/L	1	1	5	500
Phosphate maximum, mg/L	1	1	5	500
Potassium maximum, µg/L	2	2	5	500
Sodium maximum, µg/L	0.5	1	5	1000
Sulfate maximum, mg/L	1	1	5	500
Zinc maximum, µg/L	0.5	1	5	500

Note 1 – Substances or by-products usually produced by gram-negative micro-organisms which give a positive test for pyrogens.

Type E-I – Electronic Grade Water. This water will be classified as microelectronic water to be used in the production of devices having line widths below 1.0 micrometer. It is intended that this be the water of ultimate practical purity produced in large volumes and for the most critical uses.

Type E-II – Electronic Grade Water. This water may be classified as microelectronic water to be used in the production of devices having dimensions below 5.0 micrometers. This water should be adequate for producing most high-volume products which have dimensions above 1.0 micrometer and below 5.0 micrometers.

Type E-III – Electronics-Grade Water. This grade of water may be classified as macroelectronic water to be used in the production of devices having dimensions larger than 5.0 micrometers. This grade may be used to produce larger components and some small components not affected by trace amounts of impurities.

Type E-IV – Electronics-Grade Water. Electronics-Grade Water may be classified as electroplating water for noncritical use and other general applications where the water is in constant contact with the atmosphere because of tank storage.

Table 4: Semiconductor Equipment and Materials International (SEMI) Suggested Guidelines for Pure Water for Semiconductor Processing (1989)

This table summarizes the suggested guidelines for pure water utilized in semiconductor processing. This table should not be presented or be interpreted without considering the information of Sections 1-5.

<u>Test Parameter</u>	<u>Attainable</u>	<u>Acceptable</u>	<u>Alert</u>	<u>Critical</u>
Residue, ppm	0.1	0.3	0.3	0.5
Total Organic Carbon (TOC), ppm	0.020	0.050	0.100	0.400
Particulates, counts/liter	500	1000	2500	5000
Bacteria, counts/100 mL	0	6	10	50
Dissolved Silica (SiO ₂) ppb	3	5	10	40
Resistivity, megohm/cm	18.3	17.9	17.5	17
Cations, ppb				
Aluminum (Al)	0.2	2.0	5.0	*
Ammonium (NH ₄)	0.3	0.3	0.5	*
Chromium (Cr)	0.02	0.1	0.5	*
Copper (Cu)	0.002	0.1	0.5	*
Iron (Fe)	0.02	0.1	0.2	*
Manganese (Mn)	0.05	0.5	1.0	*
Potassium (K)	0.1	0.3	1.0	4.0
Sodium (Na)	0.05	0.2	1.0	5.0
Zinc (Zn)	0.02	0.1	0.5	*
Anions, ppb				
Bromide (Br)	0.1	0.1	0.3	*
Chlorine (Cl)	0.05	0.2	0.8	*
Nitrite (NO ₂)	0.05	0.1	0.3	*
Nitrate (NO ₃)	0.1	0.1	0.5	*
Phosphate (PO ₄)	0.2	0.2	0.3	*
Sulfate (SO ₄)	0.05	0.3	1.0	*

*Values not assignable at this time

1. In using these guidelines, it should be recognized that some values may depend on the testing method and the calibration techniques. Consequently, the progression and interrelation of values may be more meaningful than the absolute values.

7.3 Appendix C: Reagent-Grade Water

**National Committee for Clinical Laboratory Standards
(NCCLS) (1991)**

Characteristics	Reagent Water Specifications		
	Type I	Type II	Type III
Bacterial Content (colony forming units per mL maximum)	(1) 10	10 ³	N/A
pH	NS	NS	5.0-8.0
Resistivity (megohms/cm) @ 25°C	0	1.0	0.1
Silicate (mg/L SiO ₂ -Maximum)	0.05	0.1	1.0
Particulate Matter ⁽²⁾	(2) 0.22 µm Filter	NS	NS
Organics	(2) Activated Carbon	NS	NS

(1) Preferably Type I water should be bacteria-free.

(2) These specifications are process specifications and are not measured by the end user.

NS is not specified.

**Table 5: College of American Pathologists (CAP) Water Standards (1991)
note: NCCLS replaced CAP in 1996**

	<u>I</u>	<u>II</u>	<u>III</u>
Specifications for Conductance (microSiemens/cm)	0.1	0.5	10
Specifications Resistance [megohm/cm, 25°C (77°F)]	10 10.0	2.0 2.0	0.1 0.1
Silica (mg/L)	0.05	0.1	1.0
Heavy Metals (mg/L)	0.01	0.01	0.01
Potassium Permanganate Reduction (minutes)	60	60	60

continued

APPENDIX C

	<u>I</u>	<u>II</u>	<u>III</u>
Sodium (mg/L)	0.1	0.1	0.1
Hardness	negative	negative	negative
Ammonia	0.1	0.1	0.1
Microbiological Content (CFU/mL)	10	10 ³	-
pH [25°C (77°F)]	-	-	5.0
CO ₂ (mg/L)	3	3	3

Table 6: ASTM D-1193 Specifications (1991)

	<u>I</u>	<u>II</u>	<u>III</u>	<u>IV</u>
Conductivity maximum [microSiemens/cm; 25°C (77°F)]	0.056	1.0	0.25	5.0
Maximum Resistivity [megohm/cm; 25°C(77°F)]	18.0	1.0	4.0	0.2
pH	-	-	-	5.0-8.0
Total Silica (µg/L)	3	3	500	no limit
TOC (ppb)	100	50	200	no limit
Sodium (ppb)	1	5	10	50
Chloride (ppb)	1	5	10	50
Endotoxin Units (EU)	<0.03	0.25	N/A	-
Maximum Heterotrophic Bacteria Count	A 10/1000 mL	B 10/100 mL	C 100/10 mL	

These specifications cover requirements for water suitable for use in chemical analysis and physical testing. The choice of the various grades may be designated by the method or by the investigator.

N/A = not applicable

7.4 Appendix D: USP 23 WFI and Purified Water Standards

USP23 water monographs (effective 15 November 96)

Water for Injection

Water for Injection (WFI) is water purified by distillation or by reverse osmosis. It contains no added substance.

Note – WFI is intended for use as solvent for the preparation of parenteral solutions (i.e., pharmaceutical solutions injected into the body). Where used for the preparation of parenteral solutions subject to final sterilization, use suitable means to minimize microbial growth, or first render the WFI sterile and thereafter protect it from microbial contamination. For parenteral solutions that are prepared under aseptic conditions and are not sterilized by appropriate filtration or in the final container, first render the WFI sterile and thereafter, protect it from microbial contamination.

Packaging and Storage – Where packaged, preserve in tight containers. Where packaged, may be stored at a temperature below or above the range in which microbial growth occurs.

Reference Standard (RS) – *USP Endotoxin Reference Standard.*

Bacterial Endotoxins – When tested as directed under *Bacterial Endotoxins Test* (85), it contains not more than 0.25 USP Endotoxin Unit per mL.

Other Requirements – WFI meets the requirements of the tests under *Purified Water*.

Purified Water

Purified Water is water obtained by distillation, ion-exchange treatment, reverse osmosis, or other suitable process. It is prepared from water complying with the regulations of the federal Environmental Protection Agency (EPA) with respect to drinking water. It contains no added substance.

Note – Purified Water is intended for use as an ingredient in the

preparation of compendial dosage forms. Where used for sterile dosage forms other than for parenteral administration, process the article to meet the requirements under Sterility Tests (71), or first render the Purified Water sterile and thereafter protect it from microbial contamination. Do not use Purified Water in preparations intended for parenteral administration. For such purposes use WFI, Bacteriostatic WFI, or Sterile WFI.

Packaging and Storage – Where packaged, preserve in tight containers.

Labeling – Where packaged, label it to indicate the method of preparation.

pH <791> – between 5.0 and 7.0 determined potentiometrically in a solution prepared by the addition of 0.30 mL of saturated potassium chloride solution to 100 mL of test specimen.

Oxidizable Substances – To 100 mL add 10 mL of 2 N sulfuric acid, and heat to boiling. Add 0.1 mL of 0.1 N potassium permanganate, and boil for 10 minutes. The pink color does not completely disappear, or use test for total organic carbon.

USP 23 requires incoming feedwater to meet US EPA National Drinking Water Regulations.

	USP Purified Water	WFI
pH	5.0-7.0	5.0-7.0
Conductivity Specifications: refer to charts		
TOC	500 ppb	500 ppb**
Bacteria	100 CFU/mL*	10 CFU/100 mL*
Endotoxins	–	0.25 EU/mL

*Guideline only

**or oxidizable substances test

continued

USP 23 (continued)

Stage 1 – Temperature and Conductivity Requirements
(for nontemperature-compensated conductivity measurements only)

°C Temperature	°F Temperature	Conductivity Requirement ($\mu\text{S}/\text{cm}$)*
0	32	0.6
5	41	0.8
10	50	0.9
15	59	1.0
20	68	1.1
25	77	1.3
30	86	1.4
35	95	1.5
40	104	1.7
45	113	1.8
50	122	1.9
55	131	2.1
60	140	2.2
65	149	2.4
70	158	2.5
75	167	2.7
80	176	2.7
85	185	2.7
90	194	2.7
95	203	2.9
100	212	3.1

* $\mu\text{S}/\text{cm}$ (microSiemens per centimeter) = $\mu\text{mho}/\text{cm}$ = reciprocal of megohm-cm.

Stage 1

1. Determine the temperature of the water and the conductivity of the water using a nontemperature-compensated conductivity reading. The measurement may be performed in a suitable container or as an on-line measurement.
2. Using the Stage 1 – Temperature and Conductivity Requirements table, find the temperature value that is not greater than the measured temperature. The corresponding conductivity value is the limit at that temperature.
3. If the measured conductivity is not greater than the table value, the water meets the requirements of the test for conductivity. If the conductivity is higher than the table value, proceed with Stage 2.

USP 23 (continued)**Stage 2**

4. Transfer a sufficient amount of water (100 mL or more) to a suitable container, and stir the test specimen. Adjust the temperature, if necessary, and, while maintaining it at 25°C (77°KF) $\pm 1^{\circ}\text{C}$, begin vigorously agitating the test specimen while periodically observing the conductivity. When the change in conductivity (due to uptake of atmospheric carbon dioxide) is less than a net of $0.1\ \mu\text{S}/\text{cm}$ per five minutes, note the conductivity.

5. If the conductivity is not greater than $2.1\ \mu\text{S}/\text{cm}$, the water meets the requirements of the test for conductivity. If the conductivity is greater than $2.1\ \mu\text{S}/\text{cm}$, proceed with Stage 3.

Stage 3

6. Perform this test within approximately 5 minutes of the conductivity determination in Step 5, while maintaining the sample temperature at 25°C (77°F) $\pm 1^{\circ}\text{C}$. Add a saturated potassium chloride solution to the same water sample (0.3 mL per 100 mL of the test specimen), and determine the pH, to the nearest 0.1 pH unit, as directed under *pH <791>*.

7. Referring to the Stage 3 – pH and Conductivity Requirements table, determine the conductivity limit at the measured pH value. If the measured conductivity in Step 4 is not greater than the conductivity requirements for the pH determined in Step 6, the water meets the requirements of the test for conductivity. If either the measured conductivity is greater than this value or the pH is outside of the range of 5.0 to 7.0, the water does not meet the requirements of the test for conductivity.

continued

USP 23 (continued)

Stage 3 – pH and Conductivity Requirements
(for atmosphere and temperature equilibrated samples only)

pH	Conductivity Requirement ($\mu\text{S}/\text{cm}$)*
5.0	4.7
5.1	4.1
5.2	3.6
5.3	3.3
5.4	3.0
5.5	2.8
5.6	2.6
5.7	2.5
5.8	2.4
5.9	2.4
6.0	2.4
6.1	2.4
6.2	2.4
6.3	2.3
6.4	2.3
6.5	2.2
6.6	2.1
6.7	2.7
6.8	3.1
6.9	3.8
7.0	4.6

* $\mu\text{S}/\text{cm}$ (microSiemens per centimeter) = $\mu\text{mho}/\text{cm}$ = reciprocal of megohm-cm

7.5 Appendix E: Metric Conversions
Volume (metric and U.S. liquid measures)

From/To	cm³	liter	m³	in³	ft³	yd³	fl oz	gal	bbl (oil)	bbl (liq)
cm ³	1	0.001	1x10 ⁻⁶	0.0610 ²	3.53x10 ⁻⁵	1.31x10 ⁻⁵	0.03381	2.64x10 ⁻⁴	6.29x10 ⁻⁵	8.39x10 ⁻⁶
liter	1000	1	0.001	61.02	0.03532	0.00131	33.81	0.2642	0.00629	0.00839
m ³	1x10 ⁶	1000	1	6.10x10 ⁴	35.31	1.308	3.38x10 ⁴	264.2	6.290	8.386
in ³	16.39	0.01639	1.64x10 ⁻⁵	1	5.79x10 ⁻⁴	2.14x10 ⁻⁵	0.5541	0.00433	1.03x10 ⁻⁴	1.37x10 ⁻⁴
ft ³	2.83x10 ⁴	28.32	0.02832	1728	1	0.03704	957.5	7.481	0.1781	0.2375
yd ³	7.65x10 ⁵	764.5	0.7646	4.67x10 ⁴	27	1	2.59x10 ⁴	202.0	4.809	6.412
fl oz	29.57	0.02957	2.96x10 ⁻⁵	1.805	0.00104	3.87x10 ⁻⁵	1	0.00781	1.86x10 ⁻⁴	2.48x10 ⁻⁴
fl pt	473.2	0.4732	4.73x10 ⁻⁴	28.88	0.01671	6.19x10 ⁻⁴	16	0.1250	0.00298	0.00397
fl qt	946.4	0.9463	9.46x10 ⁻⁴	57.75	0.03342	0.00124	32	0.2500	0.00595	0.00794
gal	3785	3.785	0.00379	231.0	0.1337	0.00495	128	1	0.02381	0.03175
bbl (oil)	1.59x10 ⁵	159.0	0.1590	9702	5.615	0.2079	5376	42	1	1.333
bbl (liq)	1.19x10 ⁵	119.2	0.1192	7276	4.211	0.1560	4032	31.5	0.7500	1



7.6 Appendix F: Silt Density Index (SDI)

The American Society for Testing and Materials (ASTM) Committee on Water has recommended the Silt Density Index (SDI) test or “microporous membrane pluggage test” as a method of indicating the quantity of particulate matter in a water supply. This method is based on determining the rate of pluggage when water is passed through a 0.45-micron membrane filter at a constant applied pressure. The SDI is a nondimensional number calculated from the rate of pluggage. Several reverse osmosis companies use SDI as a means of correlating the maximum level of suspended solids allowable in the feedwater to their systems in order to maintain membrane performance warranties. Some companies require daily measurement and reporting of SDI. Many specifications and warranties for spiral-wound elements have called for SDI values of less than four.

RECOMMENDATIONS

1. Reverse osmosis water purification systems should use 5-micron cartridge filters in order to reduce the SDI level of the feedwater. If other cartridge sizes are used, the SDI before and after the filter should be measured.
2. Feedwater SDI levels of less than 10 are recommended for water purification systems to minimize membrane fouling and extend required cleaning intervals to two weeks or longer. If water with higher SDI levels is used, more frequent cleaning should be anticipated.
3. Where SDI levels following cartridge filters are greater than 10-15, or where frequency of cartridge filter change-outs is too high, backwashable filters or other suitable pre-treatment should be used to reduce the loading on the cartridge filters.

PROCEDURE AND DISCUSSION

The results and conclusions reported above are based on testing conducted over the last 15 years. The test equipment consists of a ball valve, a pressure regulator and pressure gauge followed by a filter holder which accepts a 47-mm diameter filter disc. The water supply to be tested is connected to this apparatus and the pressure regulator is adjusted to provide a constant pressure of 30 psig (2.1 bar) at the filter holder. A 0.45-micron filter disc is placed in

continued

SDI (continued)

the holder and sealed with an O-ring. The inlet valve is opened and the time to collect a 500 mL sample (t_i) is measured as soon as there is a constant flow from the filter holder. Flow through the filter is continued for an elapsed time (T) of up to 15 minutes. At the end of this period, the time required to collect a second 500mL sample (t_f) is measured. For accurate measurements, t_f should be no more than four times the value of t_i . If higher than this, the elapsed time (T) between readings should be reduced. Changes in the procedure such as sample amounts and times may be considered for very high SDI values. The Silt Density Index is calculated as follows:

$$SDI = \frac{\left(1 - \frac{t_i}{t_f}\right)}{T} 100$$

At the end of the test, the membrane filter should be saved for future reference or for analysis of the deposit to determine what material has caused fouling. It should be evident on the 0.45-micron filter that flow has passed through the entire filter surface area; this may be a problem at low flow rates.

There are several limitations which affect the ability to correlate this test directly to fouling and performance of a reverse osmosis system:

1. In this apparatus, all flow goes through the membrane filter, leaving as a deposit all suspended solids greater than 0.45 microns. In reverse osmosis, there is a parallel flow across the membrane surface to help carry away suspended solids.
2. The pore size for the membrane used in this test is 0.45 microns while the pore size is less than 0.002 microns for a reverse osmosis membrane.
3. This test does not take into account the effect of concentration in a reverse osmosis system. Fouling is sometimes caused by concentration and precipitation during processing rather than by suspended solids present in the feedwater.

Despite these limitations there does appear to be a general correlation between SDI value and fouling. Osmonics has been evaluating this test more extensively, and will report additional results and conclusions as this information becomes available.

7.7 Appendix G

Langelier Stability Indexes (LSI)

CaCO₃ SATURATION INDEX (LANGELIER INDEX)

(Based on the Langelier Formula: Larson-Buswell:

Residue - Temperature Adjustments: Arranged by Nordell)

- $pH_s = (9.30 + A + B) - (C + D)$
(Note: Values of A, B, C & D are obtained from tables A, B, C & D)
- Saturation Index = $pH - pH_s$
If index is 0, water is in chemical balance.
If index is a plus quantity, scale forming tendencies are indicated.
If index is a minus quantity, corrosive tendencies are indicated.

Example: To find the saturation index at 124°F of water which has the following characteristics: Total solids-400 ppm; calcium hardness as CaCO₃-240 ppm; alkalinity as CaCO₃-196 ppm; and pH of 7.2. Then:
Total solids 400 ppm = 0.16 (from table A)
Temperature 124°F. = 1.53 (from table B)
Calcium hardness as CaCO₃ 240 ppm = 1.98 (from lower table C)
Alkalinity as CaCO₃ 196 ppm = 2.29 (from upper table D)
Substituting: $pH_s = (9.30 + 0.16 + 1.53) - (1.98 + 2.29) = 6.72$ (or 6.7)
Saturation Index = $7.2 - 6.7 = +0.5$

Table A
Total Solids in ppm

50	.07
75	.08
100	.10
150	.11
200	.13
300	.14
400	.16
600	.18
800	.19
1000	.20
2000	.23
3000	.25
4000	.26
5000	.27
6000	.28

Table B
Temperature in degrees Fahrenheit

		UNITS				
		0	2	4	6	8
TENS	30		2.60	2.57	2.54	2.51
	40	2.48	2.45	2.43	2.40	2.37
	50	2.34	2.31	2.28	2.25	2.22
	60	2.20	2.17	2.14	2.11	2.09
	70	2.06	2.04	2.03	2.00	1.97
	80	1.95	1.92	1.90	1.88	1.86
	90	1.84	1.82	1.80	1.78	1.76
	100	1.74	1.72	1.71	1.69	1.67
	110	1.65	1.64	1.62	1.60	1.58
	120	1.57	1.55	1.53	1.61	1.50
	130	1.48	1.46	1.44	1.43	1.41
140	1.40	1.38	1.37	1.35	1.34	
150	1.32	1.31	1.29	1.28	1.27	
160	1.26	1.24	1.23	1.22	1.21	
170	1.19	1.18	1.17	1.16		

Table C
Calcium hardness expressed as ppm CaCO₃
(For 3 to 209 ppm CaCO₃ use upper table)
(For 210 to 990 ppm CaCO₃ use lower table)

Table D
Alkalinity expressed as ppm CaCO₃
(For 1 to 209 ppm CaCO₃ use upper table)
(For 210 to 990 ppm CaCO₃ use lower table)

		UNITS									
		0	1	2	3	4	5	6	7	8	9
TENS	0				0.08	0.20	0.30	0.38	0.45	0.51	0.56
	10	0.60	0.64	0.68	0.72	0.75	0.78	0.81	0.83	0.86	0.88
	20	0.90	0.92	0.94	0.96	0.98	1.00	1.02	1.03	1.05	1.06
	30	1.08	1.09	1.11	1.12	1.13	1.15	1.16	1.17	1.18	1.19
	40	1.20	1.21	1.23	1.24	1.25	1.26	1.26	1.27	1.28	1.29
	50	1.30	1.31	1.32	1.33	1.34	1.34	1.35	1.36	1.37	1.37
	60	1.38	1.39	1.39	1.40	1.41	1.42	1.42	1.43	1.43	1.44
	70	1.45	1.45	1.46	1.47	1.47	1.48	1.48	1.49	1.49	1.50
	80	1.51	1.51	1.52	1.52	1.53	1.53	1.54	1.54	1.55	1.55
	90	1.56	1.56	1.57	1.57	1.58	1.58	1.58	1.59	1.59	1.60
	100	1.60	1.61	1.61	1.61	1.62	1.62	1.63	1.63	1.64	1.64
	110	1.64	1.65	1.65	1.66	1.66	1.66	1.67	1.67	1.67	1.68
	120	1.68	1.68	1.69	1.69	1.70	1.70	1.70	1.71	1.71	1.71
	130	1.72	1.72	1.72	1.73	1.73	1.73	1.74	1.74	1.74	1.75
	140	1.75	1.75	1.75	1.76	1.76	1.76	1.77	1.77	1.77	1.78
	150	1.78	1.78	1.78	1.79	1.79	1.79	1.80	1.80	1.80	1.80
	160	1.81	1.81	1.81	1.81	1.82	1.82	1.82	1.82	1.83	1.83
	170	1.83	1.84	1.84	1.84	1.84	1.85	1.85	1.85	1.85	1.85
	180	1.86	1.86	1.86	1.86	1.87	1.87	1.87	1.87	1.88	1.88
	190	1.88	1.88	1.89	1.89	1.89	1.89	1.89	1.90	1.90	1.90
	200	1.90	1.91	1.91	1.91	1.91	1.91	1.92	1.92	1.92	1.92

		UNITS									
		0	1	2	3	4	5	6	7	8	9
TENS	0	0.00	0.30	0.48	0.60	0.70	0.78	0.85	0.90	0.95	
	10	1.00	1.04	1.08	1.11	1.15	1.18	1.20	1.23	1.26	1.29
	20	1.30	1.32	1.34	1.36	1.38	1.40	1.42	1.43	1.45	1.46
	30	1.48	1.49	1.51	1.52	1.53	1.54	1.56	1.57	1.58	1.59
	40	1.60	1.61	1.62	1.63	1.64	1.65	1.66	1.67	1.68	1.69
	50	1.70	1.71	1.72	1.72	1.73	1.74	1.75	1.76	1.76	1.77
	60	1.78	1.79	1.79	1.80	1.81	1.81	1.82	1.83	1.83	1.84
	70	1.85	1.85	1.86	1.86	1.87	1.88	1.88	1.89	1.89	1.90
	80	1.90	1.91	1.91	1.92	1.92	1.93	1.93	1.94	1.94	1.95
	90	1.95	1.96	1.96	1.97	1.97	1.98	1.98	1.99	1.99	2.00
	100	2.00	2.00	2.01	2.01	2.02	2.02	2.03	2.03	2.03	2.04
	110	2.04	2.05	2.05	2.05	2.06	2.06	2.06	2.07	2.07	2.08
	120	2.08	2.08	2.09	2.09	2.09	2.10	2.10	2.10	2.11	2.11
	130	2.11	2.12	2.12	2.12	2.13	2.13	2.13	2.14	2.14	2.14
	140	2.15	2.15	2.15	2.16	2.16	2.16	2.16	2.17	2.17	2.17
	150	2.18	2.18	2.18	2.18	2.19	2.19	2.19	2.20	2.20	2.20
	160	2.20	2.21	2.21	2.21	2.21	2.22	2.22	2.23	2.23	2.23
	170	2.23	2.23	2.23	2.24	2.24	2.24	2.24	2.25	2.25	2.25
	180	2.26	2.26	2.26	2.26	2.26	2.27	2.27	2.27	2.27	2.28
	190	2.28	2.28	2.28	2.29	2.29	2.29	2.29	2.29	2.30	2.30
	200	2.30	2.30	2.30	2.31	2.31	2.31	2.31	2.32	2.32	2.32

		TENS									
		0	10	20	30	40	50	60	70	80	90
HUNDREDS	200		1.92	1.94	1.96	1.98	2.00	2.02	2.03	2.05	2.06
	300	2.08	2.09	2.11	2.12	2.13	2.15	2.16	2.17	2.18	2.19
	400	2.20	2.21	2.23	2.24	2.25	2.26	2.26	2.27	2.28	2.29
	500	2.30	2.31	2.32	2.33	2.34	2.34	2.35	2.36	2.37	2.37
	600	2.38	2.39	2.39	2.40	2.41	2.42	2.42	2.43	2.43	2.44
	700	2.45	2.45	2.46	2.47	2.47	2.48	2.48	2.49	2.49	2.50
	800	2.51	2.51	2.52	2.52	2.53	2.53	2.54	2.54	2.55	2.55
	900	2.56	2.56	2.57	2.57	2.58	2.58	2.58	2.59	2.59	2.60

		TENS									
		0	10	20	30	40	50	60	70	80	90
HUNDREDS	200		2.32	2.34	2.36	2.38	2.40	2.42	2.43	2.45	2.46
	300	2.48	2.49	2.51	2.52	2.53	2.54	2.56	2.57	2.58	2.59
	400	2.60	2.61	2.62	2.63	2.64	2.65	2.66	2.67	2.68	2.69
	500	2.70	2.71	2.72	2.72	2.73	2.74	2.75	2.76	2.76	2.77
	600	2.78	2.79	2.79	2.80	2.81	2.81	2.82	2.83	2.83	2.84
	700	2.85	2.85	2.86	2.86	2.87	2.88	2.88	2.89	2.89	2.90
	800	2.90	2.91	2.91	2.92	2.92	2.93	2.93	2.94	2.94	2.95
	900	2.95	2.96	2.96	2.97	2.97	2.98	2.98	2.99	2.99	3.00

RYZNAR STABILITY INDEX

The Ryznar Index is a method of quantifying the scale forming or corrosive effect of water. It is based upon the pH of the water and the water's pH of saturation. The pH of saturation, "pH_s," is that pH at which a water cannot hold additional calcium in solution. The Ryznar Index equation is: $R1 = 2 \text{ pH}_s - \text{pH}$. Ryznar Index values above 6 are progressively corrosive; values below 6 are progressively scale forming.

Nomograph for Determining Langelier or Ryznar Indexes

NEED: total solids, calcium hardness, alkalinity, temperature and pH

- DIRECTIONS:
1. Extend line from Ts to Ca and mark on T-1.
 2. Extend line from Alkaline to t line and mark T-2.
 3. Connect transfer line T-1 and T-2 at the marks.
 4. Read value on pH_s scale and extend line from this value to the pH_a scale. Read values on L and R.
 5. Langelier Index: positive – scale forming
Ryznar Stability Index: below 6.5 – scaling;
above 6.5 – corrosive

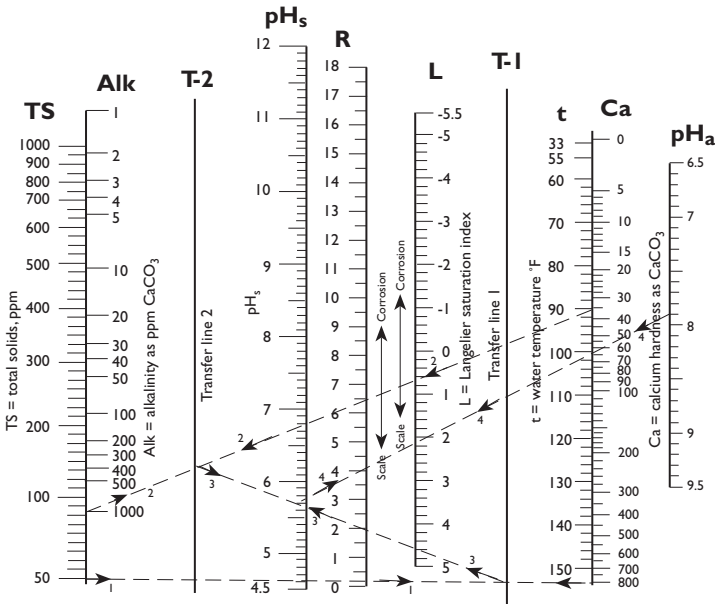

Nomograph simultaneously determines Langelier Saturation Index and Ryznar Stability Index when total solids, calcium hardness, alkalinity, temperature, and pH of water are known.

7.8 Appendix H

Effect of Bicarbonate Alkalinity and CO₂ on pH

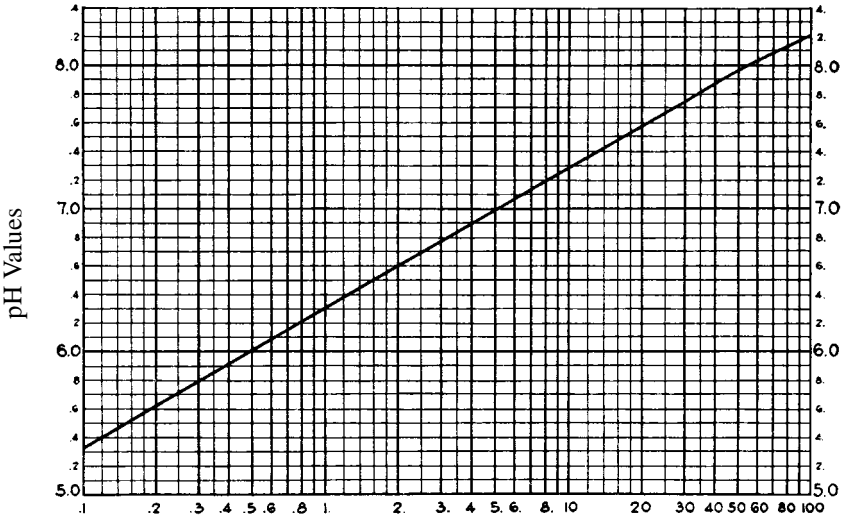

$$\text{Ratio} = \frac{\text{Methyl Orange Alkalinity (Expressed as ppm CaCO}_3\text{)}}{\text{Free CO}_2 \text{ (Expressed as ppm CO}_2\text{)}}$$

Effect of Mineral Acidity on pH

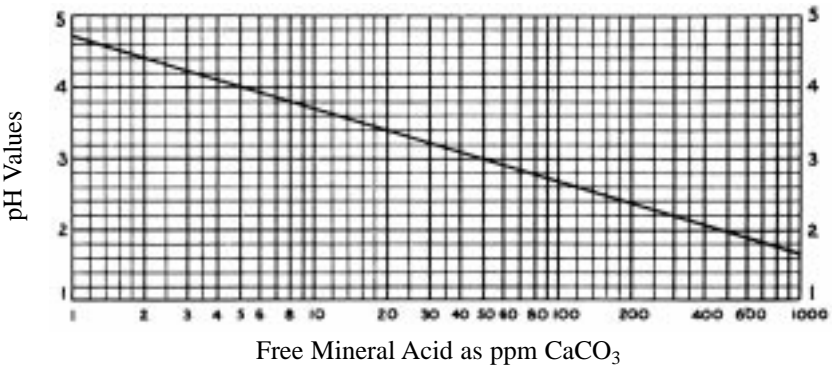

Effect of Carbonate and Bicarbonate Alkalinity on pH

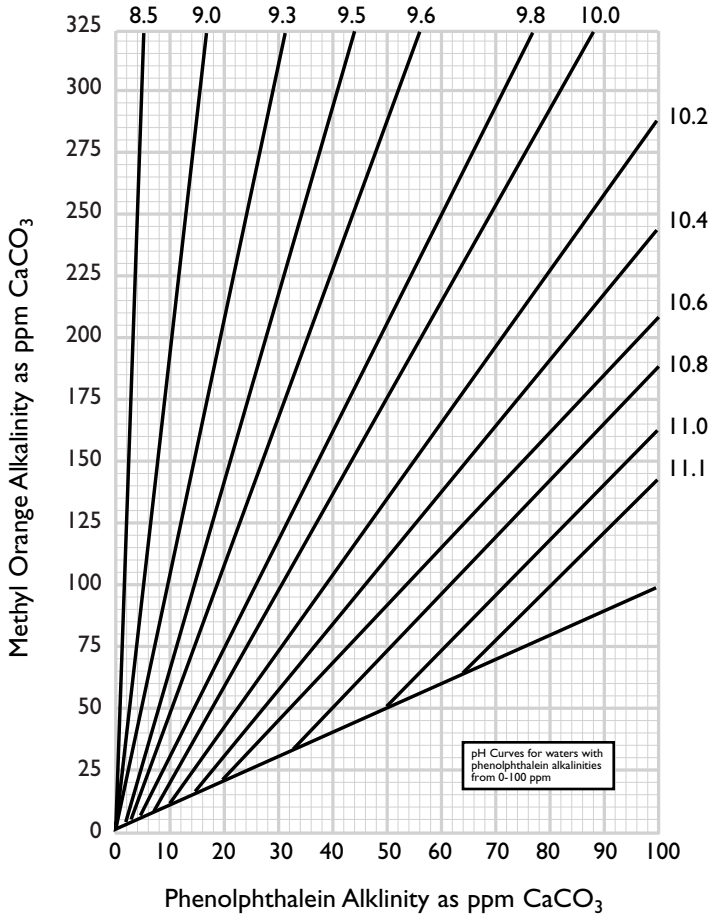

Note: pH value will also depend on temperature of water. Chart above is based on temperature of 20 to 25°C. As water temperature decreases, the pH value for any given combination of alkalinity forms will increase slightly above the value indicated on the chart. For example, at 5°C, actual pH will be about 0.2 units higher in 8.5 to 9.0 pH range; about 0.3 units higher in 9.0 to 10.0 pH range; and above pH 10 actual pH will be 0.4 to 0.6 pH units higher than indicated by chart.

7.9 Appendix I: Sieve Mesh Conversion Table

Screen Equivalents

Sieve No.	U.S. Standard		Meshes per Inch	Tyler Standard		Meshes per Inch	British Standard	
	Opening			Opening			Opening	
	mm	Inches		mm	Inches		mm	Inches
12	1.68	0.0661	10	1.65	0.065	10	1.68	0.0660
14	1.41	0.0555	12	1.40	0.055	12	1.40	0.0553
16	1.19	0.0469	14	1.17	0.046	14	1.20	0.0474
18	1.00	0.0394	16	0.991	0.039	16	1.00	0.0395
20	0.84	0.0331	20	0.833	0.0328	18	0.853	0.0336
25	0.71	0.0280	24	0.701	0.0276	22	0.699	0.0275
30	0.59	0.0232	28	0.589	0.0232	25	0.599	0.0236
35	0.50	0.0197	32	0.495	0.0195	30	0.500	0.0197
40	0.42	0.0165	35	0.417	0.0164	36	0.422	0.0166
45	0.35	0.0138	42	0.351	0.0138	44	0.353	0.0139
50	0.297	0.0117	48	0.295	0.0116	52	0.295	0.0116
60	0.250	0.0098	60	0.246	0.0097	60	0.251	0.0099
70	0.210	0.0083	65	0.208	0.0082	72	0.211	0.0083
80	0.177	0.0070	80	0.175	0.0069	85	0.178	0.007
100	0.149	0.0059	100	0.147	0.0058	100	0.152	0.006
200	0.074	0.0029	200	0.074	0.0029	200	0.076	0.003
325	0.044	0.0017	325	0.043	0.0017	240	0.066	0.0026

8.0 GLOSSARY OF WATER PURIFICATION TERMS

This Glossary is not meant to be all-encompassing but instead contains terms used in the different forms of purification and separation familiar to Osmonics.

AAMI: Association for the Advancement of Medical Instrumentation – sets the standards for kidney dialysis-grade water (See page 70).

absolute: When referring to filters is used in reference to the micron rating of cartridge or disc filters, indicating that all particles larger than a specified size will be trapped within or on the filter and will not pass through (See page 39).

absorb: The process by which a liquid penetrates the solid structure of the absorbent's fibers or particles, which then swell in size to accommodate the liquid.

absorption: The process of taking up a substance into the physical structure of a liquid or solid by physical or chemical action, but without chemical reaction.

ACFM: ACFM means actual cubic feet per minute. In air and gas streams the ACFM is the actual flow. When corrected for pressure and temperature, ACFM can be correlated to SCFM (standard cubic feet per minute).

acid rain: Rainfall below the natural pH range, caused by contact with atmospheric pollutants such as nitric and sulfuric oxides and carbon monoxide.

activated carbon: Granulated activated carbon used to remove tastes, odor, chlorine, chloramines, and some organics from water (See page 36).

activated clay: An adsorbent clay that removes color, odor, free fatty acids, etc., from oils and tallows.

admix: Medium that is added directly into the batch tank of pre-coat to create a permeable filter cake. Usually used in place of body feed.

adsorb: The act of selectively attracting and holding a gas, vapor, liquid, chemical or colloid onto the surface of a solid.

adsorption: The process by which molecules, colloids, or particles adhere to the surfaces by physical action but without chemical reaction.

aeration: The process of adding air to a water supply for the purpose of oxidizing or mixing.

aerosols: Liquid droplets or solid particles dispersed in air or gases, of fine enough particle size (0.01 to 100 μm) to remain so dispersed for a period of time. Generally removed by coalescing filters.

agglomerate: The process of bringing together smaller divisions into a larger mass.

alkalinity: Capacity for neutralizing acid, usually due to presence of bicarbonate or carbonate ions. Hydroxide, borate, silicate, or phosphate ions may contribute to alkalinity in treated waters (See page 25).

angstrom: A unit of length equaling 10^{-10} meters, 10^{-4} microns, 10^{-8} centimeters, and 4×10^{-9} inches. The symbol is Å.

anion: Negatively-charged ion in a solution (See pages 26 & 44).

antimicrobial: An additive, material, fluid or chemical that inhibits and kills the growth of micro-organisms on contact.

aquifer: Natural, underground porous formation where mineral-bearing water flows or is stored. Source of well water (See page 13).

ASAIO: American Society for Artificial Internal Organs (See page 70).

asbestos: A fibrous silicate material, chiefly calcium magnesium silicate; a noncombustible, nonconducting, and chemical-resistant material; a known lung carcinogen.

ASME code: Used in relation to filter vessels. ASME=American Society of Mechanical Engineers, Boiler and Pressure Vessels. Sections VIII and X apply to pressure vessels.

ASTM: American Society for Testing and Materials – sets the standards for laboratory and electronics water (See page 89).

atmosphere: A unit measurement of pressure. The air pressure at sea level: 14.7 psi. (1 atm = 14.7 psi).

backwash: Reversal of a solution's flow through a filtration system. Often used as a cleansing mechanism in sand and dual-media filters (See page 34).

bacteria: Any of a class of microscopic single-celled organisms reproducing by fission or by spores. Characterized by round, rod-like spiral or filamentous bodies, often aggregated into colonies or mobile by means of flagella. Widely dispersed in soil, water, organic matter, and the bodies of plants and animals. Either autotrophic (self-sustaining, self-generative), saprophytic (derives nutrition from nonliving organic material already present in the environment), or parasitic (deriving nutrition from another living organism). Often symbiotic in man, but sometimes pathogenic (See page 13).

bactericide: Agent capable of destroying bacteria.

bacteriostat: Substance that inhibits bacterial growth and metabolism but does not necessarily kill the cell.

baffle: A plate or deflector to provide flow distribution in a filter housing. Primary functions are to provide uniform flow and to prevent erosion of pre-coat or bed and setting of body feed.

bar: Designation of pressure units. 1 bar = psi ÷ 14.5.

beta rating (β) of a cartridge or element: The filtration ratio (β) is the number of particles size x μm and larger in the feed divided by the number of particles in the filtrate.

binders: In reference to cartridge filters, chemicals used to hold or "bind" short fibers together in a filter.

blind spots: Any place on a filter septum where liquid cannot flow through due to blinding or plugging.

blinding: In depth and surface filtration, a buildup of particulates on or within the filter, preventing fluid flow through the filter at normal pressures (See page 41).

blowdown: In reference to boiler technology, the purge from the system of a small portion of concentrated boiler water in order to maintain the level of dissolved and suspended solids in the system below the maximum (See page 82).

BOD: (Biochemical Oxygen Demand) – a measure of the amount of oxygen required for the biochemical degradation of organic material in a water sample (See page 22).

body feed: The pre-coat medium that is continuously added to the filter while it is on stream. Its purpose is to create a permeable filter cake.

bottled water: Commercial products sold in containers as pure water for drinking and domestic use (See page 94).

bridging: The act of particles forming an arch over the openings on a septum. Also filter cakes that have grown to a size where they actually touch each other in the filter.

bubble: The differential gas pressure that when applied to a filter element submerged in the test fluid causes the first steady emission of gas (air) from the filter element being tested. This is a means of verifying the micrometer rating of the test element.

burst: The ability of the filter medium to resist disruption by pressure applied in the direction of normal flow.

cake: The accumulation of solids on the medium, on the surface of the pre-coat or on the septum.

cake space: The volumetric space available in a filter to support the formation of a cake.

candle turbidimeter: A device principally used to measure high turbidity water with results expressed in Jackson Turbidity Units (JTU) or Formazine Turbidity Units (FTU). The JTU is measured with light scattering (See page 15).

CAP: College of American Pathologists, which has set water purification standards for laboratory use (See pages 92 and 109).

CAPD: Continuous ambulatory peritoneal dialysis

carbonate hardness: The hardness caused by carbonates and bicarbonates of calcium and magnesium in water. The amount of hardness equivalent to the alkalinity formed and deposited when water is boiled. In boilers, carbonate hardness is readily removed by blowdown (See page 24).

carcinogenic materials: A substance or agent producing or inciting cancer (See page 26).

cartridge filter: A filter device, usually disposable, filtering in the range of 0.1 micron to 100 microns, and usually 2 inches to 4 inches (51 to 102 mm) in diameter and 6 inches to 60 inches (152 to 1524 mm) in length (See page 37).

cation: Positively-charged ion in a solution (See page 44).

caustic soda: Sodium hydroxide (NaOH), commonly known as lye. A commonly-used chemical in water treatment (See page 32).

cellulose: A fibrous material of vegetable origin used as a filter medium.

CFM: Cubic feet per minute

chelating agent: A molecule, usually organic, which is soluble in water and undergoes reactions with metal ions to hold them in solution. A number of naturally-occurring organic materials in water have chelating ability, such as humic acid and lignin. Due to their chelating abilities, some organic materials interfere with water-softening processes (See page 34).

chemical solution feeder: A pump used to meter chemicals such as acid, chlorine or polyphosphate into a feedwater supply.

chloramine: A compound consisting of chlorine and ammonia gas which retains its bactericidal qualities for a longer time than does free chlorine (See page 26).

chlorination: The addition of small amounts of free chlorine, usually 0.2 to 2.0 ppm, to render water bacteriostatic in a water supply (See page 89).

chlorine: Chemical used for its qualities as a bleaching, oxidizing or disinfecting agent in water purification (See page 25).

clarity: The clearness of a liquid as measured by a variety of methods.

cloth: A type of woven filter septum made from natural or synthetic yarns.

coagulant: Chemical added in water and wastewater applications to cause the formation of flocs that adsorb, entrap, or otherwise bring together suspended matter defined as colloidal. Compounds of iron and aluminum are

generally used to form flocs to allow removal of turbidity, bacteria, color, and other finely-divided matter from water and wastewater (See page 30).

coalescing: The separation of mixtures of immiscible fluids (such as oil and water) with different specific gravities. Can occur whenever two or more droplets collide and remain in contact and then become larger by passing through a coalescer. The enlarged drops then separate out of solution more rapidly.

COD: Chemical Oxygen Demand – a measure of the oxygen required to oxidize chemicals contained in a sample (See page 23).

colloid: A substance of very fine particle size, typically between 0.1 and 0.001 microns in diameter suspended in liquid or dispersed in gas. Typically removable only by reverse osmosis, distillation, or ultrafiltration (See page 26).

compaction: In crossflow filtration, the result of applied pressure compressing a reverse osmosis or ultrafiltration membrane which may result in a decline in flux.

compound: Chemical bonding or union of separate elements, ingredients, or parts (See page 21).

compressibility: Degree of physical change in volume when subject to pressure.

concentrate: In crossflow filtration, the portion of a feed stream which does not permeate the medium but retains and is increased in the amount of ions, organics, and suspended particles which are rejected by the medium (See page 53).

concentration: The amount of material contained in a unit volume of fluid; the process of increasing the dissolved material per unit volume (See page 19).

concentration polarization: In crossflow filtration, the formation of a more concentrated gradient of rejected material near the surface of the membrane causing either increased resistance to solvent transport, or an increase in local osmotic pressure, and possibly a change in rejection characteristics of the membrane.

condensate: Water obtained through evaporation and subsequent condensation. Normally the water resulting from condensing plant steam originally generated in a boiler. Water condensed in a water still operation is usually called distillate (See page 28).

conductivity: The property of a substance's (in this case, water) ability to transmit electricity. The inverse of resistivity. Measured by a conductivity meter, and described in microSiemens/cm (See page 18).

contact time: The length of time an absorbant or adsorbant is in contact with a liquid prior to being removed by the filter or to the occurrence of a chemical change.

contaminant: A source of contamination, an impurity. Any substance in water other than H₂O (See page 12).

convoluting: The accordion pleating of filter media to obtain a large effective filtration area in a minimum volume.

crossflow membrane filtration: A separation of the components of a fluid by semipermeable membranes through the application of pressure and parallel flow to the membrane surface. Includes the processes of reverse osmosis, ultrafiltration, nanofiltration, and microfiltration (See page 53).

crypto: An abbreviation for *Cryptosporidium*, a parasite found in water; sometimes found in drinking water, municipal water systems and private wells. It is detrimental to the digestive system, causes diarrhea, cramps and in severe cases even death.

cycle: The length of time a filter is "on-stream" before cleaning is needed. Frequently meant to include cleaning time as well.

dalton: A unit of mass 1/12 the mass of Carbon¹². Named after John Dalton (1766-1844), founder of atomic theory and the first theorist since Democritus (Greek, 5th century BC) to describe matter in terms of small particles (See page 22).

DE: The commonly-used abbreviation for Diatomaceous Earth. Diatomaceous Earth is the fossilized skeletons of minute, prehistoric aquatic plants. Insoluble in water (See page 36).

decarbonation: The process of removing CO₂ from water, typically using contact towers or air scrubbers.

degasification: The process of removing dissolved gasses from water, typically using vacuum or heat.

deionization (DI): Process utilizing specially-manufactured ion exchange resins which remove ionized salts from water. Can theoretically remove 100% of salts. Deionization typically does not remove organics, virus or bacteria, except through “accidental” trapping in the resin and specially-made strong base anion resins which will remove gram-negative bacteria (See page 44).

Delta P: A commonly-used term denoting the pressure drop across a filter.

demineralization: The process of removing minerals from water, usually through deionization, reverse osmosis, or distillation (See page 94).

detergent: A cleansing agent; any of numerous synthetic water-soluble or liquid-organic preparations that are chemically different from soaps but resemble them in the ability to emulsify oils and hold dirt in suspension (See page 28).

differential pressure: The difference in pressure between the upstream and downstream sides of a filter. It can also be the difference in pressure between two points in a system or of a component in such system.

dirt capacity: The weight of a specified artificial contaminant which must be added to the influent to produce a given differential pressure across a filter at specified conditions. Used as an indication of the relative service life.

disinfectant: A fluid or gas used to disinfect filters, demineralized (DI) water systems, pipe, pipelines, systems, vessels, etc.

disinfection: The process of killing pathogenic organisms in a water supply or distribution system by means of heat, chemicals, or UV light (See page 31).

disposable: Quality describing a filter which is intended to be discarded and replaced after each service cycle.

dissolved solids: The residual material remaining from a filtered source after evaporating the solution to a dry state (See page 30).

distillate: The product water from distillation formed by condensing vapors (See page 48).

distillation: The process of condensing steam from boiling water on a cool surface. Most contaminants do not vaporize and therefore do not pass to the distillate. Removes nearly 100% of all impurities (See page 48).

Doctor Blade (knife): A sharp, hard blade that cuts the cake off the surface of a filter. Usually found on a rotary vacuum pre-coat or metal edge-type filter.

effective area: The total area of the medium exposed to flow in a filter element.

efficiency: The ability, expressed as a percent, of a filter to remove a specified artificial contaminant at a given contaminant concentration under specified test conditions.

effluent: The output stream exiting a treatment system.

electrodialysis: Dialysis that is conducted with the aid of an electromotive force applied to electrodes adjacent to both sides of the membrane (See page 52).

element: Any structural member in a filter on which the septum is supported. May be round, rectangular or cylindrical.

end cap: A ported or closed cover for the end of a cartridge, pipe or housing.

endotoxin: A heat-resistant pyrogen, specifically a lipopolysaccharide found in the cell walls of viable and nonviable bacteria (See page 21).

Endotoxin Units (EDU): Unit of measurement for pyrogen levels (See page 22).

EPA: Environmental Protection Agency (USA) – an organization that has set the potable water standards (See page 29).

evaporation: Process in which water passes from a liquid to a vapor state (See page 13).

exhaustion: In water softening or ion exchange, the point where the resin

can no longer exchange additional ions of the type the process was designed for (See page 45).

FDA: U.S. Food and Drug Administration (See page 94).

feed/feedwater: The input solution to a treatment/purification system, including the raw water supply prior to any treatment (See page 16).

filter aid: Any material that assists in the separation of solids from liquids. Usually used on difficult filter applications.

filter cake: The accumulated particles on a filter surface, usually from a slurry mixture, to enhance the filtering characteristics of a filter medium.

filter medium: The permeable material that separates particles from a fluid passing through it.

filter system: The combination of a filter and associated hardware required for the filtration process.

filtrate: Any liquid that has passed through the filter medium. Sometimes erroneously called effluent. Also known as the clarified effluent from a filter (See page 39).

filtration: The process by which solid particles are separated from a liquid by passing the liquid through a permeable material. Also, the physical or mechanical process of separating insoluble particulate matter from a fluid, such as air or liquid, by passing the fluid through a filter medium that will not let the particulates through (See page 35).

filtration rate: The volume of liquid that passes through a given area in a specified time. Usually expressed as gallons per square foot per minute (or hour).

floc: Coagulated groupings of formerly suspended particles which then settle by gravity (See page 30).

flocculant: Chemical(s) which, when added to water, cause suspended particles to coagulate into larger groupings (flocs) which then settle by gravity (See page 27).

flocculation: The process of agglomerating particles into larger groupings called flocs, which then settle by gravity.

flow fatigue resistance: The ability of a filter element to resist structural failure due to flexing caused by differential pressures.

fluid compatibility: The suitability of filtration medium and seal materials for service with the fluid involved.

flux: In crossflow filtration, the unit membrane throughput, usually expressed in volume per unit time per area, such as gallons per day per ft² or liters per hour per m².

fouling: In crossflow filtration, the reduction of flux that is attributed to a buildup of solids on the surface of the membrane (See pages 30 and 52).

frazier: A test to measure the air permeability of filter septums. Usually expressed in CFM of air at a Delta P of 1/2-inch WC (water column).

FTU: Formazine Turbidity Units – a measure of turbidity, by a nephelometer (See page 15).

Fuller's Earth: A sorptive clay, also called Attapulgus Clay (Attapulgite), Bentonite (Montmorillonite) and Kaolin (Kaolinite). Generally used for filtration, acid removal, bleaching, decolorizing, clarifying agents, filter aids, floor adsorbents, animal litter, pesticide carriers, components or noncarbon papers, catalysts, and refining aids. Also removal of surfactants from gasoline, kerosene, diesel and jet fuels. Not to be confused with DE.

gauge: Thickness of steel sheet or wire diameter. The lower the gauge, the thicker the steel or larger the wire diameter. Also a device for measuring thicknesses, pressures, temperatures, etc.

Giardia cyst: A parasite found in water. Very detrimental to the digestive system, causing diarrhea, cramps and in severe cases death.

glassing: A form for silica scaling at high temperatures, usually in high-pressure boilers or stills (See page 26).

gpd: Gallons per day

grains per gallon (gpg): A unit of concentration equal to 17.1 milligrams per liter (17.1 ppm) (See page 24).

GRAS: Materials “Generally Regarded As Safe,” as listed by the FDA.

groundwater: Water confined in permeable sand layers or cavities between rock or clay. All subsurface water (See page 13).

hardness: The concentration of calcium and magnesium salts in water (See page 24).

head: An end closure for the filter case or bowl which contains one or more ports. Also the measurement of pressure in a column of water expressed in feet of liquid depth $\times 0.433 =$ pounds per square inch.

heavy metals: Metals having a high density or specific gravity of approximately 5.0 or higher. The elemental weight is also high. A generic term used to describe contaminants such as cadmium, lead, and mercury. In low concentrations most are toxic to humans. (See page 28).

heel: The liquid left in the filter at the end of a cycle. Also the pre-coat left on an R.V.P.F. (Rotary Vacuum Pre-coat Filter) at the end of its cycle.

hemodialysis: The process of purifying a kidney patient's blood by means of dialysis membranes (See page 70).

hemolysis: Rupturing of red blood cells sometimes occurring during hemodialysis. May be caused by the presence of chloramines in the dialysis water supply (See page 70).

High Efficiency Particulate Absolute (HEPA): A filter which removes from air 99.97% or more monodisperse dioctyl phthalate (DOP) particles having a mean particle diameter of 0.3 μm . Common use: "HEPA filter" high efficiency particulate air filter.

high-purity water: Highly-treated water with attention to microbiological reduction or elimination; the term commonly used in the pharmaceutical industry (See page 66).

housing: A ported chamber with closure, which directs the flow of fluid through the filter element.

humic acid: A water-soluble organic compound composed of decayed vegetable matter which is leached into a water source by runoff. Present in most surface waters. Higher concentrations cause a brownish tint. Difficult to remove except by ultrafiltration or reverse osmosis (See page 29).

hydrocarbon: An organic compound containing only carbon and hydrogen and often occurring in petroleum, natural gas, coal, and bitumens. Most successfully removed from water by coalescing for large volumes or by using activated carbon for small volumes. (See page 29).

hydrogen sulfide: A toxic gas (H_2S) that is detectable by a strong “rotten egg” odor. A common by-product of anaerobic bacteria (See page 28).

hydrologic cycle: The natural cycle of water as it passes through the environment by evaporation, condensation, precipitation, and retention in the oceans or on land (See page 12).

hydrophilic: Water-accepting.

hydrophobic: Water-rejecting.

influent: The fluid entering the filter.

injection: In water treatment, the introduction of a chemical or medium into the process water for the purpose of altering its chemistry or filtering specific compounds (See page 62).

in-line filter: A filter assembly in which the inlet, outlet and filter element axes are in a straight line.

inside-out flow: Fluid flow through a filter element outward from and perpendicular to its longitudinal axis. This is not the normal direction of flow for most filter elements (See outside-in flow).

ion: An atom or molecule which has lost or gained one or more electrons, thereby acquiring a net electric charge (See page 17).

ion exchange: A process in which ions are preferentially based on equilibrium, adsorbed from a solution for equivalently-charged ions attached to small solid structures called resin (See page 27).

JTU: Jackson Turbidity Units – turbidity test units of measurement registered on a candle turbidimeter (See page 15).

LAL: *Limulus* Amoebocyte Lysate – a reagent used in the detection of endotoxin, the pyrogen of greatest concern to the pharmaceutical industry. The LAL reagent is made from the blood of the horseshoe crab, *Limulus polyphemus* (See page 22).

laminar flow: A flow in which rapid random fluctuations are absent, nonturbulent (See page 60).

leaf: Any flat filter element that holds or supports the filter septum.

LSI: Langelier Saturation Index – an expression of a calculation that allows the prediction of calcium carbonate precipitation at a specific condition, temperature, pH, TDS, hardness, and alkalinity.

L-Type filter: A filter assembly in which the inlet and outlet ports are at 90 degrees to each other.

manifold: A set of ports that come together to form a common port.

mean filtration rating: A measurement of the average size of the pores of the filter medium.

media: The material that performs the actual separation of solids from liquids. Sometimes erroneously used to mean septum.

media migration: Release of filtration media particles into the effluent of the filter.

medical device manufacturer: A manufacturer that, according to the FDA, has specific manufacturing and recordkeeping which allows the manufacturer to be certified as a medical device manufacturer. The purpose is to assure physicians and patients that strict controls have been used and that component traceability is assured.

medium: The porous material that performs the actual process of filtration. The plural of this word is “media.”

membrane (polymeric): Highly-engineered polymer film containing controlled distribution of pores. Membranes serve as a barrier permitting the passage of materials only up to a certain size, shape, or character. Membranes are used as the separation mechanism in reverse osmosis, electrodialysis, ultrafiltration, nanofiltration, and microfiltration, as disc filters in laboratories, and as pleated final filter cartridges, particularly in pharmaceutical and electronic applications (See page 32).

mesh: Number of strands in a linear inch of woven filter fabric, usually wire. It is also used as a septum.

mg/L: Milligrams of an element per liter of water; approximately equal to ppm (See page 15).

microfiltration (MF): Filtration designed to remove particles and bacteria in the range of 0.1 to 3 microns in diameter (See pages 53 and 58).

micron: A metric unit of measurement equivalent to 10^{-6} meters, 10^{-4} centimeters. Symbol is μ (See page 16).

mixed-bed: An ion exchange tank consisting of both cation and anion resin mixed together. Provides the most complete deionization of water, up to 18.3 megohm/cm resistivity. Commonly used to polish water already treated by two-bed ion exchange tanks or reverse osmosis (See page 46).

module: A membrane element combined with the membrane element housing.

molecular weight (MW): The sum of the atomic weights of the constituents which make up a molecule. Often used to indicate size when referring to ultrafiltration of saccharide compounds (See dalton and page 22).

molecule: The smallest physical unit of a compound or chemical, composed of one or more atoms, that retains the properties of that substance (See page 65).

multi-pass test: The test used to determine the Beta-ratio of an element. A destructive test.

multifilament: A number of continuous fiber strands that are twisted together to form a yarn; used in weaving filter cloths.

multiple-effect evaporation: Series-operation energy economizer system where heat from the steam generated (evaporated liquid) in the first stage is used to evaporate additional liquid in the second stage (by reducing system pressure), and so on, up to 10 or more effects (See page 49).

nanofiltration (NF): A crossflow membrane separation process which removes particles in the 250 to 1000 molecular weight range, selected salts and most organics; sometimes referred to as a softening membrane process (See page 56).

NCCLS: National Committee for Clinical Laboratory Standards – a committee that has promulgated purified water standards (See Appendix).

nephelometer: A device used to measure mainly low-turbidity water with results expressed in Nephelometric Turbidity Units (NTU) (See page 15).

nominal: With regard to the micron rating of cartridge filters, refers to an approximate size particle, the vast majority of which will not pass through the filter. A small amount of particles this size or larger may pass through the filter (See page 35).

nominal rating: An arbitrary micrometer value indicated by various filter manufacturers.

noncarbonate hardness: Hardness caused by chlorides, sulfates, and nitrates of calcium and magnesium. Evaporation of waters containing these ions makes the water highly corrosive (See page 24).

nonwoven: A filter cloth or paper that is formed of synthetic fibers that are randomly oriented in the media. Usually held together by a binder.

normal flow: The flow of the entire feedwater stream in a single direction directly through the filter medium. The flow is generally “normal,” or perpendicular, to the medium (See page 58).

NTU: Nephelometric Turbidity Units – the result of passing a light beam through a water sample with a nephelometer to quantify low-turbidity water. The NTU is measured by light scattering. (See page 15).

on-stream: Describes when a filter system is producing a filtered product while in operation.

osmosis: The spontaneous flow of water from a less concentrated solution to a more concentrated solution through a semipermeable membrane until energy equilibrium is achieved.

osmotic pressure: A measurement of the potential energy difference between solutions on either side of a semipermeable membrane. A factor in designing reverse osmosis equipment. The applied pressure must first overcome the osmotic pressure inherent in the chemical solution in order to get good purification and flux.

outside-in flow: Fluid flow is through a filter element perpendicular to and toward the axis of the element on most filters today. Exception is the coalescing element which always flows from inside to outside to remove the accumulated water from the fuel stream.

oxidation: Process by which electrons are lost to an oxidizing agent in order to increase a molecule or ion in positive valence (See page 23).

oxidizing filters: Filters that use a catalytic medium such as manganous oxide to oxidize iron and manganese and then filter the impurities from the water after they have been oxidized (See page 36).

ozonator: A device which generates ozone by passing a high-voltage current through a chamber containing air or oxygen. Used as a disinfection system.

ozone (O₃): An unstable, highly reactive state of the oxygen formed by passing air or oxygen through a high-voltage electric charge or strong light source. An excellent oxidizing agent and bactericide. (See pages 34 and 63).

particle filtration (PF): Filtration rated in the range of 1 to 75 microns. Typically handled by cartridge filters.

particulate: Minute, separate pieces of matter (See page 13).

permeable: Allowing some material to pass through.

permeate: That portion of the feed stream which passes through a membrane, leaving behind a more concentrated stream (See pages 52 and 53).

permeator: A hollow fine-fiber membrane element itself consisting of thousands of hollow fibers.

pH: An expression of hydrogen ion concentration; specifically, the negative logarithm of the hydrogen ion concentration. The range is from 0 to 14, with 7 as neutral, 0 to less than 7 as acidic, and 7 to 14 as alkaline (basic) (See pages 13 and 17).

phase: A state of matter, either solid, gaseous, or liquid (See page 29).

polymer: A chemical compound with many repeating structural units

produced by uniting many primary units called monomers.

pore: An opening in a membrane or filter matrix (See page 41).

porous: The ability of certain substances to pass fluids due to an open physical structure (See page 13).

ppb: Parts per billion, commonly considered equivalent to micrograms per liter ($\mu\text{g/L}$) (See page 16).

ppm: Parts per million, commonly considered equivalent to milligrams per liter (mg/L) (See page 15).

ppt: Parts per trillion, commonly considered equivalent to nanograms per liter (ng/L) (See page 49).

precipitate: An insoluble product that is in the solution or liquid mixture (See page 25).

precipitation: The process of producing an insoluble reaction product from a chemical reaction, usually a crystalline compound that grows in size to be settleable (See page 13).

precursors: Compounds such as humic acid which may lead to the creation of other compounds, such as THM (See page 26).

psi: Pounds per square inch (pressure).

psid: Pounds per square inch differential (See page 60).

psig: Pounds per square inch gauge (See page 55).

pyrogen: Any substance capable of producing a fever in mammals. Often an organic substance shed by bacteria during cell growth. Chemically and physically stable, pyrogens are not necessarily destroyed by conditions that kill bacteria (See page 21).

reagent-grade water (ASTM): Water that meets the standards for reagent use promulgated by American Society for Testing and Materials. Four ASTM reagent-grades, I through IV, have been established depending upon intended use. See Appendix for specific quality requirements (See page 110, table 6).

recirculation: a) In crossflow membrane systems, the recycling of a portion of the stream to maintain a desirable flow. b) In water system design, the continuous operation of the transfer pump to keep water flowing through the system above the use rate, to reduce the hazard of bacterial growth. A portion of the water continuously goes back to the break tank (See page 66).

regeneration: The displacement from the ion exchange resin of the ions removed from the process water or waste stream (See page 43).

rejection: In crossflow membrane systems, the process of retaining at the membrane contaminants that are larger than the membrane's pore sizes or are repelled by an electrical charge. In a membrane system, expressed as a percent of the total presence of those contaminants (See page 55).

resins (ion exchange): Specially manufactured polymer beads used in the ion exchange process to remove dissolved salts from water (See page 32).

resistivity: The property of a substance (in this case, water) to resist the flow of electricity; the measurement of that resistance. The inverse of conductivity. Measured by a resistivity monitor and described in megohm-cm (See page 19).

reverse osmosis (RO): The separation of one component of a solution from another component by flowing the feed stream under pressure across a semipermeable membrane. RO concentrates ionized salts, colloids, and organics down to 150 molecular weight in the concentrate stream and provides a purified stream of water. May also be called hyperfiltration (See pages 16 and 55).

saturation: The point at which a solution contains enough of a dissolved solid, liquid, or gas so that no more will dissolve into the solution at a given temperature and pressure (See page 12).

scaling: The buildup of precipitated salts on such surfaces as pipes, tanks and boiler condensate tubes (See page 25).

scavenger: A filter, or element in the bottom of a filter, that recovers the liquid heel that remains in the filter tank at the end of a cycle.

screen: A term commonly used for septum. Also a wire mesh screen used to screen out large-sized particles that would clog a filter cartridge. Usually installed on the suction side of a pump.

SDI: Silt Density Index – test used to measure the level of suspended solids in feedwater for a reverse osmosis system (See page 16).

SEMI: Semiconductor Equipment and Materials International – has set the electronics-grade purified water standards (See page 89 and Appendix).

semipermeable: In membranes, a membrane which allows a solvent such as water to pass through, while rejecting certain dissolved or colloidal substances (See page 52).

sepralator: A spiral-wound membrane element in crossflow membrane systems. Modular and replaceable (See page 59).

septum: A binding wall or membrane.

side seal: The longitudinal seam of the filter medium in a pleated filter element.

solutes: Matter dissolved in a solvent.

sparger: A device to introduce compressed air or gas into a liquid to agitate it or to dissolve the air or gas in this liquid. Spargers are made of porous ceramic or stainless steel in various grades (porosities) to provide a specific-sized “bubble.”

strainer: A coarse filter element (pore size over 40 μm); also a unit that screens out large particles, normally on the suction side of a pump.

suspended solids (SS): Solid organic and inorganic particles that are held in suspension in a solution (See page 16).

TDS: Total Dissolved Solids – See dissolved solids (See page 18).

THM: Trihalogenated Methane Compound – Initiated by contact between free chlorine and certain organics to form materials similar to certain organic solvents. Considered a carcinogen (See page 26).

TOC: Total Organic Carbon – The amount of carbon bound in organic compounds in a water sample as determined by a standard laboratory test. The CO_2 is measured when a water sample is atomized in a combustion chamber (See page 22).

traceability: In medical and pharmaceutical device manufacturing, the stringent recordkeeping on the use and origin of component materials.

transpires: The process of a plant giving off water directly to the air (See page 13).

TS: Total Solids – The sum of total dissolved solids and total suspended solids (See page 18).

TSS: Total Suspended Solids – The residual matter which can be removed from a solution by filtration (See page 18).

turbidity: A suspension of fine particles in water that cause cloudiness and will not readily settle due to small particle size (See page 15).

turbidity units: Measurement of the relative ability of a solution to allow a light beam to pass through it.

two-bed: A pairing of cation and anion ion exchange tanks, typically operating in series. Best used for the deionization of relatively high volumes of water. Capable of product water resistivity of up to 4 megohm/cm (See page 46).

ultrafiltration (UF): Separation of one component of a solution from another component by means of pressure and flow exerted on a semipermeable membrane, with membrane pore sizes ranging from 10^Å to 0.2 micron. Typically rejects organics over 1000 MW while passing ions and small organics (See pages 27 and 57).

ultrapure water: Highly-treated water of high resistivity and no organics; usually used in the semiconductor and pharmaceutical industries (See page 28).

ultraviolet (UV): Radiation having a wave length shorter than visible light but no longer than X-rays. Ultraviolet light with a wave length of 254 nm is used to kill bacteria and destroy ozone (See page 63).

unloading: The release of contaminant that was originally captured by the filter medium.

USP: United States Pharmacopoeia which publishes standards for the pharmaceutical industry, including those for water quality. Was

established by the US Congress in 1884 to control drug makeup (See pages 22 and 78).

validation: In the pharmaceutical industry, the mandating of specific testing and recordkeeping procedures to ensure compliance not only with a specific quality but with a specific means to achieve that quality (See page 67).

vaporize: To convert a liquid into a vapor (See page 48).

velocity: Free air passing through a filter panel and measured in feet per minute (fpm). It is determined by the volume of air/min (ft^3/m) divided by the area of the panel (ft^2). It is expressed in this case as ft/min divided by feet per minute (fpm).

virus: Any of a large group of submicroscopic infective agents capable of growth and multiplication only in living cells of a host (See page 55).

viscosity: That property of fluids by which they offer resistance to flow. Measured in poise, kinematic viscosity, centistokes, saybolt universal seconds (SUS), seconds saybolt, degree Engler and degree Barbey, Gardner-Holt, etc.

VOC: Volatile organic compound – synthetic organic compounds which easily volatilize. Many are suspected carcinogens (See page 29).

voids: The openings or pores in a filter medium.

wash filter: A filter in which a larger unfiltered portion of the fluid flowing parallel to the filter element axis is utilized to continuously clean the influent surface which filters the lesser flow.

WFI: Water For Injection – high-purity water intended for use as a solvent for the preparation of parenteral (injectable) solutions. Must meet specifications as listed in the USP (See pages 22 and 78).

WHO: World Health Organization – part of the United Nations which has set the standards for potable water (See page 68).

NOTES:

NOTES:

Acknowledgement is made to the following for certain abstracted material:

- Industrial Filter / Pump Manufacturing Company
- Ontario Hydro
- Heating Piping & Air Conditioning Magazine
- Chapman & Hall

The following are trademarks of Osmonics:

AquaMatic Valves
ARIES Disposable Cartridges
CERATREX Controlled Porosity Ceramics
CLEARSHOT Filters
DESAL Membrane Elements
DURATHERM Membrane Elements
DURATREX Stainless Steel Elements
ECONOPURE RO Units
FASTEK Membrane
FLOTREX Pleated Cartridge Filters
FLOTRONICS Filters and Coalescing Devices
HYTREX Depth Cartridge Filters
LIQUI/JECTOR Liquid/Gas Coalescers
MACE Flow Control Components
Magnum Cv Valves
Membrana Element Housings
MEMTREX Pleated Cartridge Filters
MIST-TRACTOR Reverse-Flow Depth Coalescer
OREC Ozonation Systems
OSMO Reverse Osmosis Machines, Separators & Housings
OSMOSTILL Multiple & Single Effect Stills
Poretics Polycarbonate Membrane Filters
PORTAPURE II RO Units for Dialysis
PURTREX Depth Cartridge Filters
SELEX Depth Cartridge Filters
SEPA Membrane and Membrane Cells
SOLO RO Machines for Dialysis
SPIRALTEK Point-of-Use Ultrafiltration/Microfiltration Systems
STILOMATIC Industrial Stills and Tanks
THERMEVAP Steam Stills
TONKAFLO Multi-Stage Centrifugal Pumps
VAPE-SORBER Liquid/Gas Coalescers
VAPONICS Stills
VENTREX Pleated Cartridge Filters
VERATREX Filters

Use this form to order additional copies of the Pure Water Handbook

The PURE WATER HANDBOOK

Order this indispensable resource guide today!

Please rush me ____ copy(s) of OSMONICS Pure Water Handbook at \$9.95 each (US\$). I'd like to share this helpful information with co-workers and clients.



Name: _____

Title: _____

Organization: _____

Address: _____

Phone: _____

Fax: _____

Credit Card #: _____

Type: Visa MasterCard

Expiration Date: _____

Enclose check or money order, along with order form to:

Osmonics, Inc.
5951 Clearwater Drive
Minnetonka, MN 55343-8995 USA
Fax (612) 933-0141

(Please allow 4 weeks for delivery)

Order recap:

____ copy (s), at \$9.95 each (in US Dollars). TOTAL ENCLOSED = \$ _____

Please Complete and Return This Card

Please have a sales representative call: (_____) _____

Industry: _____

Also, send more information. My area of interest is:

- Clarification
- Condensate polishing
- Degasification
- Filtration
- Hazardous wastewater
- High purity/ultrapure water treatment
- Ion exchange
- Landfill leachate treatment & groundwater remediation
- Liquid storage tanks
- Membrane technologies (MF/UF/NF)
- Metals removal and recovery
- Oil/water separation
- Recovery technologies
- Resin sales & services
- Reverse osmosis
- Wastewater treatment industrial municipal
- University

My specific application is _____

If need is immediate, fax to (612) 933-0141

I plan to purchase: Within 6 months Within 1-2 years Over 2 years

Name _____

Title _____

Company _____

Address _____

City _____ State _____ Zip _____



OSMONICS

5951 Clearwater Drive, Minnetonka, MN 55343-8995, Phone (612) 933-2277, Fax (612) 933-0141
<http://www.osmonics.com>