

# MIND MACHINES

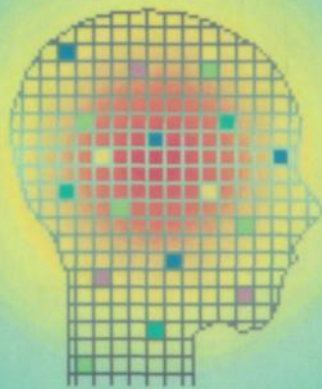

YOU CAN BUILD

G. Harry Stine

**MIND  
MACHINES  
YOU CAN BUILD**

by G. Harry Stine

*TOP OF THE MOUNTAIN PUBLISHING*  
Largo, Florida 34643-5117 U.S.A.

All rights reserved. No part of this book may be reproduced, utilized or transmitted in any form or by any means, electronic or mechanical— including photocopying, recording on any information storage and retrieval system—without written permission from the publisher, except for brief quotations or inclusion in a review.

Top Of The Mountain Publishing  
11701 South Belcher Road, Suite 123  
Largo, Florida 34643-5117 U.S.A.  
SAN 287-590X  
FAX (813) 536-3681  
PHONE (813) 530-0110

Copyright 1992 by G. Harry Stine

Library of Congress Cataloging in Publication Data  
Stine, G. Harry (George Harry). 1928-  
Mind Machines you can build/by G. Harry  
Stine.

p. cm.

Includes bibliographical references.

ISBN 1-56087-016-8: \$11.95

1. Machinery. I.Title.

TJ153.S774 1992

133.028-dc20

91-27801 CIP

Manufactured in the United States

## TABLE OF CONTENTS

INTRODUCTION	5
THE REALIST'S DILEMMA	9
DETECTOR RODS	21
PYRAMIDS	37
THE ENERGY WHEEL	61
PENDULUMS	83
THE HIERONYMOUS MACHINE	103
SYMBOLIC MACHINES	125
THE SYMBOLIC HIERONYMOUS MACHINE	143
THE WISHING MACHINE	165
POSTSCRIPT	181
BIBLIOGRAPHY	195

Devoted  
to  
Patsy and Clyde

## INTRODUCTION

The intent of this book by my friend and colleague Harry Stine is to challenge the technical community and amateurs to build these machines, then try to figure out why they work. All of them seem to violate the well-known laws of physics or mechanics. Thus, the challenge is to resolve the apparent contradiction.

In the history of science, the resolution of a discrepancy is one of the most fruitful ways to make progress. For example, it was Rutherford who saw an apparent contradiction in the course of his study of alpha particle emission by radioactive nuclei. He asked how it was possible for an alpha particle of measured range and energy to emerge from a nucleus without having the energy to penetrate the higher energy potential barrier around the nucleus - which could also be measured. Such penetration by an alpha particle was energetically

impossible. It was the challenge of this apparent discrepancy that led Gurney and Condon to the discovery and development of quantum mechanical tunneling which has been of major importance not only in physics but also to modern solid-state electronics.

In science, one progresses from an observation to a hypothesis about how or why the observed phenomenon works, then to an experiment in which one proves not only that the hypothesis is correct but that the hypothesis is indeed a theory. The theory must then predict other observable effects that can be tested and experimentally confirmed. The fact that a certain device in this book works does not mean that all our theories are wrong but only that our understanding of how these theories should be applied is faulty in this particular case. Essentially, we do not know everything. Indeed, what we do know may not be so, but may have some curious little twist that we have overlooked. Apparent violations of the laws of physics are usually an opportunity to make progress in our knowledge of the universe.

In science, we also seek to understand how nature works. And we often misunderstand or follow false leads. Actually, the "laws of nature" are generalizations from experience. For example, the violation of the law of gravity is punished not by a jail sentence but more fittingly by falling on one's face. Further, such generalizations are living concepts needing modification in details as we go along. Einstein did not prove Newton to be

wrong but rather provided the next approximation in our understanding of what actually happens when we make measurements at speeds approaching that of light. Mass, length, and time must be measured, taking the speed of light into account. A basic physics experiment is that of measurement, and it is important to carefully think through the details of the actor procedure in a step by step fashion.

Science is a living and growing discipline, and much remains to be done. This book will, one hopes, stimulate people to build and test these odd devices, to think about them, and perhaps to hit upon further approximations to our understanding of the universe. Good science is done not with apparatus but in people's heads **by thinking**.

- Prof. Serge A. Korff

*(Prof. Korff was professor emeritus, department of physics, New York University; Fellow, American Physical Society; past president and life member, New York Academy of Sciences; life member, American Society for the Advancement of Science; past president and director, the Explorers Club; and Chevalier of the Legion of Honor.)*



## Mind Machines You Can Build

## **CHAPTER ONE**

### **THE REALIST'S DILEMMA**

For more than thirty years, I've been working in high technology areas - rocketry, space flight, aviation, advanced industrial processes, electronic instruments, and space industrialization, among others. I've managed an industrial research laboratory, designed escape pods for pilots of supersonic aircraft, and been involved in high-technology marketing. None of these jobs existed in 1885. In fact, these scientific and technical areas would have been considered "magic" as recently as a hundred years ago, and I would have been tagged a wizard or, even worse, a witch.

## Mind Machines You Can Build

Many people still believe or would like to believe that much of the modern technology with which they must cope every day has indeed been created by wizards and witches.

We've all encountered machinery that seems to be magical or that doesn't or *shouldn't* work because our common sense or expertise tells us so. But in my career as an industrial research scientist and an engineer dealing with far-out areas of advanced high-tech, I've run onto a series of baffling, frustrating, and vexing machines and devices that *shouldn't work at all* according to what we presently know about the Universe.

But they do.

Sometimes they don't work for everyone. But they do work for some people.

The apparent fact that some things work for some people but not for others doesn't bother me. Although I enjoy good brass band music, I can't get a single musical note to come from a trumpet. Some people can, and some people can't. But playing the trumpet isn't a magical feat. It is mystical, however, as we'll see later. But people can teach other people how to do it. Perhaps I can't get music out of a trumpet because I've never been *trained* to play the trumpet. But I can't get music to come out of a trumpet *or* a violin.

I'm a "grubby-handed engineer." I can build things that work. I can usually discover why something doesn't work when it quits, and I can usually manage to fix it or

## The Realist's Dilemma

get it working well enough to get me to a place where a real expert can make it work properly again. I'm at home in a scientific meeting of the New York Academy of Sciences as well as at the controls of an airplane. I'm a pragmatic and skeptical person. I've run onto a lot of wild and wonderful devices that don't work as claimed. But if a gadget works, I'll use it.

So I'm not a mystic in the way I look at the world around me. Murphy's Law notwithstanding, I believe that if something works in a demonstrable and reasonably repeatable manner, there must be a reason why because the Universe isn't a place that behaves capriciously. Murphy's Law exists and the Universe only seems to be capricious occasionally because we still don't know everything there is to know about it. The nineteenth century philosophy of materialism says that we do indeed know everything there is to know about the Universe, but that belief seems to be incredibly presumptuous. As J.B.S. Haldane has observed, the Universe is not only stranger than we know, it's stranger than we can possibly imagine.

I've collected enough data and conducted enough experiments with these amazing gadgets now that it's time to put all the data together in a book so that other people with inquiring minds and an open outlook on the Universe can also try them for themselves.

## Mind Machines You Can Build

But I didn't write this for mystics or for those who dabble in the occult. This is a collection of how-to instructions for demonstrable gadgets that are somehow based upon technology we don't understand yet.

We don't know why or how some of these devices work, but apparently they work reliably for a large number of people. Scientists haven't explained them yet. But you don't have to accept the reality of these devices on blind faith. By following the directions given herein, you can build the strange device, test it, and determine for yourself whether or not it's a hoax.

Some of these machines may be precursors to the big scientific breakthroughs of the future. After all, the early parlor experiments with electricity and magnetism in the late eighteenth century are still used today in grade school and high school science classes to provide a background for understanding electronics, radio, television, and computers.

I can't tell you *what* particular scientific principles these devices demonstrate because I don't know what the *science* of the twenty-first century will be all about. I'm a futurist but not a prophet. My crystal ball is very cloudy indeed when I try to look beyond the year 2010.

But I *can* tell you something about the basic principles behind scientific methodology that will be as valid tomorrow as they are today:

## The Realist's Dilemma

The solid edifice called "Science" that looks so imposing and monolithic when viewed from a distance really isn't that way at all when you get close to it. As Dr. William O. Davis pointed out in 1962, "Science is a cracked and sagging edifice built upon the constantly shifting sands of theory." It's in the process of being continually built, re-built, modified, remodeled, and changed. Like New York City or the United States of America, it's never finished.

However, some scientists have tried to convince people this isn't so and that they alone know everything there is to know about the Universe. Therefore, these scientists occasionally need to be shaken out of their rut. Scientific and technical controversy must be generated from time to time to stir the pot and promote progress in human knowledge. As the famous aerospace scientist, Dr. Theodore von Karman, once observed, "How can we possibly make progress without controversy?"

My formal academic education is that of a physicist. After I'd graduated and obtained that important academic degree that amounts to a scientific union card, I was given my *real* education in the big outside world beyond the groves of academe. My work became more and more involved with applying scientific principles in order to solve technical problems. Thus I was converted from a scientist into an engineer who had to deal with things as they are, not with the reasons *why* the Universe worked in that particular manner. ("Never mind theoriz-

## Mind Machines You Can Build

ing why; just get it built or working and in saleable condition by next Wednesday!") By and large, however, the principles of physics and other sciences that I'd learned in college comfortably supported my engineering work.

But an unquestioning faith in what they'd told me was true during my formal academic education and even some of the pragmatic principles I'd learned afterwards was shattered by my first encounter with an inexplicable machine in 1956.

John W. Campbell, Jr., the late editor of *ANALOG magazine*, published a science-fact article describing a strange device known as a "Hieronymous machine" for which a U.S. patent existed. He gave explicit instructions on how to build one and invited the readers of the magazine to try it for themselves before they labelled it an impossible fraud.

The device - which is described in this book is an electronic instrument whose purpose is to determine the qualitative constituents of a metallic alloy. It uses a "tactile" detector that is stroked and that "feels different" when the device detects a given metallic component in an alloy.

However, Campbell reported that the Hieronymous machine worked whether or not it was plugged into a wall socket. He also claimed that it would work if you made one simply using the *diagram* of the electronic circuit and substituted thread for wire.

## The Realist's Dilemma

This open invitation to blow away an obvious sham, fraud, and hoax was too much for me. I built one of the "symbolic" Hieronymous machines to prove to the world once and for all that it was a total impossibility.

It worked.

I still have it, and it still works.

But it works for some people and not for others.

I don't know *why* it works or *how* it works, but it does. I don't know how to begin conducting truly scientific research to answer these questions because I don't know what questions to ask or even what measurements to make. It's just not possible with the current state of the art in science and technology to be Kelvinian about it, and I am a firm believer in the advice given by Lord Kelvin (William Thompson) in 1886:

*"I often say that when you can measure something and express it in numbers, you know something about it. But when you cannot measure it, when you cannot express it in numbers, your knowledge is of a meager and unsatisfactory kind; it may be the beginning of knowledge, but you have scarcely, in your thoughts, progressed to the level of science, regardless of what the matter may be."*

Obviously, therefore, the Hieronymous machine and other amazing mind devices that shouldn't work but do are not scientific and are not yet amenable to scientific analysis. Various hypotheses concerning how they might



## Mind Machines You Can Build

work have been put forth, but these hypotheses have yet to be rigorously tested and thereby transformed into theories.

In the meantime, the machines are fascinating. Most of them are simple to build. Most of them will work for most people. Once a group of "garage gadgeteers," the sort who have created the basic foundations for most modern science, begin playing around with them, someone stands a good chance of eventually coming up with a testable hypothesis that will at last provide a basis for the establishment of the scientific field which embraces these machines.

Or perhaps not. The history of science and technology is not only rife with serendipitous discoveries that changed the world but also ideas, concepts, and gadgets that didn't work out right in spite of everything. Be aware that there are more failures than successes, more frauds and hoaxes than straight arrows.

In any event, here are some impossible machines that work for some people, that anyone with some manual dexterity can build in a home workshop, that anyone can build and test for himself.

I repeat: This is not an occult book. It's a book of experiments with weird machines. I haven't included any machine or device that I haven't built, worked, or tested myself. I don't ask the reader to believe that these machines work. I merely present a description of each machine, what it's purported to do, how it worked for

## The Realist's Dilemma

me, exactly how to build it, and precisely how to operate it. The remainder of the exercise is left up to the reader who's free to experiment or to snort "Impossible!"

But be careful before you snort, "Impossible!"

We often have the tendency to snort, "Impossible!" when confronted with a radically new idea, concept, or device. But these machines are different. They can be built. They can be tested. They are tweekers of the curiosity. They shouldn't work, but often they do.

And if you don't believe this, why don't you see for yourself?

The basis of scientific endeavor is the reproducible experiment. And the concept of reproducibility also includes the possibility that the experiment will fail the same way every time.

Right down at the basic level, this is a book about magic, after all. But it's "magic" as defined by Robert A. Heinlein: "One man's magic is another man's technology-

And Arthur C. Clarke advises, "Any sufficiently advanced technology will be indistinguishable from magic."

The book is a "how-to" instruction manual. Its individual chapters are each devoted to a single strange machine. Each chapter starts out with a brief description of the device followed by a brief history, and step-by-step instructions for building it. A set of instructions for using the device is provided along with a suggested program of

## Mind Machines You Can Build

experiments that can be conducted. The only thing I'm telling you is: Here it is; build it and try it for yourself, because it appears to work for some people, it can be built, and the author has either tried it and can work it, or tried it and can't work it. (I'm pretty good with most of the gadgets.)

I have gone out on a limb (as if some of my colleagues won't believe that I've already done so) by daring to suggest one or more hypotheses concerning why the machine is doing what it's doing. But in many cases, there is no tenable hypothesis, and I'm forced to simply say, "I haven't the foggiest notion why it works."

I don't believe any of the gadgets are dangerous. No reports have been received that any of them or the use of any of them has caused physical or mental injury to anyone. However, I must state the following caveat which the reader must keep firmly in mind at all times: It's possible to be hurt by *anything* and it's possible to misuse *any* device made with any level of technology. People continue to be burned by campfires, and the technology of fire is millennia old. However, there have been no reported problems with anything herein. Most of us have internal "programming" that trips our internal "circuit breakers" to keep us from going over the edge.

Don't dismiss any of the devices as an impossible hoax just because it *sounds* impossible to you or because you think it's fraudulent and can't work. Or because somebody told you it was one or more of these. Here's

## The Realist's Dilemma

your chance to find out for yourself. You'll then be able to say that the gadget works or doesn't work because *you* tried it yourself. You didn't take someone else's word for it.

These gadgets may indeed work because of magic (a technology we don't yet understand) but they aren't mystical because I can tell you how to build one and how to operate it without subjecting yourself to ten years' of guru training, fasting, and all the rest of the curriculum of oriental mysticism.

Some people won't be able to make some of these devices work. Others may be able to make only a few of them work. Some will be able to work all of them. This will create *enormous* controversy.

(If you don't pucker your lips just right and blow with just the right force into the mouthpiece, you'll never get a single musical note to come out of that trumpet. But the trumpet is there, and other people can make great music come out of it. Are trumpeters magicians?)

I've been forced to draw the conclusion that these mind machines are examples of future science. They're in the same situation today that electricity and thermodynamics were in the early part of the nineteenth century and as some folk medicine was at the beginning of this century. The mere fact that these devices exist and work for some people means there must be some sort of scientific basis for them. Therefore, we will be able to un-

## Mind Machines You Can Build

derstand and explain them some day. They can't and shouldn't be ignored. They're going to provide the foundations for the science of the next century.

Besides, it's exciting, fascinating, frustrating, and perplexing to build and work with them, if you can.

But don't be upset if one doesn't work; try it on someone else. And if the other person can make it work and you can't, why? What's really going on here?

The scientists of the twenty-first century may know, and they may have found out from some flash of insight that came as a result of someone experimenting with these mind machines and others.

You may be the founder of a whole new field of scientific investigation and technological endeavor!

Have fun.

## **CHAPTER TWO**

### **DETECTOR RODS**

#### **Basic Description:**

This device consists of either a single stick, rod with a forked end that allows it to be held in both hands or two separate sticks or rods, one of which is held in each hand.

## Mind Machines You Can Build

The device had been primarily used for locating hidden underground objects or materials such as pipes, tunnels, and water. However, some experiments by the author indicate that the device can be used to determine the location of any object the user desires.

The device is grasped in both hands and held in front of the operator. When the device passes over the underground object being searched for, or when the operator faces in the direction of the object being searched for, the device appears to operate with no observable action on the part of the operator. If it is a single, bifurcated or forked rod, the single end not in the hands of the operator will abruptly swing downwards. If dual rods are being used, the rods will either swing apart if the operator is holding them together or, if they are being held so that they point away from one another, they will swing toward each other. The action is quite strong, and many operators claim that they cannot stop the rods once the swing has started.

### Historical Background:

Many readers will immediately recognize this device as the legendary "dowsing rod." Other names include "water rods" or "witching rods." In the form of a branched or forked stick or twig- some operators claim that only a live forked willow branch recently cut will

## Detector Rods

work properly - the device has been used in Europe and America for unknown centuries. Its actual source is shrouded in folklore, much of which is considered to be evil or the "work of the devil" because of the inexplicable operation of the device. In recent times, dowsing rods were used by United States Marine Corps soldiers in South Viet Nam for the purpose of locating underground Viet Cong tunnels. However, no official reports of this exist and, as might be expected, no official confirmation of this use has ever been made.

Readers wishing to obtain more information should contact the American Society of Dowsers, P.O. Box 24, Danville, VT 05828.

### Author's Experience:

The author built and experimented with his first pair of dowsing rods in 1955 at the rocket research center at White Sands Proving Ground and around his home in Las Cruces, New Mexico. The basic metal dowsing rods described later in this chapter were used. The author was successful in locating the underground water and sewer pipes leading into his home. At a later time, he found the rods useful in locating misplaced objects, especially books.



## Mind Machines You Can Build

In 1961 and 1962, he witnessed the use of dowsing rods by the Water Department of the Town of Milford, Connecticut for the precise location of underground water and sewer lines prior to excavation.

On February 2, 1966, the footvalve of the ejector pump failed at the bottom of the 150-foot-deep water well in the back yard of the author's home at 127 Bickford Lane, New Canaan, Connecticut. This required that the well be uncovered and the piping pulled to replace the faulty foot valve. The author had a plat drawing which indicated the location of the well head. But initial excavation by well company employees failed to uncover the well head at the indicated location. The foreman took a pair of metal dowsing rods from his truck and proceeded to locate the well head within a few minutes.

In the upper valley of the Arkansas River between Pueblo and Canon City, Colorado, dowsing rods and "water witches" are extensively used for the purpose of locating the proper sites for drilling wells that will produce *good* water at depths considerably less than would otherwise be required on the basis of the study of geological structures.

## Detector Rods



*Figure 2-1:* Employee of the Milford, Connecticut, water company using detector rods to locate city's water mains. Employee did not wish to be identified nor would he permit a second photo session.

## Mind Machines You Can Build

### Instructions for Fabrication, Economy Model:

This model is an expensive one that may be quickly fabricated as follows:

1. Obtain two (2) coat hangers or clothes hangers made totally from wire. The size of the wire and the type of wire are not critical. However, the wire should be stiff enough so that it doesn't bend when held horizontally by one end with the other end free.

2. Straighten each coat hanger wire.

3. Six (6) inches (15 centimeters) from one end, make a right angled bend in each wire.

4. For safety's sake, make another right angle bend in the other end of each wire approximately one (1) inch (2.5 centimeters) from the end; this will prevent the free end of each rod from sticking into something... such as another person's eye!

Operate the Economy Model as described in the Operating Instructions below.

### Instructions for Fabrication, Deluxe Model:

This model is intended for long life, high reliability, and good sensitivity, features that are useful when the device is used in the field or when experiments are being conducted with many users. The cost is less than \$5.00.

## Detector Rods

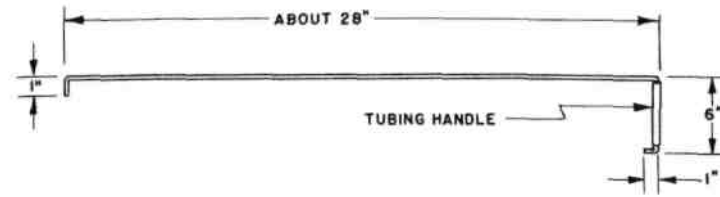

*Figure 2-2: Drawing of dowsing (detector) rod.*

The Deluxe Model can be fabricated by anyone using simple tools. The materials may be found in any hobby store or welding supply store.

### *Bill of Materials:*

A. 2 each hard steel wire ("music wire") 1/8" diameter x 36" long.

B. 1 each seamless thin-wall tubing, aluminum or copper (material not critical), 3/16" diameter x 12" long.

### *Tools Required:*

- A. Hack Saw.
- B. Slip-joint pliers or "Vise-Grips."
- C. Bench vise (optional).
- D. Small rat-tail file.

### *Fabrication:*

1. With the hack saw, cut the 12-inch length of tubing into roughly two equal 6-inch lengths.

## Mind Machines You Can Build

2. Remove the burrs on the cut ends of the tubing using the rat-tail file.

3. Using the slip-joint pliers, Vise-Grips, or bench vise, make a right-angle bend in one end of each rod approximately 7 inches from the end.

4. Slip a 6-inch length of tubing over the 7-inch bent section of each rod.

5. Using the pliers or bench vise, make a short bend in the free end of the rod sticking out of the piece of tubing. When completed, the rod should rotate freely inside the tubing.

6. Using the pliers or bench vise, make a right angle bend 1 inch from the other end of each rod.

When finished, you will have two nearly identical metal rods bent as shown in Figure 1. The tubing forms a low-friction rotating handle on one end of each rod, permitting the rod to rotate with ease inside the tubing.

The Deluxe Model will last for years if properly cared for and the low-friction handles kept free to rotate. The author's Deluxe Model was built in 1955 and is still in use.

## Detector Rods

### Operating Instructions:

Both the Economy Model and the Deluxe Model operate in the same manner.

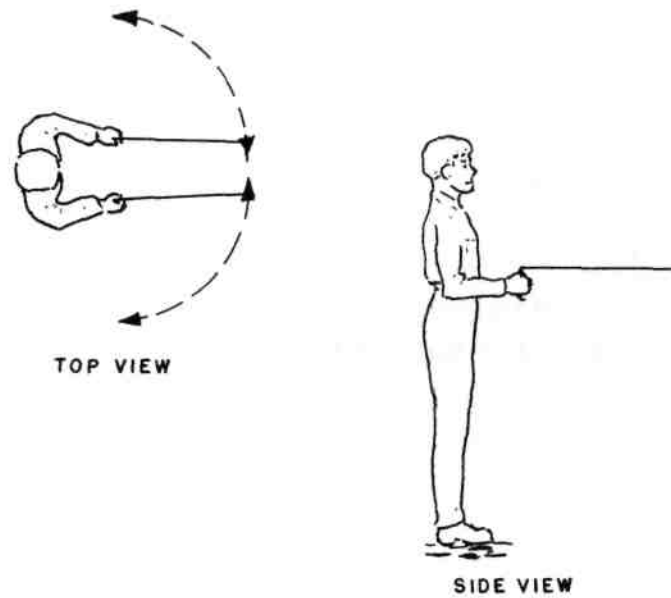

*Figure 2-3: Holding and using detector rods. To*

#### *Operate:*

Step 1: Decide what you wish to locate. Beginners usually choose some easy underground object such as the water or sewer pipe leading to their house. In most cases, the place where the water line enters the house is known, but the location of the sewer line isn't. And, in

## Mind Machines You Can Build

most cases, the general alignment of either underground pipe isn't known. For other suggested items to locate, see the "Experiments" section below.

Step 2: Grasp the low-friction tubing of each rod in each hand.

Step 3: Hold the pivot axis of each rod vertical so that each rod is in a general horizontal position (see photo).

Step 4: Place both of your hands in front of you, holding the rods horizontally before you (see photo). Some people find that their wrists must be touching. Others find that there is no specific way in which they must hold the rods.

Step 5: By tilting your hands, arrange the rods so that they are (a) parallel to one another and pointing ahead of you, or (b) at 180-degrees to one another (pointing away from one another) to both sides of you (see photo).

Step 6: Begin searching for the object you wish to locate by either turning or by walking slowly.

Step 7: When you pass over the object you're searching for, or when you're pointed toward it, the rods will swing, indicating that you have located the object.

## Detector Rods

### Operating Hints:

It doesn't make any difference whether the rods are together in front of you or pointing directly away from one another; when they swing, they swing. When you've located what you're looking for, the action of the rods is unmistakable; when they swing, they swing. Operators continually report (and it's confirmed by the author) that there seems to be some sort of definite, positive physical force that makes the rods move. Furthermore, they seem to move in unison.

### Experiments:

If you misplace something, try using the rods to help you locate it. Put the rods in hand and simply begin to turn around; when you're pointed in the direction you should go to move toward the object, the rods will swing. You should be able to pin-point its location using the principles of triangulation by taking "sightings" from different locations; where the lines of position cross is where you're most likely to find what you're looking for.

Do not be disturbed if you happen to obtain erratic data from such location experiments. They may only mean that the object is irretrievably lost in such a manner that you have no possibility of recovering it. The author discovered this phenomenon when searching for a misplaced book; the meaningless results finally re-



## Mind Machines You Can Build

minded him that he'd lent the book to a friend while living in Denver and he was at the time living in Connecticut.

Modern instrumentation should be able to measure the actual torque on each rod as it swings. To the best of the author's knowledge, no such measurements have yet been made.

Modern instrumentation should also be able to detect any tilting of the operator's wrists or other movements that may produce rotation of the rods. To the best of the author's knowledge, no such measurements have been made. However, data from such experimental measurements still may not answer the basic question, "How does the operator know when to tilt his wrists to accomplish this?"

Some investigators will want to design experiments that will offer incontrovertible proof that this device actually works. Data from such "wild" sources as users or historical data on water witches and dowzers would not normally be acceptable in such controversial and apparently unscientific (scientifically inexplicable) situations such as this.

The biggest problem faced by any investigator when designing experiments in an unknown area such as this is: What should be measured? What measurements will be meaningful? And, basically, what is the nature and level of importance of significant data? What *is* significant data?

## Detector Rods

Experiments need to be conducted with a large experimental universe of operators, the larger the better, to determine the percentage of the population capable of working the rods. Double-blind techniques should be used to validate the data. Some experiments, however, will serve only to provide statistical data on the percentage of the population capable of successfully using the rods. They won't determine why the rods work or what sort of person can make them work unless the experiment is structured to determine the specific personality traits of the user.

Other experiments need to be conducted to verify whether or not the rods can be used to actually find an object whose location is truly unknown to the operator, or whether the operation of the rods depends upon some manner of subliminal recall on the operator's part, the rods acting merely as a symbolic crutch.

The influence of mood-altering substances (such as alcohol, nicotine, and caffeine) on an operator's ability may well uncover some interesting new data. However, experiments with other mood-altering drugs such as meprobamate should be conducted only by qualified, licensed medical practitioners or under their direct supervision.

No experiment yet designed offers any hope of determining the actual operational cause behind the apparently successful use of dowsing rods. At best, most experiments will lead only to experimental confirmation

## Mind Machines You Can Build

of the phenomenon or to statistical data concerning the talented population. However, to the best of the author's knowledge, none of these basic experiments have been done and reported in the open literature. Perhaps once this has taken place, interested parties may be able to proceed further in the design of experiments to determine operational causes.

### What If It Doesn't Work?

If you cannot get the rods to work for you, you are most probably one of those people who do not have the unidentified "talent" for them. Not everyone can play the violin. Data to date indicates that whether or not you believe the rods will work has little or nothing to do with your ability to make them work. The author was a confirmed disbeliever when he first tried using the rods. However, if you can't make them work, don't throw them away. Try the rods on your friends, and you might be surprised at who can operate them and who can't. At this time, the ability or inability to operate dowsing rods does not appear to correlate with any known personality trait, religious belief, level of education, or ethnic background.

## Detector Rods

### Hypotheses:

The existence of the dowsing rod phenomenon has naturally led people to formulate a number of hypotheses concerning how the rods work. Among the most interesting and the most acceptable of these hypotheses (another word for unconfirmed, unsubstantiated, wild guesses) are:

The operators may somehow know, perhaps on a subconscious level, the location of the object they're searching for.

The rods might serve only as a "crutch" to stimulate the recall of memories concerning the location of the object.

The operators may actually sense the presence of what they're looking for and use the rods only as an "amplifier" or a physical "detector" of the presence of the object, the rods actually being swung by subconscious movements of the operator's wrists.

There are other less-tenable hypotheses involving "psychic forces" or extrasensory perception. At this time, it's impossible to confirm such hypotheses to the level of credibility demanded by scientific peer groups. Such hypotheses must be viewed as "beliefs" or the results of wishful thinking rather than the products of data from carefully-conducted experiments. Perhaps some reader may be able to design, carry out, and validate a repeatable experiment that will lead toward the develop-

## Mind Machines You Can Build

merit of a valid hypothesis. Although the human mind is an incredible device itself, and although we are learning more and more about it every day, the actual existence of "psychic fields" or "mental forces" isn't confirmed. But, in analogy, the nature of the electromagnetic field wasn't known, much less suspected, by the early scientists of 1800, either.

### Conclusions:

The author has seen dowsing rods used successfully on many occasions. The use of dowsing rods seems to be a repeatable phenomenon. The author also happens to be one of those who can make them work for him, whereas his wife cannot. Reported observations of the phenomenon from reliable observers abound. The device is simple, inexpensive, can be readily made by most people, and can be used to conduct numerous experiments, most of which haven't been done yet, to investigate the reasons for its operation. The nature of these experiments is such that the basic ones can be carried out by nearly anyone willing to follow the basic guidelines for the design and conduct of scientific experiments.

## CHAPTER THREE

### PYRAMIDS

#### Basic Description:

Tetrahedral pyramids made from electrically non-conducting materials have been used to maintain sharp cutting edges on steel instalments, dehydrate or mummify organic materials, and improve the growth rates of plants. The precise mechanism(s) by which a hollow pyramidal shape accomplishes these things is unknown.

## Mind Machines You Can Build

It appears to be a passive concentrator of energy, but the mechanism and type of energy has not yet been thoroughly defined. However, a large number of confirming experiments have been carried out to verify the performance claims of investigators, advocates, and individuals applying for domestic and foreign patents. These experiments tend to confirm the existence of some manner of energy concentration and the reality of the claims.

### Historical Background:

Many advocates and proponents of "pyramid power" tend to base their hypotheses on elements from Egyptian history and mythology. Some of these people believe that the ancient Egyptians possessed arcane knowledge that led this early riverine culture to build the fabled pyramids of Giza on the basis of either scientific principles unknown to us today or empirical data acquired by means often classified as "bizarre" by the detractors of the Egyptian hypotheses.

Regardless of whether or not any of the hypotheses derived from ancient Egyptian history may be true, the demonstrable fact remains that tetrahedral pyramid shapes appear to do *something* to objects placed inside them and offer a subject amenable to experimentation by modern techniques carried out by both professional and amateur scientists.

## Pyramids

The modern historical background of pyramid research began in the 1930s. Antoine Bovis, the owner of a hardware store ("Quincaillerie Bovis et Passeron") in Nice, France, took a trip to Egypt in the 1930s and visited the "great pyramid" of Cheops at Giza. While inside the King's Chamber of the great pyramid, Bovis noticed a garbage can filled to the top with dead small animals which the guide told him wander in the structure from time to time, become lost, and die. It seemed unusual to Bovis that these dead animals appeared to be completely desiccated (mummified) with no trace of decay or putrefaction. Upon his return to Nice, he built a plywood pyramid in which he placed a dead cat. The carcass of the cat did not decay but became desiccated. Unfortunately, Bovis did not believe in the scientific method nor in conducting proper scientific experiments with full documentation. He made no attempt to present papers before scientific societies where his work would have been subjected to peer review, comment, and criticism and so others could duplicate the experiments for verification of results. Bovis preferred to believe in intuition and faith. Although the synthesis of seemingly unrelated data by intuition is the basis for all great advances in science, pioneers such as Albert Einstein, Max Planck, Charles Darwin, Edwin Hubble, Marie Curie, and Sir Alexander Fleming followed their intuitive discoveries by publication, permitting and encouraging others to verify and expand their results and hypoth-



## Mind Machines You Can Build

eses, while at the same time opening their work to comment and criticism. The failure or refusal of Bovis to do this probably resulted in a fifty-year set-back to the serious scientific examination of his data.

Following World War II, a Czechoslovak radio engineer, Karel Drbal, read some of Bovis' material. Drbal worked in the Radio Institute of Research in Prague. Radar and microwaves were part of the technology that had mushroomed during the war. Many microwave antennas and other devices are horn-shaped or pyramidal in nature. Drbal began to experiment with small pyramid models for desiccation and dehydration because he either suspected some phenomenon connected with microwaves or wanted to prove Bovis wrong ~ we 11 never really know for certain.

As has happened, to so many others who have researched the pyramid phenomenon with the goal of proving that it was a hoax, Drbal discovered that tetrahedral pyramid shapes *did* desiccate both organic material and fine crystalline structures. Metals and metallic alloys are basically crystalline in nature and structure. The steel alloys used in fine cutting tools are composed of very small crystalline structures throughout. Drbal discovered that he could shave with the same razor blade 100 to 200 times if he placed it inside a cardboard pyramid each day after use. More as a joke than anything else, Drbal applied for a Czech patent on a "Pharaoh's Shaving Device" on November 4, 1949. Normally, Czech

## Pyramids

patents are granted after an examination period of two to three years, but it took Drbal ten years to get his patent. It was granted on August 15, 1959 only after he'd proved to the Chief Examiner, Engineer Vrecion, that a pyramid did indeed maintain the edge on a razor blade. In the course of this decade-long examination period, Drbal performed some experiments and made some measurements that will be discussed later.

Cardboard pyramids came into use in the Czech army as a way for soldiers to keep their razors sharp. Soldiers in the Soviet army picked up this concept in later years. The Soviet soldiers would get only one razor blade per month, so it's important to them to keep their razors sharp. However, no company has placed pyramids on the market anywhere, including eastern Europe. Drbal believes his invention has been suppressed by razor blade manufacturers who do not want to see their products used ten times as long. This reaction, however, is typical of some inventors of strange machines who often believe there are paranoid plots to keep their inventions secret. The lack of pyramid products more likely arises from the fact that they are so easy and simple to quickly build using available materials.

A number of European researchers began to experiment with Drbal's pyramids. Drbal came into correspondence with pyramid researchers in Sweden, West Germany, France, Great Britain, and the Soviet Union. In the United States, little was known of the

## Mind Machines You Can Build

pyramid phenomenon even though Nobel laureate (physics, 1968) Dr. Luis W. Alvarez attempted to locate hidden chambers inside the Chefren's Pyramid (near the Cheops' Pyramid), using cosmic ray absorption measurements, was unable to correlate his data, and stated that "something outside of known science is happen-ing.

In the United States, pyramid research was taken up by Dr. G. Patrick Flanagan who had been interested in electromagnetic energy fields connected with living organisms. When he was fourteen years old, Flanagan began experimenting with a phenomenon discovered and reported by Count Alessandro Volta (1745-1827) in 1800 and tagged "electrophonic hearing." By 1962, Flanagan had perfected his "neurophone," a device which electronically stimulates the skin to produce hearing. Dr. Flanagan is a very private individual not totally unlike many inventors. The author has known him personally since 1962. Flanagan prefers to carry out research on his own, seeking knowledge for the sake of knowledge with second priority being given to reporting his results in scientific journals.

In 1980, Flanagan presented his results in a book, *Pyramid Power*, which he published himself. His second book, *Pyramid Power II*, was published in 1981 and reports on pyramid experiments performed by eight qualified and respected scientists who were funded by grants from the Mankind Research Foundation, 1110

## Pyramids

Fidler Lane, Suite 1215, Silver Spring, MD 20910, from February to April 1975. These tests were properly designed and conducted according to the strictest scientific and statistical protocols. They revealed increased growth rates of pea and bean plants, improved preservation of raw hamburger meat, and decreased growth rates of throat and yeast bacteria placed inside a structure shaped as a tetrahedral pyramid. Less definitive results with a lower level of confidence indicated that the weight of crystals formed from the cooling of supersaturated solutions might have been increased, that dead organic materials might have been preserved longer, and that the death or decay rates of live plants might have been decreased. Tests on human volunteers who slept for several nights inside pyramidal tents provided a subjective consensus that there had been a change in the quality of sleep, vividness of dream recall, overall emotional state, and openness to new experiences. However, the changes were not in the same direction for all group members.

### Author's Experience:

The author has built miniature pyramids with 6-inch and 12-inch bases as described below, fabricating them from both shirt cardboard and Crescent No. 201 hot press medium weight illustration board. Each had access holes with a diameter of 2 inches and 4 inches respectively on all four surfaces. The author determined

## Mind Machines You Can Build

to repeat the Drbal experiment with razor blades since this test is easily conducted and the results unambiguous to anyone who has ever shaved with a dull razor. When a razor's edge is dull, there is no doubt whatsoever of this because of the extreme discomfort associated with shaving one's whiskers with a dull razor blade.

Six Gillette one-shot razors were selected at random from the display at a convenience store. One of these was selected at random and visually tagged to identify it. Each morning, the author shaved with the two razors using Gillette "Foamy" shaving cream. One razor was used to shave the left side of the face, and the other was used to shave the right. On a day-to-day basis, razors were used to shave alternate sides of the author's face. At the end of each shaving session, both razors were simultaneously cleaned in hot, running water. The tagged razor was placed inside a 6-inch cardboard pyramid as instructed by Drbal - i.e., with the pyramid aligned to magnetic north and the razor placed in the center of the base of the pyramid with the edge of the blade aligned to magnetic north. The untagged razor was placed in a drawer of the bathroom washstand.

The author shaved twenty-four times with the razor kept inside the pyramid. It was impossible to shave with a control razor more than three times. Four control razors were used up while the experimental razor inside the pyramid was in daily use.

## Pyramids

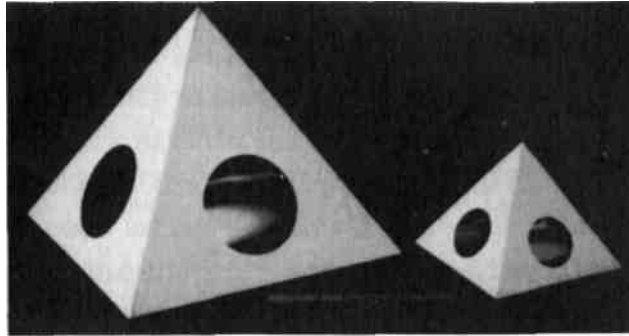

Figure 3-1: Experimental cardboard pyramids used in the author's re-run of the Drbal razor blade test.

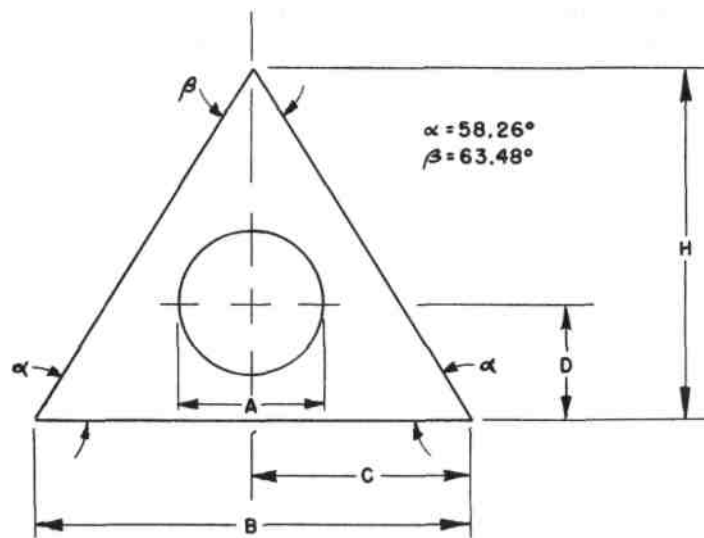

Figure 3-2: Template for constructing pyramid sides. See Table 3-1 for dimensions.

## Mind Machines You Can Build

A repeat experiment was conducted with six more disposable razors but with the base of the pyramid not aligned with magnetic north. The same number of shaves (twenty-four) were possible with the experimental razor kept inside the pyramid, while the control razors could be used only three times before becoming painfully dull.

The gross results from these simple experiments caused the author to conclude that "pyramid power" was not a hoax.

Further tests were conducted by the author and by other individuals using the pyramid matrix made by Flanagan and shown in the accompanying photograph. The basic fact that a pyramid shape does indeed maintain the edge on a razor was confirmed.

### Instructions for Fabrication:

The fabrication of a miniature model of the Cheops' pyramid is not difficult.

TABLE 3-1: DIMENSIONS OF EXPERIMENTAL PYRAMIDS					
NOTE: Refer to Figure 3-2 for dimensional symbol references, All dimensions in inches.					
Base	Height	Side	Hole Dia	Center	of Hole
X&B	Y	H	A	D	C
6	3.82	5.71	2.00	1.60	3.00
12	7.64	11.41	4.00	3.20	6.00
18	11.46	17.12	6.00	4.80	9.00
24	15.28	22.82	8.00	6.40	12.00

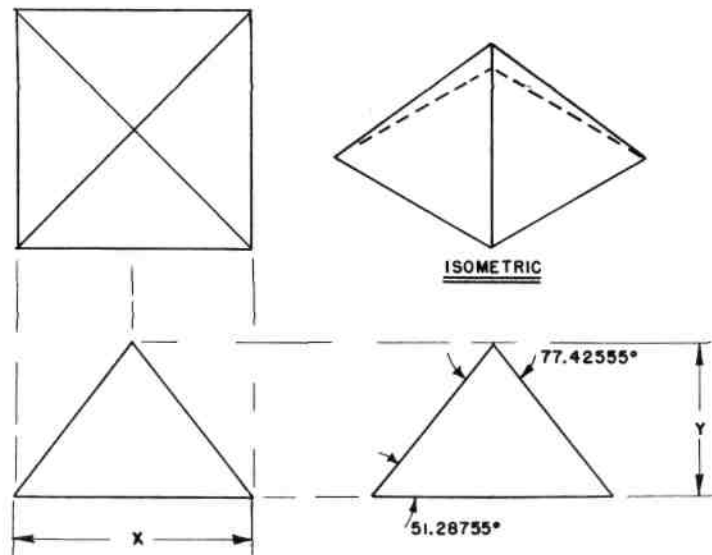

Figure 3-3: Basic three-view and isometric drawing of the experimental pyramid shape.



## Mind Machines You Can Build

To make it easier to gain access to the interior of the pyramid, cut circular holes in all triangular faces. The diameter of the access holes can be as much as one-third the base dimension of the pyramid - i.e., two inches diameter for a six-inch pyramid, four inches diameter for a twelve-inch pyramid.

There is nothing critical concerning the material used to fabricate a pyramid. However, for test purposes, they can be easily made from shirt cardboard, corrugated cardboard, or stiff manila. The only requirement is that the complete pyramid be sturdy enough to be picked up, moved, and otherwise handled. For advanced experimental purposes, pyramids can be made from sheet plastic (plexiglass, fiberglass, sheet styrene, etc.). Readers may wish to experiment with pyramids made from sheet metal and welded or soldered together along the edges.

Using a rule and a pencil, lay out the dimensions of the pyramid on the material and then cut the square base and four triangular sides from the material. Accuracy of dimensions and straightness of cuts are not critical, but try to measure and cut accurately in order to make parts fit better parts fit better and assembly easier .

Cardboard and paper pyramids of sizes up to twenty-four inches can be assembled using cellophane tape to hold the parts together at their edges.

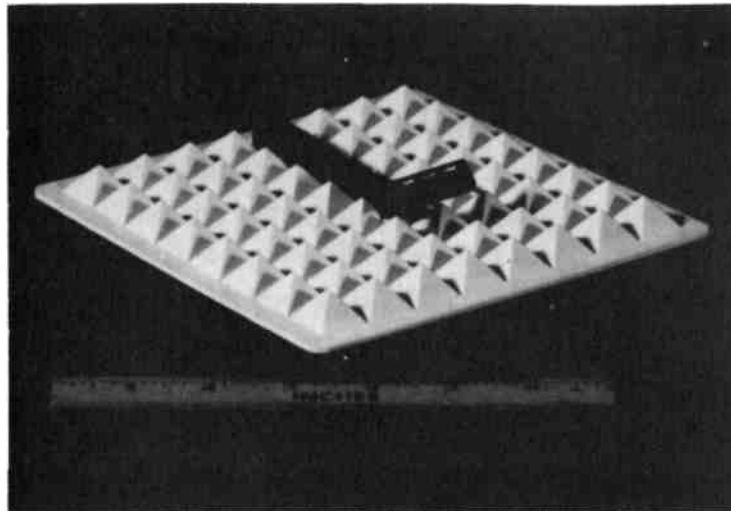

*Figure 3-4:* This plastic pyramid matrix produced by Flanagan was also used to conduct the Drbal razor blade tests with the razor placed as shown.

Lay the square base on the table and place the triangular sides flat on the table with each of their bases flush with the sides of the square base piece. Fasten each triangular side to one edge of the base piece using cellophane tape.

Fold each of the triangular side pieces upward so they meet at the apex of the pyramid. It may be easier to do this starting with two adjacent sides, then bringing each of the two other sides up one at a time.

Fasten the edges of the triangular side pieces together using strips of cellophane tape.

## Mind Machines You Can Build

If you have been careful while measuring and cutting, the pyramid should be neatly even and come to a uniform apex.

The test pyramid is now completed.

### Operating Instructions:

Early experimenters such as Drbal maintained that a pyramid had to be aligned with the local magnetic north. Flanagan discovered that this orientation was not necessary. Other researchers believed that the object to be processed should be placed at the scale location of the King's Chamber of the Cheops' pyramid - i.e., about one-third the height of the pyramid up from the base directly beneath the apex. However, Flanagan again showed that an object could be located anywhere within the pyramid and be subjected to the same unknown energies.

The easiest and most dramatic experiment that can be conducted with a pyramidal shape is the classic razor blade experiment. This requires a 12-inch or an 18-inch pyramid.

Obtain at least six good quality razor blades or disposable razors.

Select one at random and mark it for identification.

## Pyramids

The experiment may be conducted by either men or women. Men will want to shave their faces. Women can conduct the experiment by shaving their legs. For the sake of clarity and brevity herein, the experiment will be described as it is conducted by shaving the face; the same procedure can be used to shave legs.

Each morning, shave one side of the face with the razor kept inside the pyramid. Shave the other side of the face with one of the "control" razors.

Alternate the side of the face shaved each day with each razor.

Use a good quality shaving cream, and use the same shaving cream product each day. Don't shift from product to product during the test.

After shaving each day, wash out both razors with hot running water.

Place the marked razor inside the pyramid. Place the unmarked control razor in the normal place you would store a razor.

Keep a written record of your shaves and of your subjective reactions to the sharpness of each blade.

If the control razor becomes dull and therefore painful to use for shaving, substitute a fresh new control razor. Be sure to note this in your record.

## Mind Machines You Can Build

### Experiments:

The razor blade experiment is perhaps the classic one. But there are several others that can be conducted to verify the results of the tests conducted by the eight scientific researchers for the Mankind Research Foundation.

#### *1. Growth of bean sprouts:*

Obtain a package of bean seeds. Place the seeds on a wet sponge and permit them to germinate. Once they have developed their rudimentary roots and stems, divide the group randomly in half. Place each experimental group on its own sponge soaked in 50 milliliters (about 2 liquid ounces) of water. Cover both groups with a wet paper towel. Place one group inside a pyramid and the other in another location in the same room. After five days, measure the length of the bean sprout roots. Reference points for measurement are defined as the distance from the point where the root leaves the bean to the tip of the root.

#### *2. Decay of hamburger meat:*

Obtain a quarter-pound of hamburger meat. Divide the sample into two equal portions of about an eighth of a pound (100 grams) each. Place both samples in shallow

## Pyramids

saucers. Place one sample inside a pyramid shape. Place the other in another location in the same room. After five days, compare the appearance and odor of the samples.

### **3. *Yeast bacteria:***

Mix approximately 1/4-ounce of Brewer's Yeast with one-half cup of water heated to a temperature of 100 degrees Fahrenheit. Allow the culture to grow for six hours. Divide the culture into two equally-sized portions and place each in a clean saucer. Place one sample inside a pyramid and the other in another location in the same room. Each 24 hours, observe the two samples and note differences in growth, appearance, or other physical factors.

### **4. *Bacteria growth:***

Crack two fresh eggs into separate clean saucers. Place one drop of saliva in each saucer in contact with the egg material. Place one saucer in a pyramid and the other in another location in the same room. Observe the appearances and physical attributes of each sample daily. The author does not recommend conducting experiments using dead animals because of potential health problems to say nothing of the reaction of neighbors or colleagues.

## Mind Machines You Can Build

### What If It Doesn't Work?

If negative results are forthcoming from any or all of the experiments suggested above, the first step is to try them again. Something (we don't know what) might have gone wrong in the preparations for the first tests. If negative results are obtained on the second try, give the pyramids to an acquaintance and have them perform the experiments. If the materials in suggested experiments #2, #3, and #4 show no significant differences, try running the experiments in a room heated to 90 degrees Fahrenheit. Try enclosing both samples by placing another saucer inverted over the sample saucers.

### Hypotheses:

When it comes to speculating why pyramids work as they appear to do, there are about as many hypotheses as there are investigators. Some hypotheses are, frankly, quite speculative.

In many cases, investigators utilize scientific terminology such as the word "energy" to describe something that may not be energy at all as physicists and engineers know it. This happens to be the case when it comes to discussing many of these strange machines and, in fact, unknown or "psychic" phenomena in general. One should always keep in mind that terminology is often borrowed and then used with perhaps a different

## Pyramids

meaning in mind because people have an overwhelming tendency to name the unknown, thereby giving them the belief that they partially understand it. It is not that investigators of strange phenomena are too lazy or ignorant to develop their own terminology because they often do, coining words to describe phenomena yet with little or no attempt made to carefully define or quantify these new terms.

The terms "energy," "power," "radiation," and other words pertaining to unseen and non-physical manifestations of the universe are most usually "borrowed" to describe the unseen, non-physical, and unknown phenomena associated with strange machines and other discrepancies in the Universe as we perceive it.

As scientific research proceeds as a result of the investigation of machines such as pyramids and others described in this book, you can rest assured that the new fields of scientific research will indeed develop their own jargon as factors and phenomena are identified and quantified.

Be that as it may, in the case of pyramid phenomena, it is obvious that the shape of the pyramid accelerates, retards, or concentrates some physical factor that results in change. Therefore, perhaps the word "energy" may be appropriate along with the word "radiation"



## Mind Machines You Can Build

which applies to the carrier of change-causing energy that creates action at a distance with no apparent intervening physical means.

In the matter of razor sharpening, the affected material is crystalline in nature. All metal alloys are. The crystalline structure of razor blade steel is very small. The atoms of iron, chromium, nickel, molybdenum, and other elements that make up the alloy are locked together by interatomic bonds in a lattice-like arrangement characteristic of a crystal. (Some crystals such as diamonds, salt crystals, gems, etc. are large enough to be readily visible.)

Research may confirm that water has a strong effect upon the interatomic crystalline bonds of razor steel. Water rather than comparatively soft protein material of hair may be the factor that dulls the sharp crystalline edge of a razor.

Scientists who carry out research in solid-state electronics know that nearly all the electronic phenomena associated with transistors, diodes, etc., take place at or on the surface of the crystalline solid-state material. On the surface of *any* crystal, especially those which have been cut from larger crystals, there are many loose or unattached crystalline bonds that have been physically severed in the cutting and/or polishing operation. The nature of crystal surfaces is still an area of intense scientific study about which little is yet known.

## Pyramids

However, it is known exactly how much energy is required to break a crystalline bond. In the microscopic world on the edge of a razor blade, there are many severed crystalline bonds created by the sharpening of the edge by grinding. This produces a surface with unsatisfied bonds that will link with anything, especially water. When a water molecule bonds to the crystalline structure of razor steel, it softens the steel. Research in this area has been done in Germany.

In the case of the bond that develops between a water molecule and anything else, the energy in the bond is extremely small, being approximately 1.0 to 1.5 electron volts (eV). Scientifically, this is the amount of energy acquired by an electron when accelerated across a potential difference of one volt. It is a very small amount of energy, amounting to  $1.602 \times 10^{19}$  to  $2.4 \times 10^{19}$  watt-seconds. That's 16 or 24 with 18 zeroes in front of it before you get to the decimal point.

This minute amount of energy is present all around us in the form of "sferics" or the discharges that take place between the Earth and its charged ionosphere. Lightning is an intense form of sferics. Sferics have a broad radio frequency spectrum; sferics are "noise" in the e-m environment. The minute energy of sferics could be easily concentrated or focused. There is indeed energy available because there's a potential difference of about 100 volts per foot in the vertical electrostatic field of the Earth. This means that there is an electrical difference of 600

## Mind Machines You Can Build

volts between the top of the head and the soles of the feet of a 6-foot person standing on the surface of the Earth. This potential difference is enough to be detected by suitable solid-state electronic devices and used in a simple autopilot to keep the wings level in radio controlled model airplanes, for example.

Most sferics come from thunderstorms, and there are about 300 thunderstorms in progress at any given moment in the Earth's atmosphere.

Very well, if there is enough energy present in the environment to break the crystalline bonds that may form between the ground sharp edge of a razor blade and water molecules, how does a pyramid shape affect this?

### Speculation:

1. The pyramidal shape is a resonator to the frequencies present in sferics. The bigger the pyramidal shape, the broader the bandwidth of sferics to which it is resonant.

2. It isn't necessary that a pyramid be made of metal to be an effective resonator of electromagnetic energy; it is only necessary that its *surface* have a *dielectric constant* that's different from the surrounding air because high-frequency radio waves (including microwaves) can be bent or reflected by anything having a dielectric constant different than the surrounding air. (If this were not so, radar wouldn't work.)

## Pyramids

3. A pyramidal shape can therefore serve as enough of a resonator of electromagnetic energy present in sferics to break the crystalline bond between the razor blade steel alloy and the water molecule, thereby restoring the original crystalline structure of the edge. (Eventually, because the pyramid shape cannot concentrate enough energy to break all the steel-water bonds, the build up of softer steel-water crystals on the edge causes the edge to become soft and dull.)

The apparent ability of a pyramid shape to dehydrate or mummify organic material may be due to the ability of the shape to concentrate, focus, or otherwise resonate with the microwave frequencies of sferics. *This can be measured with modem instrumentation.* And it should be. The various characteristics of purified (distilled) water placed in a pyramid shape should be investigated and measured to determine such gross and easily-measured factors as surface tension, which is a measure of the internal energy of the water molecules. It should also be possible to accurately measure the frequencies and intensities of electromagnetic radiation at various points inside a pyramid shape.

Much of this has been done, but little if it has been openly reported in the scientific literature because of the "peer review" process in which other scientists read and comment upon all submitted scientific papers. It's quite likely that most of this material has either been rejected with the derisive snort, "Huh? Pyramid power!"

## Mind Machines You Can Build

Ridiculous!" Or it has been accepted and lies buried unrecognized and uncorrelated somewhere in the enormous mass of wall-to-wall data that characterizes modern scientific research.

If the data isn't there, it should be gotten.

### Conclusions:

1. It works.
2. There may be a simple physical explanation for it if anyone bothers to look for it.

## **CHAPTER FOUR**

### **THE ENERGY WHEEL**

#### **Basic Description:**

The "energy wheel" is a small "wheel" or concentrically balanced object made from extremely light material. This is balanced horizontally on the sharp point of a needle or pin held in a vertical position by a suitable base plate. The operator places the device on a table, sits down, and places both hands cupped horizontally around the energy wheel. The objective is to "think" the lightweight

## Mind Machines You Can Build

wheel into rotating in the desired direction (clockwise or counterclockwise), to make it stop, or to make it stop and change direction without any visible physical contact with the wheel. The hypothesis of operation is often said to be *telekinesis* or the ability to change the physical position or motion of a material object by "thought waves" alone. However, there may be other factors at work, too.

### Historic Background:

Apparently, the first device similar (but perhaps differing in construction) to the energy wheel was called a "Biometre" and was developed by a Dr. Hippolyte Baraduc of France (no biographical data can be located). It consisted of a copper needle suspended horizontally by a thread from the top center of a glass dome. Beneath the dome was a horizontal dial marked off in circular degrees. The operator would cup both hands around the glass dome and, by "concentrated thought," rotate the needle left or right to the number of degrees marked on the dial.

A. M. O. R. C. (Ancient and Mystical Order of the Rose Cross, otherwise known as the Rosicrucian Brotherhood) developed a similar device consisting of a needle floating on water.

On page 222 of the 30 July 1922 issue of the famed British medical journal, *The Lancet*, Dr. Charles Ross authored an article entitled "An Instrument Which

## The Energy Wheel

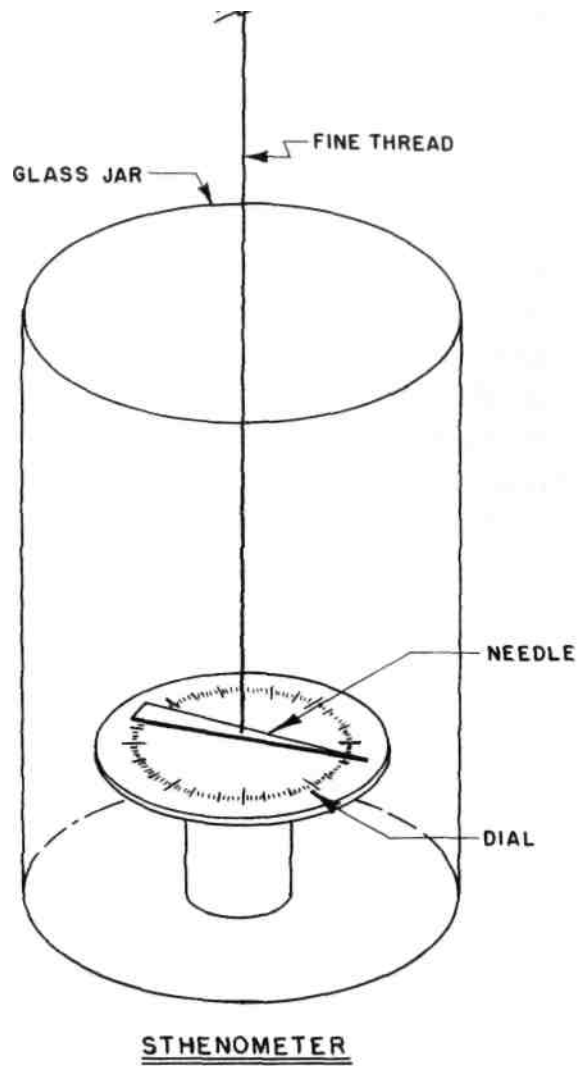

*Figure 4-1: An early version of the energy wheel was the sthenometer.*



## Mind Machines You Can Build

Is Set In Motion by Vision or by Proximity of the Human Body. " This device was also called a "sthenometer. " It consisted of a balanced needle suspended by a thread inside a surrounding transparent shield, preferably made of quartz (although glass was believed to be useable, too). A horizontal dial marked off in degrees was placed below the horizontally-suspended needle. The basic sthenometer is shown in Figure 4-1. It was claimed by Dr. Ross that the needle would respond instantly to the visual stimulus of a gaze or to the proximity of a human body. Why this device, described so carefully and completely in a respected medical journal, was not investigated further is unknown.

A Czech engineer, Robert Pavlita, developed a large number of similar "psychotronic generators" operating on "shaped power" following World War II. The Czechs have been very quiet about these devices and have revealed or published little that can be evaluated properly.

Flanagan (see previous chapter) combined his experiences in pyramid research with the devices of Ross and Pavlita to produce a "pyramid psychotronic generator" shown in Figure 4-2 and 4-2a.

Zenith TV engineer Gerald Loe developed a commercial version of these devices, calling it the "Energy Wheel®. " This little gem was introduced to me by Tag Powell in about 1980. The rotor consisted of a cross stamped from thin aluminum foil shown in Figure 4-3.

## The Energy Wheel

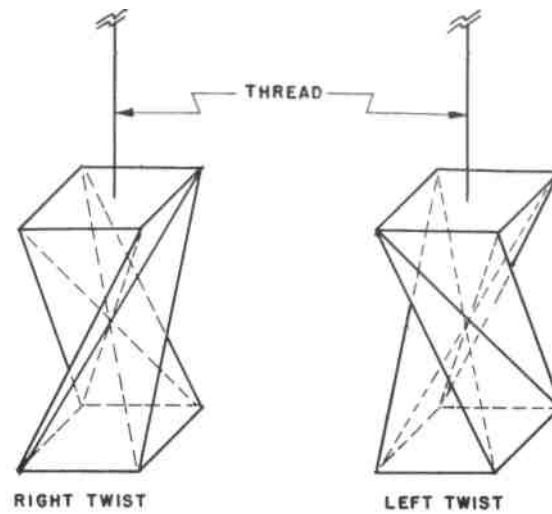
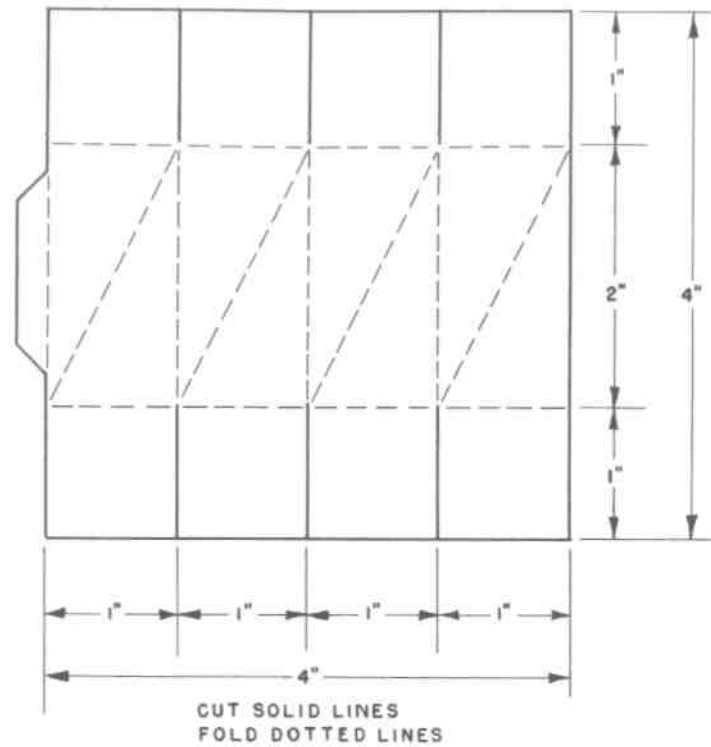

*Figure 4-2: Flanagan's "pyramid psychotronic generator," a version of the energy wheel. Depending upon how the paper template is folded, the generator can have a left- or right-handed twist.*

### Author's Experience:

The author first heard of the energy wheel device in about 1955 from John Woods Campbell, Jr. (1910 -1971), then editor of *Astounding Science Fiction* magazine published at that time by Street & Smith. Campbell's name will appear often herein because he was a technically-trained man who'd attended MIT and graduated

## Mind Machines You Can Build



*Figure 4-2A: Dimensioned template for cutting and folding a Flanagan "pyramid psychotronic generator" from a sheet of paper.*

with a degree in physics from Duke University. Campbell was interested in everything in the Universe, including things that were unexplained by science such as some of the machines described in this book. The Campbell

## The Energy Wheel

version of the energy wheel utilized a folded paper rotor similar to the one fully described below as the experimental device of this chapter.

The author's experiences with the Campbell energy wheel in 1955-1956 were mixed. Sometimes I could get it to work. Other times, I could not. The reactions of my friends and colleagues working in the rocket and guided missile area at White Sands missile testing range were also mixed. Therefore, I didn't pay much attention to this device again until Tag Powell gave me one of his energy wheels in 1980 (Fig. 4-3). I discovered I could cup my hands around the device and make it spin in both directions, stop, and reverse directions with great reliability and repeatability.

During a visit to my home by Tag Powell in 1983, we spent most of a day conducting various experiments with the energy wheel. The one we used is shown in Figure 4-3. If you don't want to make an energy wheel, you can buy the one shown. It's commercially available from Powell Productions, 11701 Belcher Road South, Suite 123, Largo, Florida 34643-5117.

We discovered that both of us could make it work equally well if we placed it under an inverted water glass, thereby shielding it from any air currents, including subconsciously-directed breathing, that might cause it to change its motion. But it would not work as well if placed under an inverted drinking container made of clear

## Mind Machines You Can Build

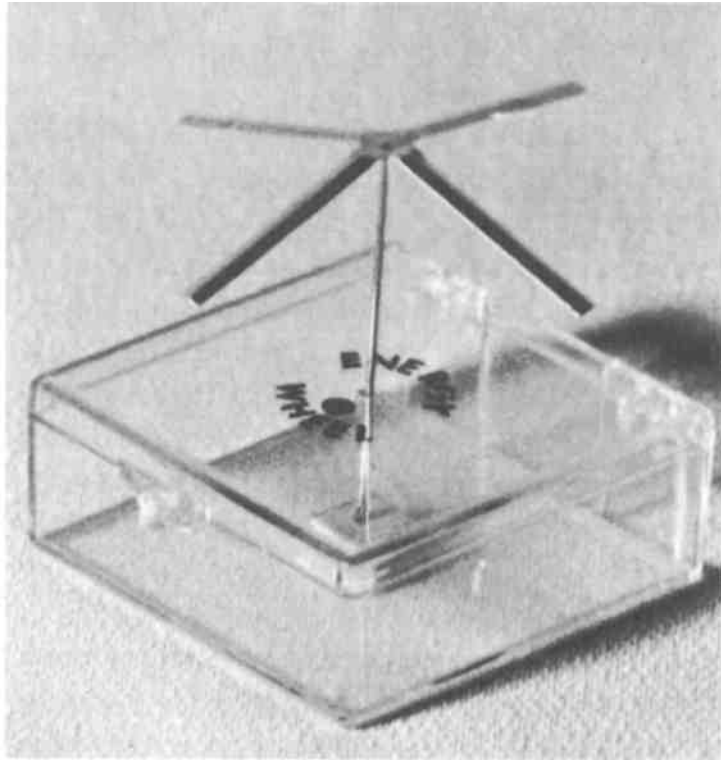

Figure 4-3: A commercially available Energy Wheel®.

polystyrene plastic. Both Powell and I could improve our capability to make the energy wheel move as desired if we coated our hands with a thin layer of Johnson's Baby Oil. It therefore appears that there's something that makes the energy wheel device operate, but further quantitative testing has not been done by the author. However, enough empirical testing was carried out to qualify it for consideration in this book.

## The Energy Wheel

### Instructions for Fabrication

It's ridiculously simple to make an energy wheel.

However, the device uses a *very sharp* needle pointing vertically upwards. It's possible to impale one's hand on this very sharp needle. *WARNING: Extreme care should be taken to insure that you don't impale part of yourself on the needle!* Do not leave the energy wheel assembled with the needle vertical and the wheel itself removed. In fact, once you've finished working with the energy wheel each time, disassemble it completely and put the needle in a safe place. Or place a rubber stopper, cork, or piece of clay atop the vertical needle point. Don't take chances and get stuck with the needle.

Obviously, don't leave the energy wheel assembled where small children may get to it, possibly play with it, and possibly get hurt by the sharp needle point.

The following materials are required to make an energy wheel:

1. A piece of writing or typewriter paper three inches square. The paper should be as thin and light as possible. Ordinary note paper is sufficient. Anything between 15-pound and 20-pound paper, as it is technically known, will work. Tissue paper is not recommended because it may be too thin to permit it to be folded or to retain its shape when folded.

Mind Machines You Can Build

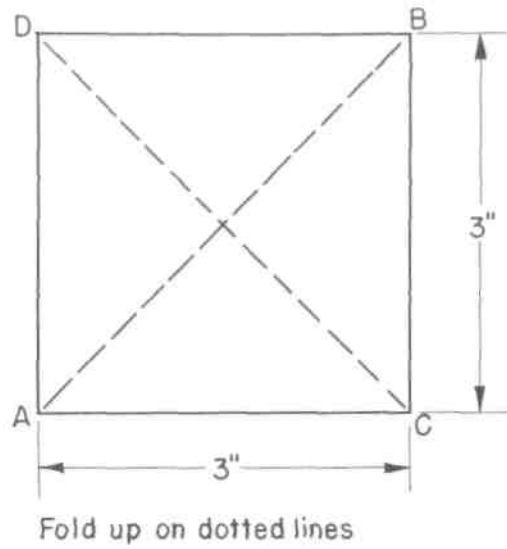

Figure 4-4: Energy wheel template.  
Make from light-weight typing paper.

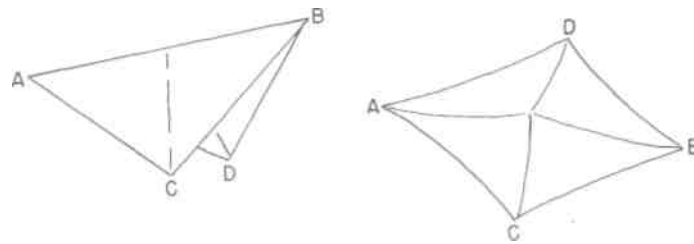
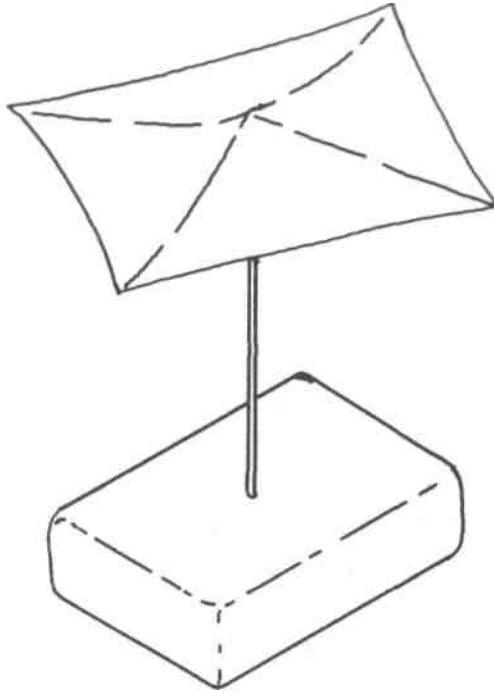

Figure 4-5: Folding the energy wheel template.  
Fold A-B and C-D down in the same direction  
to make a tent-like shape as shown.

## The Energy Wheel



*Figure 4-6:* Drawing of the completed simple energy wheel. For ease of operation, you may want to set it atop an inverted water glass.

2. A sewing needle about two inches long. The reason for using a needle is to have a sharp, low-friction needle-point bearing upon which the energy wheel can rotate.

3. A base to hold the needle vertical. You can use a kneaded rubber eraser, a lump of plasticene modelling clay, or a small block of balsa wood 1/2-inch thick and about 2 inches square.



## Mind Machines You Can Build

Other items you will need in order to conduct experiments include a glass drinking tumbler and plastic drinking tumbler, (both large enough to fit over the energy wheel), some baby oil, and a notebook and pencil with which to record the results of your experiments.

Cut the paper into a square three inches on each side. (Fig. 44) It doesn't have to be precisely square, but it will look better and balance better if it is. Use scissors, a single-edge razor blade, or a modelling knife along with a metal straight edge to insure straight cutting.

Fold the paper diagonally as shown (Fig. 4-5), then unfold it and fold it again from the two other opposed corners. Make both folds in the same direction so that you end up with a tent-shaped, partially-flattened pyramidal shape with a peak in the middle as shown.

Carefully insert the needle perpendicularly through the eraser or base piece until about 1.5 inches of the pointed end sticks out. Or mold a chunk of plasticene modelling clay around the eye end of the needle to hold it vertically.

*Gently* place the folded paper square on the point of the needle with the point nestled in the apex of the folds at the center of the square.

Your energy wheel is now completed(Fig. 4-6).

## The Energy Wheel

### Operating Instructions:

Find a quiet spot and place the energy wheel on a table. Make sure it's not in the draft of an air conditioning unit, window, or heater. Avoid any air currents because they make the experiments more difficult.

Sit down at the table facing the energy wheel. Cup both hands around both sides of it about a half-inch away from it. Keep your hands steady by resting your elbows and forearms on the table top. Look at the unit and think of it revolving. At first it may wobble. It may revolve first in one direction, then stop and start rotating in the opposite direction. Concentrate on movement in one direction.

Some people can make the energy wheel operate immediately. Others require a learning period ranging from several minutes to several weeks with regular sessions of five to fifteen minutes daily. (Other people can't make it work at all. ) Don't be discouraged if you can't get it to rotate. If you finally give up, try it on your friends. They might surprise you.

### Experiments:

There are several impromptu empirical experiments that you can conduct with the energy wheel once you learn to make it rotate.

## Mind Machines You Can Build

If there is any question in your mind concerning whether or not air currents are causing it to rotate, place an inverted glass drinking tumbler over it. Cup your hands around the glass and make it rotate in the enclosed space.

Once you have gained operational experience or taken experimental data with the energy wheel enclosed under an inverted glass tumbler, replace the glass unit with the polystyrene plastic one. Cup your hands around the plastic tumbler and make the energy wheel rotate.

The condition of the skin on your hands and palms may be a contributing factor in whatever causes the energy wheel to rotate. Try coating your palms with a thin layer of baby oil. Then remove the oil by thoroughly washing your hands and try again. Note any differences.

Try the energy wheel on several people, and keep accurate experimental notes on who can make it rotate, stop, and change directions best, and how long it took them to learn how to do it.

How do you learn how to do it? Nobody knows. You just have to keep trying until it happens (or doesn't).

There are many additional experiments that can and should be carried out with the various forms of energy wheels. The precise physical conditions of the environment and the subject should be instrumented, measured, and monitored for changes. These might include ambient air temperature near the energy wheel

## The Energy Wheel

(perhaps also above and below it), deep body temperature of the subject, surface temperature of both palms, the galvanic skin resistance of both palms, and the electric field present between the palms. Instruments to measure these parameters to great accuracy are available, but their cost may be beyond the means of the amateur experimenter. But the measurements need to be taken, the professional bioelectronic engineers apparently haven't done it, and therefore it's probably going to be up to the amateurs to forge ahead.

### What If It Doesn't Work?

You may not be able to get the energy wheel to do anything you want it to do. It may not rotate at all. It may rotate erratically. You may not have any conscious control over it at all.

I'll repeat what I've already said numerous times in this book: Some people can make it work, and some people can't. (Some people can play the trumpet, and others can't.) We don't know why this is so. But if some people can make it work (and this can be demonstrated repeatedly), we should try to find out why, shouldn't we?

### Hypotheses:

The first hypothesis that comes to mind concerning what makes the energy wheel rotate is: "thought waves," or psychokinesis, or telekinesis. One of the rea-

## Mind Machines You Can Build

sons why the rotating element of the energy wheel was originally fabricated with such low mass was the belief that such mental energy must be quite small and, since we couldn't move things that were obviously massive, perhaps "thought waves" could have some affect on bodies of extremely low mass. But just because someone can hang a name on a phenomenon doesn't mean that it's understood or that it really operates by something related to parapsychology (although it may, and that cannot be completely ruled out).

However, one of the basic principles of scientific investigation is called "Occams' Razor." This is a philosophical statement of natural law that comes from William of Ockham (c. 1280 -1349), an English schoolman who proposed the dictum *pluralites non est ponenda sine necessitate* ~ "multiplicity ought not to be posited without necessity. " In other words, choose the simplest possible solution or, in modern parlance, K. I. S. S. (Keep It Simple, Stupid.)

In applying Occam's Razor to the hypothesis that the action of the energy wheel is the result of psychokinetics or "thought waves," it must be pointed out that this hypothesis is complex because nobody yet knows what thought waves are or how they can be measured. Or can even agree that such things exist, much less on the reality of some attempts at detection and measurement of these phenomena. Therefore, until psychotechnology progresses to the point where we can hang numbers on

## The Energy Wheel

things and get everyone to agree on the basis of repeat-able experimentation, we'd better see if we can find other hypotheses with simpler explanations based on whatever part of the Universe we do indeed already understand well enough to have measured accurately.

This, in turn, brings up another principle of science: If you're going to propose a new theory, it must not only account for newly observed phenomena but must also allow for the existence of things that are already known. In addition, it must also predict phenomena that are totally new and unsuspected.

With these concepts in mind, let's look at some other hypotheses that might account for the action of the energy wheel. This may not be the only possible one nor the only one that meets the qualification of William of Ockham, but it's a point of departure that may make the energy wheel a little less hokey.

The hypothesis that the wheel is being unconsciously turned by selective unconscious direction of the operator's breath is put to rest by the experiment in which the rotor is operated while enclosed in an inverted glass water tumbler.

On the basis of results of experiments conducted by the author, the following hypothesis is put forward as a point of departure. It may not be correct. But it offers somewhere to start and something to be proven or disproven... or replaced by a better hypothesis.

## Mind Machines You Can Build

As discussed in the previous chapter, the planet that we live on functions because of electric, magnetic, and electromagnetic fields (and these three things are separate phenomena; see any elementary physics text). The planet Earth has an electrostatic field along with a magnetic field. So does every living creature on Earth.

A human being exhibits a change in electrical resistance of the skin which can be measured and which has been previously correlated with emotional states and action of the nervous system.

A human being is a complex electronic system with a skin that has a definite dielectric constant, which in turn can change because of emotional state (although there has been little work done and reported concerning this factor).

A human being also has an electrostatic field that is only partially the result of the body's immersion in the Earth's electric field.

Since it is already known that the voluntary (and involuntary) actions of the nervous system can alter the electric and magnetic characteristics of the human body in a highly localized manner - i.e., the galvanic skin resistance can be different at different parts of the body - it therefore follows that it is possible to voluntarily alter the electric charge on each hand or on different parts of a single hand.

One of the first experiments in electricity that a freshman physics student sees or carries out has to do with the electrostatic attraction of oppositely-charged bod-

## The Energy Wheel

ies and the mutual repulsion of bodies with the same electrostatic charge. We experience it daily with some plastic films that cling tenaciously to foods and other materials, including themselves; with dust and dirt that is electrostatically attracted to the front of a television set; with electrostatic dust precipitators both in homes and on factory chimneys; and with any cat that has had its fur rubbed vigorously.

It does not take much energy in the form of an electrostatic charge to make its presence known beyond the shadow of a doubt. And our own personal experience indicates that electrostatic forces, even small ones, can exhibit pronounced physical effects.

The energy wheel may function because of the operator's unconscious (but also, strangely, willed) ability to alter the electric field at different points of the palm of the hand or both hands. This should not appear to be a fantastic hypothesis since it is already well-known that a person can willfully alter the galvanic skin resistance and, therefore, the body's electric field.

Thus, the energy wheel could be nothing more than the bio-electric analog of the common, garden-variety, everyday electric motor. The common squirrel-cage induction motor used in fans and most small appliances is in itself an impossible device unless one understands alternating current theory. And it's interesting to note that alternating current theory and therefore the squirrel-cage induction motor depends entirely on a mathemati-



## Mind Machines You Can Build

cal concept known as "i" which is the square root of minus-1. This is a totally imaginary number that does not and cannot exist in the real Universe! Yet it is absolutely necessary in order to provide a theoretical foundation for the electrical power of alternative currents that today run our world.

The energy wheel may not have anything to do with "thoughtwaves," but only the mind's natural ability to alter the electrical characteristics of the skin. This hypothesis (which, by calling it a hypothesis, means that it is, at best, only an educated guess waiting to be tested and proved) satisfies the requirement that we continually wield Occam's Razor.

Viewed from the standpoint of an electrical phenomenon, the operating principle behind rotation of the rotor is straightforward in nature. The rotor is at all times at negative potential or charge, resting on an extension of the surface of the negatively-charged Earth. The rotor has four points or corners at which its negative electric charge is concentrated. If an operator can alter the electric field of one palm to make it positive while the fingers on the same hand are negative, the difference in electric charge would cause the rotor to turn.

This hypothesis can be checked by experimentation and measurement.

All rotors of all energy wheel devices seen by the author to date have been in cruciform (cross) shape or possessed some sharp points around their peripheries.

## The Energy Wheel

A critical experiment (the reader is invited to try it) is to determine whether or not a *circular* rotor (i.e., one without sharp corners) can also be made to rotate. The author has tried it and challenges the reader to perform the same experiment.

But why does a regular energy wheel appear to work well under a glass tumbler and not under a tumbler made of polystyrene plastic? Obviously, glass has a different dielectric constant than does polystyrene plastic. Can glass be given an electric charge more easily than plastic? The author hasn't investigated these areas yet. They are ripe for amateur experimentation.

From the professional or semi-professional scientific research standpoint, the human operator should be instrumented to measure galvanic skin resistance, skin temperature, and electric field potential and gradient at several locations on the skin, including critical points on the hands and palms. Solid-state electronic devices available today make such measurements possible where they were patently impractical if not impossible a mere twenty years ago. Such experimentation and measurement would serve to answer the question of how a person manages to operate an energy wheel and reveal the physical factors involved, but it will not answer the question of how a human being actually manages to change the electrical characteristics of the skin.

## Mind Machines You Can Build

### Conclusions:

The energy wheel is a simple device to make and, for some people, a simple device to operate. Its simplicity may mask a complex set of reasons why it works. However, its very simplicity permits a wide variety of experimentation by amateur scientists and offers professional researchers an opportunity to test and measure some physical factors that may be involved in its mode of operation. In the long run, both sorts of experimentation may reveal a great deal about the human mind and body that is currently either unknown or assigned to the realm of the fantastic or the province of charlatans. However, the simple fact that a large number of otherwise ordinary people can make this simple device operate indicates that it is not mystical in nature. Modern scientific procedures and instrumentation can be applied in an attempt to learn the mechanics of operation. Furthermore, proto-sciences such as parapsychology need not be invoked to provide an explanation of why it works.

## CHAPTER FIVE

### PENDULUMS

#### **Basic Description:**

In some respects, the two different pendulum types described in this chapter are similar in operation to the energy wheel of the previous chapter. Both consist of very light masses suspended from supports by thin threads . It is claimed that the action of volitional thought can cause the pendulum to move. In the case of the pendu-

## Mind Machines You Can Build

lum, however, it appears to offer "yes-no" answers to questions. It also appears that it can be used to indicate the direction to a wanted object.

The first type of pendulum is hand-supported. It is undoubtedly the easiest to operate. However, the possibility of minute, subconscious movements on the part of the operator casts considerable doubt on any claim that a hand-supported pendulum is a "amazing mind machine" operating because of as yet unknown operational principles.

The second type of pendulum is supported from a rigid point such as a lampshade edge, desk lamp, or simple tripod support made from wooden dowels. The independently-supported pendulum eliminates the possibility that the human operator could control its swing by unconscious and minute finger, hand, and/or arm movements. The independently-supported pendulum may also be operated under a transparent cover to eliminate the possibility that air currents might affect its swing.

The operator "thinks" or concentrates on the pendulum, asking a question that can be answered in a "yes-no" manner. By previous agreement, the swing of the pendulum to and away from the operator may mean "yes" while a swing from left to right may mean "no." The operator must announce prior to the start of the experiment which direction of motion signifies affirmative and which indicates the negative response.

## Pendulums

To use the pendulum as a locator similar to detector rods, the operator asks the pendulum to swing in the direction of the object whose location is being sought. There is, of course, an ambiguity in the fact that the unknown object can be located in either direction that the pendulum swings - i.e., if the pendulum swings in a north-south plane, the object could be located either north or south of the operator. Some operators appear to be extremely adept in getting the pendulum to swing in a most unusual fashion when in the *locator mode*: they can cause the pendulum to swing from its vertical rest position to a displaced position in the direction of the object, then cause the pendulum to swing between the vertical rest position and the displaced position.

### Historical Background:

"The Magic Pendulum" has its origins lost in the mists of prehistory. It has long been a device used by wizards and shamans. Just because a device has a long history doesn't mean that we, with our immensely increased wisdom growing from a centuries-old legacy of scientific progress, should both scoff at and ridicule such devices that appear to have no rational explanation in terms of the Universe *as we know and believe it to be*. All our ancestors for several hundred thousand years not only believed in such "magic" devices but conducted their affairs in accordance with what these devices told

## Mind Machines You Can Build

them. We know beyond the shadow of a doubt that their reliance on these devices could not have been foolish and/or disastrous because our ancestors lived and thrived and produced progeny culminating in ourselves. If all our ancestors were fools and we of the modern "scientific" age are so smart, this would mean that the Mendelian Laws of genetics and heredity are plainly nonsense. But we also know for a fact that these principles of biotechnology are indeed valid, true, and (most important) pragmatically workable. Ask any breeder of horses or dogs or any farmer who relies on hybridized crops. Perhaps our forebears were not quite the stupid clods we tend to believe, but possessed some evidence that strange machines such as the pendulum did indeed have some validity, even though they didn't understand why they worked and therefore placed them in the "magic" classification.

Human beings are also eminently practical. If it doesn't work, it's discarded. If it seems to work most of the time or enough of the time to make it useful, it's used until something better is discovered or developed.

Very little research work or further development has been undertaken with this extremely simple machine. It exists today in nearly the same form as it has for uncounted centuries.

However, the social milieu has changed. In most of the world today, you will not be burned at the stake as a witch for experimenting with such devices as the

## Pendulums

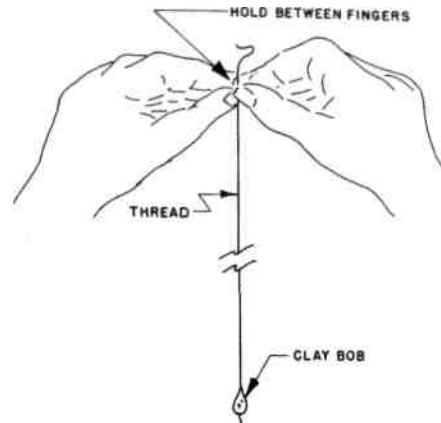

*Figure 5-1:* Hand-supported pendulum. Rest your elbows on a table to steady your hands.

pendulum. (However, there are still some locales in the United States where you would be well advised to be somewhat circumspect in such experimentation simply because America has all types of people in it, including those who are still very superstitious, fearful, and violent.)

### Author's Experiences:

I do not remember when I first tried using a pendulum. It may have been when I was about twelve or thirteen years old and became fascinated by a ouija board, which led me to experiment with some of the other



## Mind Machines You Can Build

devices of "witchcraft and sorcery" that my juvenile colleagues brought forth from time to time. Many of these machines were "discovered" and subsequently experimented with because we were at that age and that level of scholastic sophistication where we were being introduced to the Scientific Method and to the mysteries of the Universe revealed by our resident scholastic magician, the junior high school science teacher, one Donald John Obee at Cheyenne Mountain School in Colorado Springs, Colorado. One thing I can say for Mr. Obee: He made science and technology fascinating, fun, and also frustrating enough to encourage me out of curiosity to continue to be interested in science and technology for the rest of my life. The mere idea that I didn't have to be captive to the whims of nature but could, if I understood enough about it, manipulate the Universe so that I could do magic things like fly in the air and go to the moon got me hooked at an early age because, even then, I felt I had been jerked around enough by a capricious Universe. I can make a hand-supported pendulum work. But I don't always know whether or not it gives me the correct "yes-no" answers because I haven't used it enough for that purpose. The pendulum requires that the operator play the game of "Twenty Questions. Doing this often takes longer to answer a question than to either *go* look it up in a suitable reference book or think it through and work it out myself. And I've never really been certain that I wasn't unconsciously making the pendulum swing

## Pendulums

the way I wanted it to swing. I often have much the same feeling about detector rods but in the case of that device, there is absolutely no question in my mind that I am not making those rods swing for the simple reason that the response is so strong.

I can also make a self-supported, glass-enclosed pendulum swing. I don't know why, although, as you will see later, I do indeed have a hypothesis.

Observations of other people operating pendulums of both sorts shows that about 80% of volunteer subjects can make a hand-supported pendulum do something while about 50% of people can make the self-supported pendulum operate. I don't know why.

### Instructions for Fabrication:

This is one of the simplest of all mind machines to build and operate.

The following materials are required:

1. A thumb tack, paper clip, or a minute pinch of plasticene modelling clay to use as a pendulum bob.
2. A spool *of* sewing thread for the pendulum itself; this can be made of nylon, silk, polyester, or any other material.
3. Cellophane tape to use for affixing the upper end of the pendulum to a support.

## Mind Machines You Can Build

4. A pendulum support; this can be nothing more sophisticated than the shade of a desk lamp, study lamp, or table lamp; or the lower edge of a kitchen or bathroom cabinet.

5. A glass water tumbler and a polystyrene plastic water tumbler (this last item optional).

Cut an eighteen-inch length of thread (longer if your pendulum support is higher than this distance from the table or other horizontal surface; in fact, the longer *the pendulum, the more sensitive it will be*).

Tie one end of the thread to the pendulum bob - the paper clip or thumb tack - or mold a bean-sized lump of plasticene modelling clay around the end of the thread.

No further fabrication is required for the hand-supported pendulum.

An independently-supported pendulum can be made by taping the free end to the lamp shade so that the pendulum bob swings freely just above the surface of a table.

The pendulum can also be fabricated inside the water tumbler by taping the free end of the pendulum support to the inside of the bottom of the glass so that the pendulum bob swings freely inside the tumbler when it is inverted. For a pendulum that's more sensitive, use one of those tall conical beer glasses.

## Pendulums

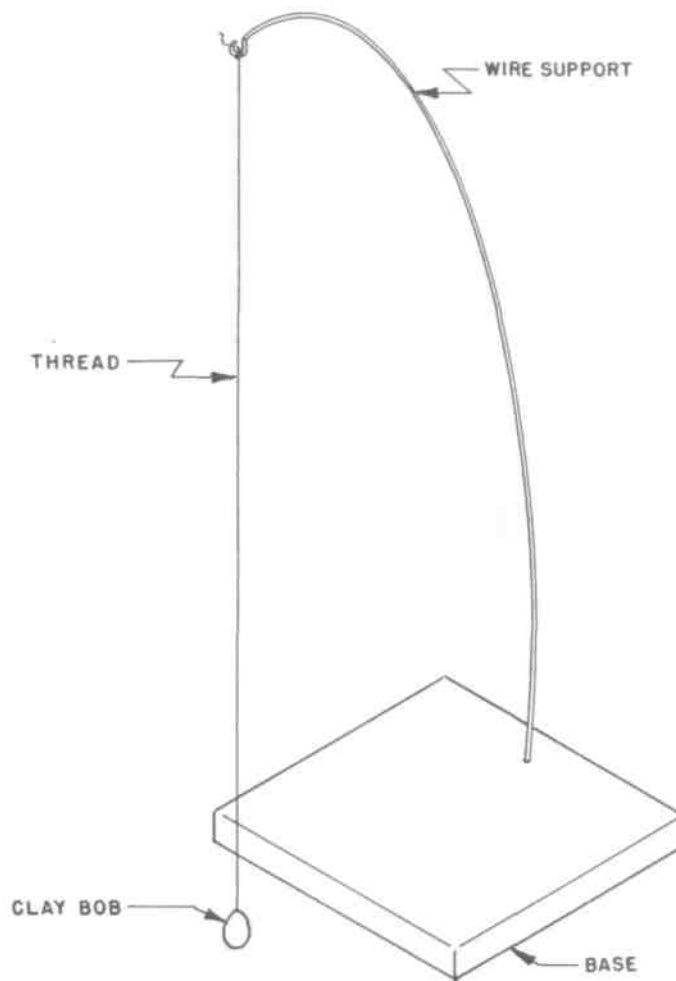

*Figure 5-2: An independently-supported pendulum. Any method of supporting the pendulum will work. The longer the pendulum, the more sensitive the pendulum will be.*

## Mind Machines You Can Build

Serious investigators may wish to fabricate a series of pendulums having bobs of differing sizes, weights, shapes, and densities; supports made from various thicknesses of thread and thread materials; and enclosures consisting of cylindrical glass and lucite plastic tubes with suitable supports or caps on their upper ends from which to suspend the pendulum.

But the common, parlor-variety pendulum for "quick-and-dirty" empirical experiments can be made in satisfactory form with the very simple materials detailed above.

### Operating Instructions:

#### *Hand-supported pendulum:*

Seat yourself in a comfortable chair at a table in a location free of air currents from air conditioners, heaters, fans, and drafts from open windows. Take the free end of the pendulum support thread between the fingers of your hand, and place both hands together to steady one another. (Fig. 5-1) Place your elbows on the surface of the table to steady them. Adjust the length of the pendulum until the bob swings just clear of the table top. Determine the direction of the pendulum swing in yes-no response to your questions. It is normal in most

## Pendulums

European cultures for the "yes" response to be a swing toward and away from the body of the operator while a "no" response is a side-to-side, left-right swing.

Determine what you wish to know. The questions must be phrased so that they can be answered as "yes" or "no." This often means framing a series of questions to arrive at the desired answer. People who are experienced at playing "Twenty Questions" will find it easier than someone who is not.

Most people will get a pendulum response when it is operated in this hand-supported mode.

### *Independent suspension mode:*

Affix the free end of the pendulum thread with cellophane tape to an overhanging support (Fig. 5-2) such as a lamp shade or shelf in a location reasonably free of air currents from air conditioners, fans, heaters, and drafts from open windows. Adjust the pendulum length so that the pendulum bob swings freely just above the surface of the table or counter. Seat yourself comfortably in front of the pendulum. With your hands, still the swing of the pendulum that may have been produced in the act of suspending it. Once the pendulum is hanging quietly, place your arms on the table and cup your hands

## Mind Machines You Can Build

around the pendulum bob about three to six inches away from it. Novices may discover that it is easier to work the pendulum with their hands cupped closer to it.

Operate the pendulum as described for the hand-supported unit. Frame and ask your questions in the same manner.

### Experiments:

If the hand-supported pendulum experiment works for you, try the independently suspended pendulum.

Once you have obtained results from the independently-suspended pendulum, try making it swing *without* cupping your hands around the pendulum bob.

As in the experiments with the energy wheel in the previous chapter, try coating your palms with a thin film of baby or bath oil to change the electrical characteristics and dielectric constant of your skin. Or wash your hands thoroughly and completely to remove as much natural skin oil as possible.

If you suspect that air currents from your breath, someone else's breath, or ambient air currents in the room are the cause of pendulum action, perform the enclosed pendulum experiment by suspending the pendulum inside an inverted glass water tumbler. (Fig. 5-3) Cup your hands around the outside of the tumbler and repeat the basic operating instructions given above.

## Pendulums

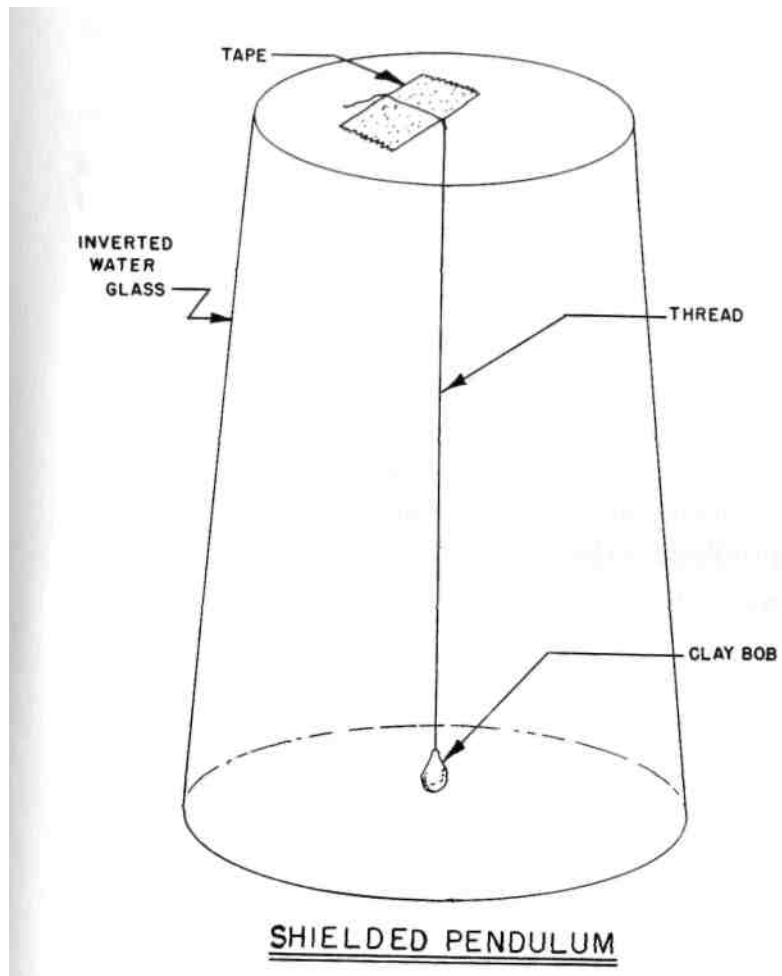

*Figure 5-3:* To eliminate any possibility of air currents swinging the pendulum, mount it inside an inverted water tumbler as shown.



## Mind Machines You Can Build

If the pendulum works inside an inverted glass tumbler, try the experiment with the pendulum inside the polystyrene plastic water tumbler.

The longer the pendulum support thread, the *more* sensitive the pendulum will be to any disturbing force. Try extending the length of the pendulum thread and note the results.

The heavier the pendulum bob, the *less* sensitive the pendulum will be to any disturbing force. Replace the paper clip or thumb tack with a blob of plasticene modelling clay. Continue to decrease the amount of clay used for the bob to increase the sensitivity. You will, of course, eventually reach the point where the mass of the clay is insufficient to keep the pendulum thread taut as well as permitting the pendulum to swing due to the relative increase in the ratio between forces on the bob and forces on the supporting thread.

Try a critical experiment: Arrange an independently-supported pendulum in a location where the operator can cup his hands around it *but cannot see the pendulum*, (a sheet of cardboard will do nicely). A serious investigator may wish to fabricate a transparent plastic cylinder to enclose the pendulum, then paint one side of the cylinder so that it is opaque. With the pendulum thus hidden from the operator, an observer then notes and records the actions of the pendulum in response to

## Pendulums

questions asked verbally by the operator. The results should be compared with those obtained when the operator could see the pendulum.

### What If It Doesn't Work?

If you get no response from the hand-supported pendulum, you are certainly in the minority. However, increase the sensitivity of the pendulum by decreasing the mass of the pendulum bob as detailed in the experimental section above.

It often helps to place a flat sheet of paper horizontally on the table below and directly underneath the pendulum bob. On the paper, draw a cross. Place the word "yes" at both ends of the vertical bar of the cross and the word "no" at either end of the horizontal bar of the cross. This may assist you in concentrating and in keeping fully in mind the direction the bob should swing in order to provide "yes-no" answers.

If it doesn't work at all, put it away and try it again later. We don't know what the effect of various moods, biorhythms, emotions, state of rest, etc. has on the operation of a pendulum. Could be you're just having a bad day because we all have those.

If after many tries you can't get the hand-supported pendulum to work for you, try it on a friend.

## Mind Machines You Can Build

The same advice holds true for the other pendulum experiments. However, for the independently-suspended pendulum, try changing the electrical nature of your palms by either washing your hands or by coating them with baby or bath oil...or both in sequence.

Then, again, as I've pointed out time and again in this book, you might not be able to get the pendulum to work at all. And we don't know why.

### Hypotheses:

As in the case of the energy wheel of the previous chapter, we need not invoke bizarre hypotheses involving undiscovered radiations or waves. We are again dealing with phenomena that can probably be explained reasonably well with the science and technology already known to us.

As an important aside, however, it is also likely, however far less probable, that there is indeed something new and hitherto unsuspected involved in the operation of the pendulum. I want to make it clear that I do not wish to sound dogmatic when I present hypotheses. It could very well be that it all happens because it pleases the Great God Bog as part of his arcane if whimsical way of running the Universe for his own amusement. But I really doubt it. I could be wrong, of course. One must keep an open mind when dealing with these machines....

## Pendulums

When Occam's Razor is applied to the hand-supported pendulum, the simplest explanation is that the operator is consciously or unconsciously affecting or modulating the innate natural nervous tremor, the "noise" in the human nervous system, possessed by everyone, thereby causing the pendulum to swing.

However, there are other problems that are not addressed or answered by this simplest and most straightforward of hypotheses. How does the operator know the answer? What if the question doesn't involve an answer with a high content of wishful thinking? What if the pendulum taps the super-hyper-ultra-conscious or even the subconscious? What if it's tapping "subconscious" or "racial" memories? If it is indeed doing these things, it's doing them better, a lot faster, and far more positively than any psychiatrist or psychological technique I've ever known.

Obviously, in spite of a simplistic hypothesis that resists the cutting edge of Occam's Razor, there must be something more to the hand-held pendulum. I don't know what it is. But it deserves more investigation.

With respect to the independently-suspended pendulum, almost every freshman physics student is aware of the demonstration or experiment in which a light object such as a bit of paper or cork is attracted to a rubber or glass rod which has been rubbed gently with silk or cat's fur. This is an exhibition of electrification. In

## Mind Machines You Can Build

the previous chapter, the first law of electrostatics was stated: Objects that are similarly charged repel each other while bodies with unlike charges attract each other.

In addition to various objects that have been given an electrostatic charge by various means, the equipment used to demonstrate this principle usually consists of a small, light object suspended from a thread as a pendulum. It is surprisingly easy to give an object enough electrostatic charge to affect another object such as a suspended lightweight pendulum bob.

We also saw in the previous chapter that the human body carries an electrostatic charge on the surface of the skin and that the action of the nervous system can change the polarity and strength of this electrostatic field. In all people, it is an unconscious phenomenon, which means that it is accomplished without the person being aware of it in much the same manner that people are unaware of their breathing or heartbeat. However, like breathing or the heartbeat, it can be voluntarily and willfully controlled.

Therefore, the operational hypothesis here is nearly the same as that proposed for the energy wheel: The human mind causes the nervous system to change the electrostatic charge on the skin of the hands in such a way as to cause the independently-suspended pendulum to swing. When the charge on the right palm is plus and the other palm minus, and if the pendulum carries a minus charge, it will swing toward the right hand. The

## Pendulums

mind then causes the electric charge on both palms to reverse, in turn causing the pendulum to swing in the other direction. To cause the pendulum to swing toward and away from the experimenter, the charge on the heel of both hands must be the same while that at both fingertips the same.

It would not take a very strong change in electrostatic charge of the skin of the palms to cause the pendulum to swing.

Here again, the physical factors can be measured as in the energy wheel tests. Solid-state electronic measurement sensors exist that will detect and determine the electric field.

But, again, this hypothesis begs the question...and it is a most important question: How does the operator know how to make the swinging pendulum answer the question for which the operator has no conscious answer?

And, again, claiming that the pendulum triggers racial memories or other deep-seated psychological factors raises even more important questions that basically involve the elusive "how": How can the simple pendulum accomplish this so easily when it requires hours, weeks, or even months of intense psychological therapy, treatment, or investigation to dig these things out otherwise?

## Mind Machines You Can Build

### Conclusions:

Here is a very simple mind machine whose operating principles appear to be both obscure and complex. But the hypotheses may only appear to be complex because the operating mechanism is still totally unknown. The device works and will indeed answer questions with a reliability that has been shown to be much better than random chance.

It is also a device that lends itself to experimentation by amateurs. The instrumentation involved in measuring the physical factors involved is not complex or expensive. Furthermore, the instrumentation is totally within the current state of the art.

We are perhaps confronting two separate phenomena with the hand-supported pendulum and the independently-supported pendulum. But, with the present level of knowledge in this area, there did not appear to be much to be gained by considering them separately.

## CHAPTER SIX

### THE HIERONYMOUS MACHINE

#### **Basic Description:**

The Hieronymous Machine is covered by United States Patent No. 2,482,773 granted September 27, 1949 to Dr. Thomas Galen Hieronymous, Advanced Sciences Research & Development, Inc., P.O. Box 127, Lakemont, Georgia 30552. It is also covered by Canadian patent 486,008 and British patent 663,978.



## Mind Machines You Can Build

According to Dr. Hieronymous, the device is intended for the detection and analysis of minerals utilizing a new aspect of the physical universe discovered by him which he calls "eloptic radiation."

The machine uses a simple pickup coil, an optical prism rotated as a tuning device, an electronic amplifier, and an output sensing device best described as a "tactile detector."

The basic elements of a Hieronymous machine are shown in Figure 6-1. The mineral or metal sample is placed next to a pickup coil which is attached to a terminal inside the machine. "Eloptic radiation" from the terminal is refracted through a rotating prism where it is picked up by another probe. This "signal" is then transmitted through an electronic amplifier circuit whose output goes to the detector, a coil of wire located underneath a flat plate of glass, lucite, plexiglas, polystyrene, or other plastic.

The operator places the "sample" next to the pickup coil, turns a knob which rotates the prism as well as a graduated dial, and strokes the flat plate of the tactile detector with their fingertips until the surface of the plate "feels different." At this point, the machine is "tuned" and, if the dial has been pre-calibrated so that the dial setting for various elements is known in advance, the operator can determine the presence of that element in the sample.

## The Hieronymous Machine

The Hieronymous machine described herein can be used to determine the nature of the elements in the sample. A more advanced version described in the basic patent will permit the operator to determine the relative percentage of each element in the sample by means of an attenuator circuit not described herein. Therefore, *the Hieronymous machine is basically an analytical device.*

However, it does not appear to operate according to any known principles of physics.

In fact, it does not appear that it should work at all. But it does.

The fact that it does indeed work has been independently confirmed by many investigators who have built the device according to written instructions without personal instruction from or contact with the inventor and who have obtained independent results confirming the inventor-discoverer's claims.

The Hieronymous machine is not one of the simpler strange devices. To build it in this form requires tools, parts, and some knowledge of modern electronics (but not much if you can follow instructions). However, there are simpler versions of the device that will be discussed in detail later.

## Mind Machines You Can Build

### Historical Background:

As noted above, this device was first patented by Dr. Hieronymous in 1949, which indicates that he had been working on it for several years, perhaps as much as a decade or more, prior to that date. There appears to be no prior patented art utilizing his hypothesis of "eloptic radiation."

Full details of the Hieronymous machine were published in Volume LVII Number 4, the June 1956 issue of *Astounding Science Fiction* magazine with an illustrated science article written by the editor, John W. Campbell, Jr.

There have been no published articles in national or international magazines available to the general public since that date. However, Dr. Hieronymous is a founding member and a director of the United States Psychotronics Association which meets regularly to discuss and demonstrate devices such as the Hieronymous machine and which publishes material on these devices.

### Author's Experience:

The publication of the details of the Hieronymous machine in *Astounding Science Fiction* magazine in 1956 and 1957 prompted me to construct one because all of my academic education and my in-the-field training and experience told me that the device couldn't possibly work

## The Hieronymous Machine

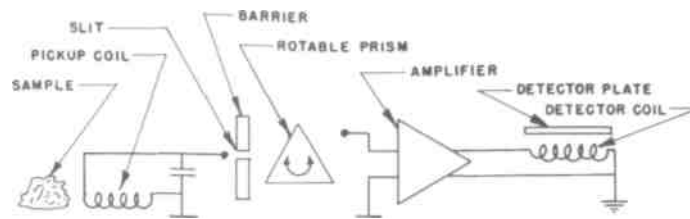

*Figure 6-1: Block diagram, Hieronymous machine.*

at all. I had been corresponding with John W. Campbell, Jr. since I was also writing science fiction stories during the evenings; I was employed full-time as a general engineer at the U.S. Naval Ordnance Missile Test Center at what was then White Sands Proving Ground (now the White Sands Missile Range), New Mexico. In the course of this correspondence with Campbell, we engaged in the usual sort of intellectual techno-scientific argument that Campbell enjoyed instigating. I believed Campbell to be wrong in several matters, and the opportunity to *prove* him to be wrong in the case of the Hieronymous machine was too great to ignore.

I was greatly surprised when my Hieronymous machine worked exactly as Campbell had written in both the magazine and in letters. I was a confirmed skeptic (and still am), yet here was a device that worked

## Mind Machines You Can Build

as predicted, and I had built it from written instructions and without any personal contact whatsoever with the inventor.

In the ensuing months, I learned that my wife could not get a response from the device (she can't work detector rods, either), but more than 80% of the rocket and guided missile scientists and engineers at White Sands who tried it got a response. The most interesting response came from Dr. Clyde W. Tombaugh, the astronomer who had discovered the planet Pluto in 1930 and who was at that time involved in searching for small natural satellites of the Earth. Dr. Tombaugh reported, "The change in touch sensation on the plate is there, but to me it is just at the threshold of sensation, much like seeing fine details on planetary surfaces."

I have since tried my Hieronymous machine with many people and have confirmed that between 80% and 90% of those who try it get a response.

In all cases, I have not instructed the operator concerning what sort of change could be anticipated in the feeling of the tactile detector plate since this could amount to suggestion that might prejudice the results. The instructions given are as follows: "Tune it like a radio by turning this knob. Stroke this plastic plate here. Tune it until the plate feels different. Don't worry; you won't get an electric shock because that plastic is thick

## The Hieronymous Machine

enough to be insulation against more than 50,000 volts. Don't ask me what it should feel like. Tune it and tell me.

People have reported that the plate suddenly felt slick, that it felt sort of like tar, that it felt like someone had suddenly spilled orange juice over it, that it suddenly felt like it was covered with thick grease that was slippery yet sticky, that it felt furry like a kitten, that it suddenly became warm, that the plate suddenly began to tingle, or that its shape suddenly felt like it had changed from a flat plate to a bowl. No two people appear to get precisely the same reaction. One operator removed her fingers from the plate with the comment that it suddenly felt like her fingers were about to become immovably stuck to or glued to the plate. Some reactions have been strong. Others, like that of Dr. Tombaugh, were on the threshold of sensation.

From time to time, I have had to perform maintenance on a Hieronymous machine. These details will be discussed later.

### Instructions for Fabrication:

Construction of a Hieronymous machine as described in this chapter requires a great deal of ingenuity, access to a good electronics parts store, a reasonably well-equipped workshop, the necessary tools, and skill in building things. However, it can be built in less than ten

## Mind Machines You Can Build

hours. It was much easier to build a Hieronymous machine back in 1960 or 1970 because people then were not used to building things from kits in which all parts were supplied and complete, step-by-step instructions included. Furthermore, many mail order electronic parts supply companies have gone out of business since 1975, making it difficult for enthusiasts to build electronic equipment if they don't live in a city or town with a good electronic parts store. Unfortunately, Tandy Radio Shack doesn't carry many of the necessary components, although many parts can be located there. There are two ways to locate a well-stocked electronic parts firm: (a) check the Yellow Pages of the telephone book under the category "Electronic Equipment & Supplies ~ Dealers," or (b) find a local amateur radio operator or "ham" and ask him.

The original Hieronymous patent describes an electronic device using vacuum tubes. It's increasingly difficult to obtain the necessary parts for vacuum tube electronic equipment these days because nearly all electronic gear now uses either transistors or integrated circuit chips. However, based on the author's experience, it shouldn't make any difference whatsoever whether the Hieronymous machine is made with vacuum tubes, transistors, or integrated circuit "op amps" (operational amplifiers).

## The Hieronymous Machine

An analysis of the Hieronymous patent circuitry indicates that the electronic amplifier is a "broad-band" voltage amplifier with a circuit gain of 20 to 100. Since it's a voltage amplifier, it cannot produce enough radio frequency energy to even warm the fingertips, much less cause any shock hazard in the well-insulated tactile detector. Furthermore, the original patent shows a system that has an operating frequency from about 500 kiloHertz to 1.5 megaHertz, which is roughly the frequency spectrum of AM broadcasting (500 kHz to 1500 kHz). This frequency range presents absolutely no problem whatsoever to nearly all modern transistors and integrated circuit op amps.

Although it may seem that it's no help at this point, nothing about the Hieronymous machine seems to be critical from an electronics standpoint. You can build a perfectly good Hieronymous machine almost by "freelancing it," building any sort of amplifier system providing that the basic elements of the block diagram of Figure 6-1 are followed.

The pickup coil can be wound with 7 turns per inch of #18 wire on the 1.5-inch diameter cardboard core from an exhausted roll of bathroom tissue. Make the coil about 2 inches long. Solder the leads of a 0.01 microfarad capacitor across the coil to produce a pickup sensor resonant at about 500 kHz.



## Mind Machines You Can Build

The "eloptic shields" shown in Figure 6-1 can be either aluminum sheet or polyfoam; it doesn't seem to make much difference.

Finding the prism and its rotating dial may be the most difficult task *of* making the Hieronymous machine. Any sort of small glass prism will do. Edmund Scientific Corporation (101 East Gloucester Pike, Barrington, NJ 08007) has a large selection of glass prisms available in a wide variety of sizes and at low cost. Get an *Edscorp* catalog and order the prism that's the right size for your Hieronymous machine. You will have to find the place where radio hams buy their parts in order to get a "National Velvet Vernier Dial" assembly upon which to mount the prism and thereby turn it so that its position can be read and noted on the vernier dial.

Although the original vacuum tube amplifier circuit of the original Hieronymous machine is shown in Figure 6-2, you may find it easier to build the transistorized version shown in Figure 6-3 or even the op amp version shown in Figure 6-4. Parts for the various versions are available from electronic supply stores. The advantage of the transistorized and op amp versions is that they can be operated using flashlight batteries for power, eliminating the need to build a 250-volt DC power supply required for the vacuum tube version.

The output of the amplifier is wired to the detector, which is another component you'll have to make from scratch. (One of the difficulties of technical pioneer-

## The Hieronymous Machine

ing is the fact that you have to build so much from scratch because there isn't much in the way of prefabricated equipment available.)

The detector can be made from two sheets of 1/4 inch thick polystyrene or lucite plastic which can be obtained from a plastic supply house (although some hobby shops may have materials that can be substituted). Again, find such a company in the Yellow Pages of the telephone book. Two sheets of plastic, 4 inches square, are held apart by a piece of cardboard 1 inch in diameter. Using plastic cement or (carefully!) one of the acrylonitrile super glues, assemble the two plastic sheets on either side of the central cardboard core. When the cement has thoroughly set, wind a coil of about 40 turns of #22 enameled copper wire in a spiral around the core.

One side of the coil assembly becomes the tactile detector plate. The output of the amplifier is connected to the coil.

The entire assembly should be built into an aluminum or plastic chassis box. These are available at Tandy Radio Shack or an electronic parts store. Again, since there are many ways to assemble a Hieronymous machine and many different size boxes available, make it your own way. The only thing to remember is the *relationship* between the various components should be maintained as shown in the block diagram. The position of the components with respect to one another doesn't seem to be as important as maintaining the integrity of

## Mind Machines You Can Build

the relationships between the basic parts. It should be assembled in such a way that the pickup coil is on the side of the box so that samples can easily be placed near it. The tuning knob should be in a position where it can easily be turned with one hand while the tactile detector plate is in a horizontal position where it can easily be stroked with the fingers of the other hand at the same time.

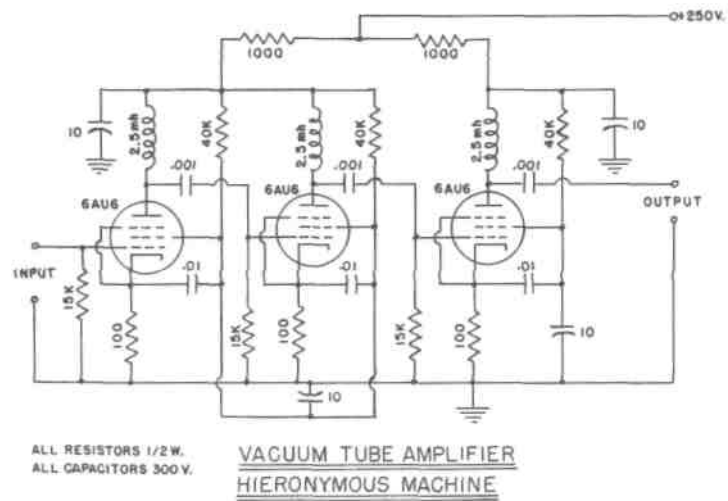

Figure 6-2: Circuit schematic, vacuum tube amplifier for a Hieronymous machine.

## The Hieronymous Machine

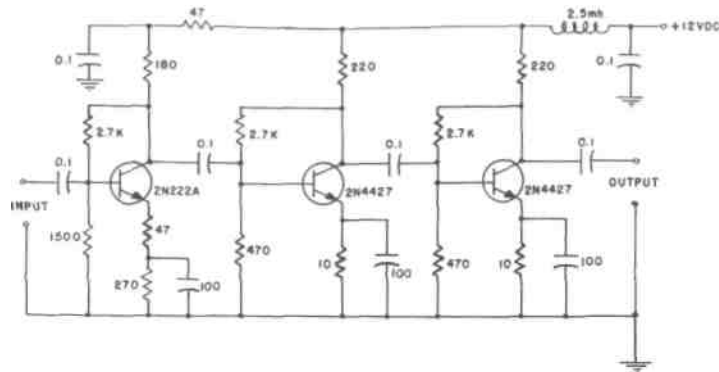

Figure 6-3: Circuit schematic, transistorized amplifier for a Hieronymous machine.

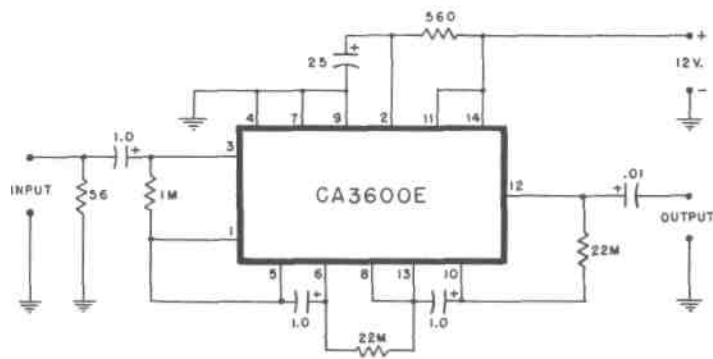

Figure 6-4: Circuit schematic, integrated circuit amplifier for a Hieronymous machine.

## Mind Machines You Can Build

### Operating Instructions:

Obtain several pieces of metal of different types. An aluminum kitchen pan can be one. A large bolt can be another.

Place the Hieronymous machine on a table and turn it on. Put the metallic sample next to the pickup coil.

With one hand, slowly turn the tuning knob.

With the other hand, gently stroke the surface of the tactile detector with the fingertips.

Turn the tuning knob and stroke the tactile detector until the surface of the detector plate feels different.

Turn the tuning knob back and forth to "zero in" on the tuning point where the different feeling of the detector plate is at its maximum.

Note the reading of the vernier dial in a notebook for future reference.

Several points on the tuning dial may cause the detector plate to feel different. Note the dial reading of each point.

Try it again with a different sample next to the pickup coil.

Note that these instructions specifically state that the surface of the detector plate will feel "different." We have done a reasonably good job in developing the English language to describe sight and sound sensations. Describing a tactile sensation is extremely difficult. It's similar to attempting to describe the sensations of taste or

## The Hieronymous Machine

smell. Try describing the difference in flavor between a peach and a banana, for example. On the other hand, we can describe the appearance of a peach well enough to differentiate it from a banana.

As noted above, many people report widely different types of tactile sensations when using the Hieronymous machine.

### Experiments:

One of the first experiments that should be carried out with the Hieronymous machine is to *calibrate* it. It should exhibit a different dial reading for each different element in a sample. Therefore, obtain samples of reasonably pure elements such as iron, aluminum, copper, zinc, silver, gold, etc. Most iron items these days are alloys of two or more elements in addition to iron. The same holds true of aluminum. Reasonably pure copper is available in the form of copper piping. Coins should not be used as calibration sources because today they are often made of alloys rather than pure copper or silver. A piece of sterling silver tableware can be used, and 24-carat gold jewelry will provide a good calibration point for gold.

Each material should exhibit the maximum tactile sensation at a given place on the dial. These should be recorded for future reference.

## Mind Machines You Can Build

Each person should experience the maximum tactile sensation for, say, gold at the same place on the dial as other people.

Once the machine is calibrated, a series of experiments can be run by covering the dial and by hiding the sample inside a cardboard box. The operator should continue to obtain a maximum tactile signal at the same place on the dial even though the operator cannot see the dial or know what the sample consists of.

Electrical measurements should be made during the operation of the Hieronymous machine. The electrical characteristics at various places in the circuitry should be monitored with both oscilloscopes and high-impedance voltmeters. Some experimenters have reported that there were *no changes* detectable in the electrical characteristics of the circuitry when operators were getting maximum responses from the tactile detector. This needs to be confirmed by several investigators. I've confirmed it, but much better and more sensitive instruments exist today than when I did it in 1957.

Dr. Hieronymous claims that his "eloptic radiations" can be captured by a photograph and that the detector will react to a *photograph* of the sample just as it does to the sample itself. Without reporting on my own results in such an experiment, this is one that should be carried out because on initial presentation it sounds far more impossible and implausible than the Hieronymous machine itself.

## The Hieronymous Machine

The Hieronymous machine should be tried by a large number of people because only 80% to 90% of those who try it will get any response whatsoever from it. The collection of data on who can operate it and who cannot is a valid experiment, especially if it is carried out in such a way that each person is given exactly the same instructions prior to trying it. It may also be useful to record the operator's verbal opinions *after* the initial operating attempt is made, not before. It may be useful to know who steadfastly refused to believe that the machine would or could work before it was tried, and who among this group actually got a response.

The Hieronymous machine forms the starting point for an entire series of fascinating experiments regarding the effects of prior opinions and beliefs upon the results. Many people approach a device such as the Hieronymous machine with an open mind. How many of these get a response? Others approach it with skepticism, and many of these get a response which surprises them. Others approach it with the attitude that it must be a fraud and cannot work...and it doesn't. There are many ways to conduct such an experiment.

The manner in which the Hieronymous machine is presented to the novice operator may have a great deal to do with the nature and strength of the response. For example, if it is presented in an environment that appears to be scientific and technical (i.e., in laboratory-like surroundings or in a science fair, for example), it may



## Mind Machines You Can Build

elicit a higher percentage of responses than if it is exhibited in connection with astrology, the occult, or mysticism.

The Hieronymous machine is an *excellent* project for a science fair because such an exhibition permits the collection of a large amount of operational data from spectators.

In fact, the Hieronymous machine may be far more important and valuable as the vehicle for learning how to design, carry out, and evaluate experiments.

### What If It Doesn't Work?

Mine didn't until I found the badly soldered electrical connection. Check for this.

Again, the continuing advice for this sort of response is: Try it on someone else. Or try it tomorrow.

Or give it to someone else to use and to experiment with the proviso that data be kept and reported.

The Hieronymous machine appears to work for such a large percentage of people who try it that it's very unusual for a person not to get a response from it.

## The Hieronymous Machine

### Hypotheses:

In order to build and operate a Hieronymous machine successfully, it is necessary to use the fundamental proposition of the scientific method: In studying a hypothesis, it must be accepted wholeheartedly and the experimenter must follow through without quibbling. The existence of Dr. Hieronymous' eloptic radiation must be accepted as a *working hypothesis* regardless whether or not you believe it to be utter nonsense. You have the perfect right to be skeptical and to reserve judgement, but you do not have the right to reserve action on the logical consequences of the hypothesis while you're claiming to make a test of it. If the test fails, you may then claim the working hypothesis is invalid. If the test works, you can then either accept the hypothesis or attempt to form a hypothesis of your own. In both of the latter situations, the hypothesis must not invalidate what we already know to be true and workable, and it must even predict some phenomenon that would not otherwise have been anticipated.

Dr. Hieronymous designed and built this machine to apply his hypothesis of "eloptic radiation" to the detection and analysis of minerals. He states that eloptic radiations are emitted continuously by all elements, that each element emits a different sort of eloptic radiation, and that these eloptic radiations can be manipulated interchangeably either as optical phenomena or electric

## Mind Machines You Can Build

currents. His device operates on the principle, he states, that the eloptic radiations can be picked up by electrical components, passed through lenses and prisms, and amplified electrically.

My own opinion based on building and testing several different types of Hieronymous machines is that Dr. Hieronymous' hypothesis is incorrect. Or perhaps his terminology is imprecise. To me as a person educated in physics, " radiation" is a specifically defined physical phenomenon having specific characteristics involving wavelength, frequency, propagation speed, energy content, ability to function either as a particle or as a wave, and precisely defined relationship with matter. It may also behave in accordance with the principles of quantum mechanics. The principles of "eloptic radiation" conflict with many of these known, proven, and *used* principles of radiation. For example, the tactile detector of the Hieronymous machine makes absolutely no sense either in terms of the eloptic radiation hypothesis *or* standard physics. Therefore, my *hunch* is that whatever makes the Hieronymous machine work is not radiation.

But I don't know what it is.

### Conclusions:

The Hieronymous machine works even though we may not understand why.

## The Hieronymous Machine

Dr. Hieronymous has a valid patent on a device that is truly scientific in nature. By this, it is meant that a person reading the patent and following its statements can construct a device which performs as predicted in the patent. Furthermore, others who have built the device can describe it in writing in such a way that third parties who have seen neither the patent nor have had individual contact can also repeat the experiment successfully. There is no mysticism about it. One does not have to seek the personal enlightenment of gurus "skilled in the art" nor undertake mystical or magic activities in order to achieve the predicted results.

Furthermore, although the "eloptic radiation" hypothesis of Dr. Hieronymous may or may not be valid, the device apparently operates on a new principle that has been discovered and applied by Dr. Hieronymous. But that new scientific principle is still unknown because it probably is not the one he discusses in his patent.

The Hieronymous machine may or may not be useful as an quantitative and qualitative mineral analyzer, but it is certainly a device that is amenable to experimentation by both amateurs and professionals alike in attempts to gain an understanding of how and why it operates, which in turn may shed new light on hitherto unsuspected new fields of scientific knowledge.

The Hieronymous machine, like many other mind devices, reveals that with all our knowledge we still don't know everything there is to know about the Universe.

## Mind Machines You Can Build

Like many other devices, it will stimulate people to try to learn these new secrets. And, in common with these other devices, it shows that there is still plenty of room for progress in science.

Most of all, it's an enormous challenge to those with inquiring minds.

## CHAPTER SEVEN

### SYMBOLIC MACHINES

This chapter is a departure from the rigorous format of the previous chapters because the devices and experiments to be discussed here and in the remainder of the book are of a somewhat different nature than the amazing mind machines discussed thus far.

Furthermore, it's necessary to break the continuity in order to present some background information and describe some experiments that are *very* unusual and *highly* controversial but which tend to confirm some of the hypotheses that follow.

## Mind Machines You Can Build

It's also necessary because the amazing mind machines of the remainder of the book are even more unbelievable than those discussed thus far.

Be prepared for and be advised that what is discussed henceforth is pure and simple magic, keeping in mind Arthur C. Clarke's admonition and Robert A. Heinlein's observation.

It is not witchcraft, and one should not be afraid of the modern consequences of the instructions (which are not commandments) of Exodus 22:18: "Thou shalt not suffer a witch to live." Apparently, the old Hebrew word meaning "poisoner" was mis-translated as "witch." And it's probably not a bad idea to get rid of people who run around poisoning other people. But if we do indeed agree that (a) magic is a technology we don't yet understand, (b) we do not yet know everything there is to know about the Universe, (c) the Universe operates according to orderly principles that can be discovered and learned, and (d) the primary task of "science" is to make a series of successively more accurate approximations to reality, then it must follow that there is no such thing as witchcraft, sorcery, and the "arcane arts," only science that isn't science yet.

But what we are talking about, is not mysticism because it can be described in the English language, it does not require personal training or contact to learn, and it can be duplicated by a large percentage of the population. Therefore, although it is not mysticism, it is

## Symbolic Machines

still magic because we do not know the scientific principles involved nor understand the technology. This doesn't make what we are to discuss any the less real.

Thus far, this book has required an open mind of the reader. Henceforth, it demands it. One of our themes has been, "You don't have to believe or have faith, but you cannot simply snort 'impossible' and turn away. You are challenged to test and draw conclusions based on that solid data rather than from emotional reactions based on what someone else may have told you is true."

The purpose of this chapter is to address, attempt to prove, and to discuss the following:

### *Hypothesis Number One:*

Symbols have real, physical effects on human beings.

### *Hypothesis Number Two:*

Relationships between symbols can change or alter the nature and intensity of these effects.

Note: One does not have to be symbol-minded to conduct the experiments that will either prove or disprove the validity of these two hypotheses.



## Mind Machines You Can Build

For untold centuries, people have believed in the power of symbols and the relationships between symbols.

The emotional effect of symbols on people is real. People have killed other people because of symbols or in the process of defending symbols. Some examples of this sort of symbol: the cross, the star and crescent, the stars and stripes, the hammer and sickle, the double-headed eagle, Britannia, John Bull, Uncle Sam, Mother Russia, the rising sun, the swastika, *la belle France*, the stars and bars... One of these symbols or its equivalent is certainly capable of stirring emotion within you.

People work for symbols - i.e., pieces of paper bearing the symbol \$, for example. A piece of paper with the symbols "\$1000" on it along with other authenticating symbols will certainly give you power over other people in such a way that they will willingly do what you want them to do. The same sort of power resides in a rectangular piece of embossed sheet plastic, often coated with a strip of selectively magnetized iron oxide material, which can be carried by the dozens in your pocket or purse. Can any voodoo rite exercise this sort of power as regularly or as reliably with little or no training on the part of the person in possession of the symbol?

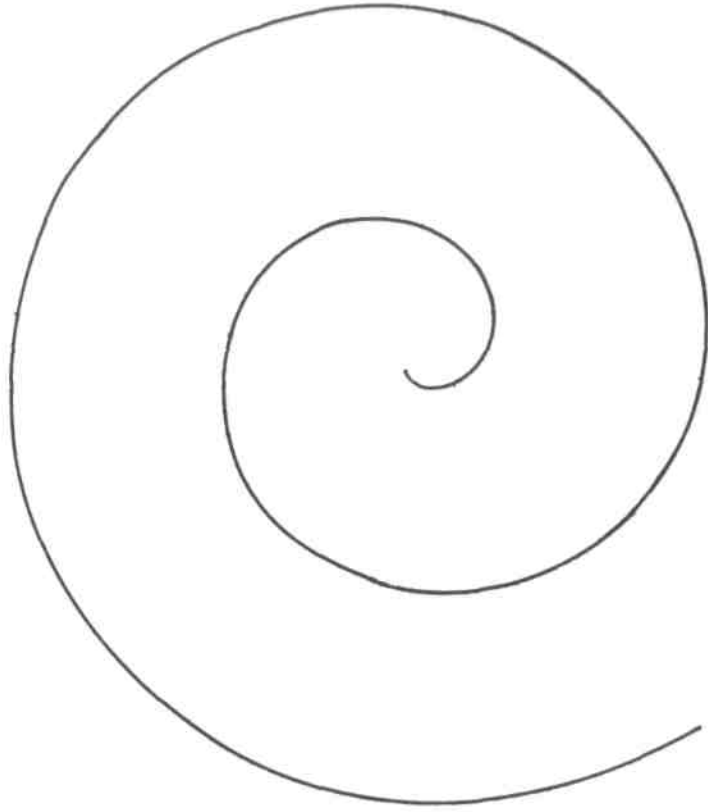

*Figure 7-1: Left-handed spiral.*

## Mind Machines You Can Build

People believe in and depend upon symbols such as the curious ones you are viewing on this page which, strung together and given meaning in your mind, form verbal words in your brain which in turn are symbols standing for something real or unreal.

Symbols give people power over other people in other ways, too. Few uniformed policemen or deputy sheriffs would go on duty without their shield or star badges. Do you realize all the power over the lives of people that a single silver star on a shirt collar possesses, to say nothing of a crimson flag with a single star flying from a short staff on the fender of a car? Or three cloth chevrons sewn on both sleeves of a shirt?

There are few barns owned by my Pennsylvania Dutch relatives in Pennsylvania and Ohio, that do not bear symbols which are repainted annually. No Portuguese dingy or fishing trawler puts to sea without symbolic eyes painted on both sides of the bow to ward off evil. Do they do any good? That doesn't matter. What does matter is that people believe those symbols have power, and because of that the symbols indeed do: they have power over the people who painted the symbols there in the first place.

The relationships between symbols are also very powerful. If you don't think so, wait until your Cousin George dies intestate and leaves a five million dollar estate. What is your relationship on the company organizational chart to the vice president and what power

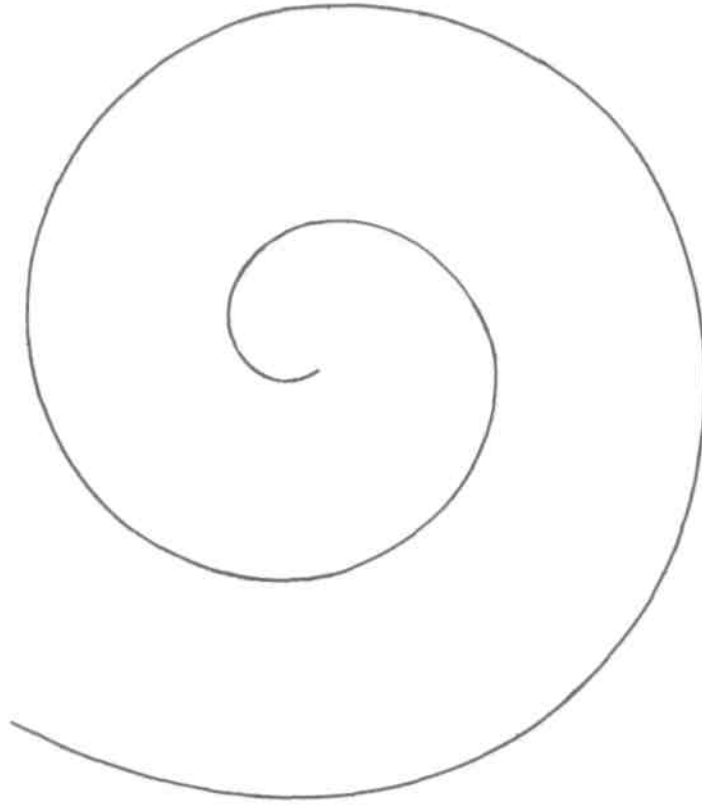

*Figure 7-2: Right-handed spiral.*

## Mind Machines You Can Build

does that relationship, which exists only on paper, have over your life? Which is closer to the United States, Great Britain or Cuba? Diplomatic protocol officers have as their life work the analysis of precisely such relationships. The position and relationship to other symbols of the simple mark "." (or "," in some countries) can make the difference of orders of magnitude. There is no question about it: The relationships of both symbols and the world are real and have immense importance.

With this background in mind, let's conduct a few experiments that tend to verify the physical power of symbols over the human body.

### Symbols and Physical Strength:

The purpose of this experiment is to demonstrate the effect of two different but similar symbols on the physical strength of the muscles of the body.

Any person can conduct this experiment, but it takes two people to do it. There's nothing harmful about it, but it can cause some long-term bursitis-like discomfort if the experiment isn't, in effect, "turned off."

The materials required are amazingly simple and readily available.

The procedure is also simple and can be conducted by anyone. Furthermore, the experiment is a valid scientific one because it can be described in writing,

## Symbolic Machines

carried out with no prior training, and produces vivid and repeatable results in 99.999999999% of all cases. (There is nothing in the Universe that can be counted on 100% except death and taxes, of course.) Statistical analysis isn't necessary. However, like any experiment, even firmer results can be obtained through the use of double-blind techniques.

On a sheet of paper, draw with a ball-point pen or a pencil a spiral such as shown in Figure 7-1. Accuracy, size, or artistry are not important. What *is* important is the *direction* of the spiral. As shown, it is a *left-handed* spiral.

On another sheet of paper, draw another spiral like the one shown in Figure 7-2. Note that this is the mirror image of the spiral of Figure 7-1. It is a *right-handed* spiral.

One person (the subject) stands and extends his/ her arm (either arm may be used) horizontally out from the body with the palm of the hand facing down. (Fig. 7-3)

The other person (the experimenter) stands facing the subject, places one arm on the subject's shoulder and the other arm on top of the subject's extended arm over the wrist.

The experimenter then pushes down on the subject's arm at the wrist. The subject must resist this force with the muscles of the arm. The experimenter pushes down until his actions overcome the resisting

## Mind Machines You Can Build

muscle force of the subject. Both persons should note the amount of force required to move the arm and to resist the movement.

With his free hand, the subject now picks up the piece of paper with the *left-handed* spiral drawn, on it and holds the paper to his chest.

The muscle-force experiment is now repeated. It should be slightly easier for the subject to resist the downward force the experimenter is exerting on the outstretched arm.

The subject then puts down the paper with the *left-handed* spiral, picks up the paper with the *right-handed* spiral, and holds the paper to his chest. The muscle-force experiment is repeated.

The results are usually quite dramatic. The subject is almost totally unable to resist the downward force being applied to his arm by the experimenter.

For some reason unknown to us at this point in time, the act of holding a *left-handed* spiral symbol against the chest results in a weakening of the ability of the person to resist a force being applied to the muscles of his body.

The experiment should be repeated by holding the *left-handed* spiral again to the chest to confirm to both the experimenter and subject that the apparent weakness was not caused by fatigue brought about by the initial part

## Symbolic Machines



Figure 7-3: Performing the muscle strength test.

of the experiment. The reapplication of the *left-handed* spiral symbol to the chest results in a regaining of the muscle strength.

The experiment should also be repeated using the subject's other arm, again to confirm that this phenomenon doesn't depend upon using the right or the left arm.

The results of this experiment are always striking. Furthermore, they are repeatable.



## Mind Machines You Can Build

The only caveat that applies to the experiment is this: The final step in the experiment *must* be to "turn off" whatever factor is weakening the arm muscles. The final step *must* be to have the subject hold the *left-handed* spiral to his chest while the experimenter repeats the arm displacement. I discovered the hard way the consequences of performing the *right-handed* spiral experiment last. Within a week, the muscles of my arm became quite sore and I had trouble raising my arm above the horizontal because of dull muscle pains that I initially mistook for bursitis. When I mentioned this to the experimenter who'd been working with me, we realized what was probably taking place and then "turned off" the experiment as described above. It was most dramatic because the bursitis-like pain disappeared *immediately*. If this is "psychosomatic" as many critics have claimed, it is certainly the quickest, easiest, and cheapest way to get rid of bursitis that I've ever encountered because that pain was as real as any I've ever perceived.

Why does the holding of a scrawled symbol again the chest produce such dramatic and striking results?

We don't know. It shouldn't work. But it does. It qualifies in all respects along with the rest of the machines herein as part of "protoscience," something which we can demonstrate but cannot yet explain. In short, it is pure and simple magic.

## Symbolic Machines

The amount of force exerted on the subject's arm can be both controlled and measured by using an experimental device designed along the lines of a Nautilus machine and instrumented with sensors which will measure the exact forces involved. This can and should be done. It may be done only by amateur experimenters because few if any professional medical researchers are inclined to believe that this is a real experiment.

### The Sugar Test:

Another dramatic experiment can be conducted in the same manner as the spiral experiment described above.

However, the symbols and the experimental materials are different.

Instead of using the pieces of paper with symbols drawn thereon, obtain a small package of cane or beet sugar such as can be found in most restaurants. It doesn't make any difference whether the material in the package is cane or beet sugar. Both are basically dextrose.

Perform the initial arm displacement test with the subject holding nothing.

Then perform the test again with the subject holding the small package of sugar against his chest. (*Note: Be sure to "turn off" this test by holding a left-handed spiral symbol against the chest and repeating the arm displacement.*)

## Mind Machines You Can Build

The results are as dramatic as the right-handed and left-handed spiral symbol tests. The act of placing the package of sugar against the chest acts in the same manner as placing the right-handed spiral symbol against the chest.

Why?

We don't know. But we do know that the dextrose in cane or beet sugar is a *right-handed molecule*.

The sugar test is a perfect experiment for double-blind procedures. A test series can easily be devised using unmarked but coded packets of identical size and appearance, which contain sugar and a "placebo" material that looks and feels like sugar but which is a non-handed molecule. Neither the experimenter nor the subject should know which is which. This series should determine whether or not any pre-knowledge of the nature of material has any effect upon the results.

Another series of experiments should be conducted with only the experimenter knowing what is in each packet.

And yet another series with only the subject knowing the contents.

The purpose of these experiments would be to determine whether or not there is any suggestibility involved or any information passing between experimenter and subject by non-verbal or sub-threshold signals. Some people may claim that the information is transmitted by thought waves" or telepathy; if so, this is probably what

## Symbolic Machines

is called both a "critical experiment" as well as an "elegant experiment." If the design of the experiment is done in such a way that non-verbal but visual/auditory signals can be ruled out as causative factors, then it's probably the best experiment yet devised to demonstrate telepathy. (Except the "back scratching test" - i.e., if someone can *always* scratch your back exactly where it itches without being told, it's probably because of some manner of telepathy.)

However, I would be greatly surprised if telepathy has anything to do with it. Occam's Razor must be applied. There is probably a simpler explanation of hypothesis than would be required if the totally unknown factor of telepathy were postulated.

But I don't know what it is.

And I may be wrong in my honing of Occam's Razor.

But three tilings are certain:

1. The spiral experiment is a dramatic demonstration of the physical effect of pure symbols on the muscle strength of the human body.

2. All these experiments show that the relationship between symbols and the human body is a factor. The symbols and the sugar packet not held in close relationship to the human body have no apparent effects, even though they may be in plain view of both subject and experimenter during the conduct of the tests. The symbols must be in *intimate physical relationship with the body*.

## Mind Machines You Can Build

3. These tests are of such a nature that they are amenable to "rigorization", they involve methods and procedures that can be instrumented for measurement of the physical factors involved and designed to be conducted under the most rigorous protocols. Mechanical devices can be used to apply the required forces, eliminating the human factor of the experimenter. The scope of these experiments can be expanded - for example, do other muscles in the body react in the same manner?

Some of the experiments are so simple in nature, conduct, and protocols that they are prime candidates for high school science fairs. Yet none of them are so complex nor are any of their extensions or "rigorizations" so difficult that they cannot be carried out by amateur investigators with limited means. They can also be carried out, of course, by professionals in research facilities. But, since the basic knowledge of these experiments has been around for at least several decades and since no professional organization has yet looked into them, it seems unlikely that anyone except amateurs will exhibit the willingness to undertake them.

These amateurs, of course, may well become the non-amateur expert professionals of a totally new and unanticipated field of scientific endeavor. Every field of science was started by amateurs (by definition) and usually with the scoffing (if not the opposition) of the established professionals. The reasons are easy to discern. Many professionals acquired their expertise at a young

## Symbolic Machines

age and at great personal expense; many therefore will unconsciously oppose anything which remotely threatens their expertise and/or position. They would prefer to see scientific progress made slowly and carefully in such a way that it doesn't threaten them, that they can adapt to it, and perhaps that they can be tenured or retired before their expertise becomes obsolete.

But every great advance in mankind's knowledge of the Universe has come about as the result of a bold, daring generalization.

The "daring generalization" here is that symbols and their relationships have a definite physical effect upon human beings.

The amazing mind machines that will now be discussed are further examples that tend to strengthen the basic hypotheses stated earlier in this chapter.

What is different is that *you don't have to believe* in anything in order to get them to work, just as belief played absolutely no role in the simple physical experiments described in this chapter. Belief apparently has little or nothing to do with whether or not the devices work or the experiments succeed. This is the most important factor that separates what we are doing from mysticism.

However, the fact that it works and is apparently real (if not understood) doesn't make it any the less puzzling, frustrating, and/or disturbing.

## Mind Machines You Can Build

## CHAPTER EIGHT

### THE SYMBOLIC HIERONYMOUS MACHINE

#### **Basic Description:**

This strange machine is strange indeed. It is a Hieronymous machine consisting entirely of symbols save for a few moving physical parts needed to rotate the prism, the sensor coil, and the tactile detector. It is typical of many inexplicable but operable devices made up of symbols representing physical objects. These symbols are arranged in the same relationship as the physical



## Mind Machines You Can Build

devices in the original machine. It produces the same result as the non-symbolic machine with about the same degree of reliability and repeatability. Furthermore, it operates with no apparent input of energy as energy is presently understood in the physical sciences. However, it may not operate under any of the presently-known principles of physical *or* psychological sciences.

The symbolic Hieronymous machine consists of the standard pickup coil or sensor of the non-symbolic machine, the tactile detector plate, a means to rotate a symbolic prism to tune the device, and all other elements of the machine reduced to inked drawings on cardboard connected with symbolic electrical wires made of thread. It is enclosed in a standard electronics parts box. The model for use during experiments also contains an AC power cable and plug, a small transformer, a switch, and a pilot light, none of which are connected to any of the symbolic circuitry inside the box.

The device behaves essentially as the original non-symbolic Hieronymous machine does. Many people have tried it and have gotten results fully equivalent to the results obtained on the non-symbolic Hieronymous machine.

### Historical Background:

When John W. Campbell, Jr. began working in 1955-1956 with the original Hieronymous machine described in Chapter Six, he discovered that it ceased to

## The Symbolic Hieronymous Machine

work if a vacuum tube burned out - if the filament broke, if the glass or metal envelope broke, or if the tube somehow ceased to function effectively as an electronic device. He also discovered that it wouldn't work if one of the wires came un-soldered or broke.

But he accidentally discovered during an experimental run with a volunteer subject that the Hieronymous machine worked perfectly well even though he'd completely forgotten to plug it into the 120-volt AC wall socket. In other words, the Hieronymous machine would operate without any power supply at all!

Campbell wrote, "I can't defend, or even describe, the process by which I arrived at the hunch, "These things depend upon relationship-as-a-thing-in-itself." Campbell then took that hunch as a postulate, did some deductive thinking, and carried out some physical equipment tests. If relationship only was involved, then the presence or absence of a power supply in the Hieronymous machine should make no difference because it wouldn't change the relationship of the parts. But a burned-out tube or a broken connection *would* make a difference; it would alter the relationship of the parts.

He went directly to the purest form of this postulate. He reasoned that the closer the experiment was to a pure symbol, the less objective reality there would be and the more nearly a perfectly pure relationship would exist. "The letter A scratched in the mud is a symbol; it has precisely the same symbolic properties as a letter A

## Mind Machines You Can Build

made of reinforced concrete and standing forty feet high. The material object structure has zero significance; only the relationship pattern has meaning."

He built a Hieronymous machine leaving out most of the material objects of the system by substituting symbols which maintained the same relationship to one another. Because he was also a realist and felt that the mind-set of "impossible" or "possible" might strongly affect the initial results a subject experienced, he added the totally non-functional but equally totally misleading on-off switch and pilot light. Externally, therefore, the symbolic Hieronymous machine looked completely normal save for the unusual tactile detector which, on the basis of his previous experiments with the non-symbolic Hieronymous machine, he knew that people would accept.

His first subject was his young daughter who'd gotten results with the non-symbolic machine. She got a response with the symbolic machine and reported a "tacky feeling" at two points on the tuning dial. She was able to retune to the same dial readings, plus or minus two percent, on successive tries, even when her view of the dial was blocked and the vernier returned to the zero point before each trial run. After approximately a hundred additional subjects had tried it, Campbell confirmed that the percentage of subjects who got a reading was the same as with the non-symbolic machine - approximately 80%. Additional data: Children under the age of fifteen got consistently repeatable results while professional re-

## The Symbolic Hieronymous Machine

search scientists almost invariably got a clean, 100% no-response record. Convinced mystics got wild responses all over the dial.

Once a subject had gotten a response, Campbell would open the machine and show them what was inside. The most common reaction was, "Why, there's nothing inside!" But nearly 90% of the subjects continued to get responses even when they knew that the inside of the box contained only symbolic components and that the pilot light and "on-off" switch had absolutely no function whatsoever.

Campbell published the full instructions on how to build a symbolic Hieronymous machine along with his results and hypotheses in the February 1957 issue of *Astounding Science Fiction*.

What was truly astounding was the resounding silence that followed and has been maintained ever since. No research laboratories have followed up on this discovery. Perhaps some amateur researchers have carried on, but their results have not seen general publication.

### Author's Experience:

When I read the first Hieronymous Machine article in the June 1956 issue of *Astounding Science Fiction* magazine and built a non-symbolic Hieronymous machine, the results I got were interesting because the machine shouldn't have worked. Okay, I thought, the world is full of weird machines that we really don't

## Mind Machines You Can Build

understand yet, and I was intimately familiar with a lot of them that went under the general title of rockets. But when I read the February 1957 issue with Campbell's article on the symbolic Hieronymous machine, that was too much for me. Remember, I was educated as a physicist and trained in the field as an engineer. The article was obviously a hoax. I immediately set out to prove that it was a hoax by building a symbolic Hieronymous machine myself. I carefully followed the instructions given in Campbell's article.

It didn't work on the first try. I was about to write it off when I decided that there was something wrong with the circuit. There was no provision for a filament heater power supply for the vacuum tube symbol. So I added a symbolic filament inside the symbolic tube and "wired" it symbolically to a symbolic filament battery.

I was then hugely surprised when my symbolic Hieronymous machine worked!

My wife Barbara could get no response from it. But about 80% of my scientific and engineering colleagues did at White Sands Proving Ground and at the New Mexico College of Agriculture and Mechanic Arts.

I kept the machine and still have it. I take it out from time to time to try it on a new and unsuspecting subject. I've encountered two fascinating and inexplicable problems: (a) every couple of years, I must re-ink the battery symbols because the symbolic batteries appear to go "dead," and (b) I have to re-ink the vacuum tube symbol every ten years to put a "new and fresh" tube

## The Symbolic Hieronymous Machine

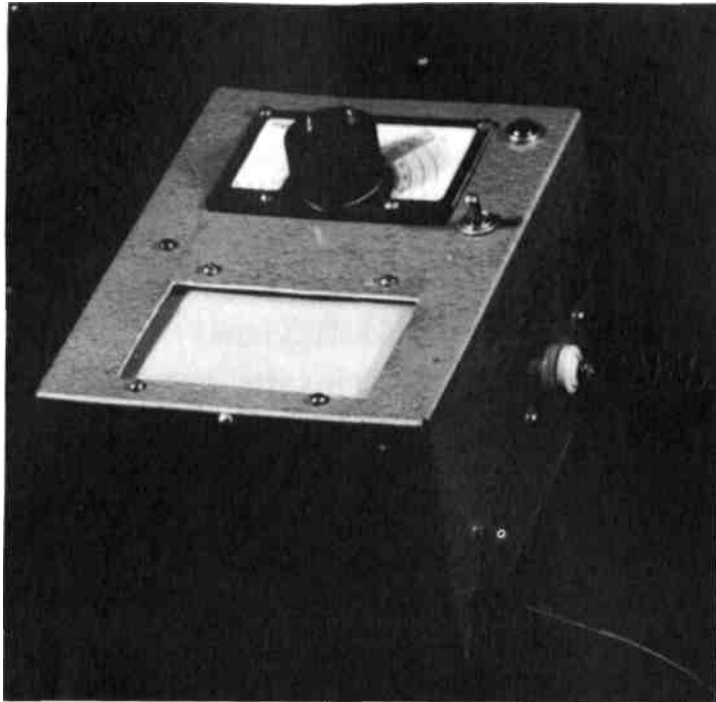

*Figure 8-1:* The author's symbolic Hieronymous machine built in 1956. It still works.  
But why does it work in the first place?

in the system. My solid-state versions haven't been in operation long enough to have encountered any failures of the "circuit chips" which, if my computer is any typical example, will exhibit outstanding reliability and long life exemplary of solid-state electronic components in the real world.

## Mind Machines You Can Build

### Instructions for Fabrication:

The symbolic Hieronymous machine is easier to construct than one of the full-blown hardware types. However, hardware is required:

1. An aluminum or plastic electronics component box.
2. A National Velvet Vernier Dial of the sort used in the standard Hieronymous machine.
3. A 4-inch by 5-inch piece of polystyrene or lucite ("Plexiglas") plastic sheet for the tactile detector plate.
4. A pickup coil - this can be wound as several turns of #18 AWG solid wire to make a simple air-core coil.
5. A small triangular-shaped piece of clear plastic to serve as a symbolic prism.
6. Various and sundry mounting and assembly hardware - nuts and bolts, standoffs, insulators, etc.

If you wish to include the pilot light and "on-off" switch, the following additional materials will be needed: a single-pole single-throw toggle switch, a 12-volt power transformer, a 12-volt panel-mounted pilot light and bulb, and an AC line cord and plug, plus mounting hardware.

The symbolic circuitry can be inked onto white cardboard or Crescent No. 201 Illustration Board (or equivalent). The circuit board and the tactile detector's

## The Symbolic Hieronymous Machine

coil can be cut out using a sharp modeling knife. Ordinary sewing thread may be used to connect the circuit board to the tactile detector coil board.

The precise size and shape of the symbolic components are not important. The material used in making the symbolic parts is not important. Workable models have been built from cardboard, plastic, vinyl tiles, sheet metal, and a host of other materials. Tiny pocket-sized machines have been built. The actual electronic circuits used don't seem to be important; a multi-staged transis-

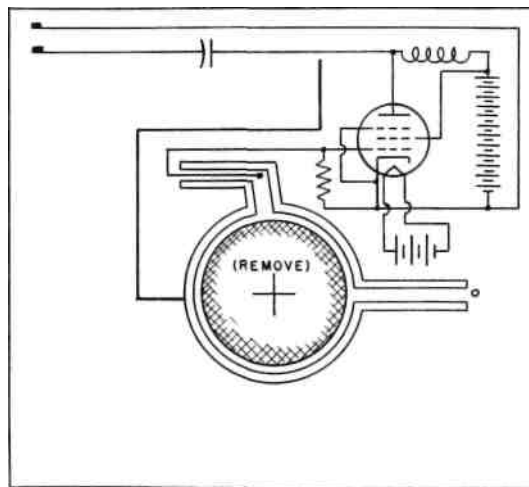

*Figure 8-2:*

Symbolic Hieronymous machine's vacuum tube amplifier circuit board. Drawing is full-sized for author's machine, but size isn't important.

Following the drawing accurately from a symbolic point of view seems to be critical.



## Mind Machines You Can Build

tor amplifier seems to work as well as a single-transistor unit. The precise type of symbolic op-amp circuit is apparently irrelevant. The only important factor is the *relationship* between the components plus the fact that operable circuits must be used - if actual physical electronic circuits were built using actual hardware and the circuit diagrams used in the symbolic machine, the physical circuits would indeed work as amplifiers.

I have seen an operable symbolic Hieronymous machine inked on the back of a 2-inch square of bathroom tile with the slick fired-enamel surface of the tile serving as the tactile detector.

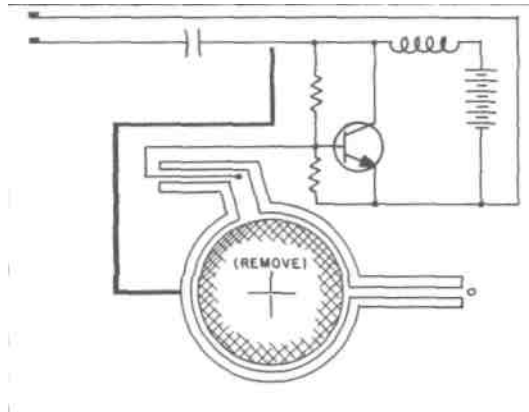

*Figure 8-3: Symbolic Hieronymous machine's transistorized amplifier circuit board for the "modern" solid-state version.*

## The Symbolic Hieronymous Machine

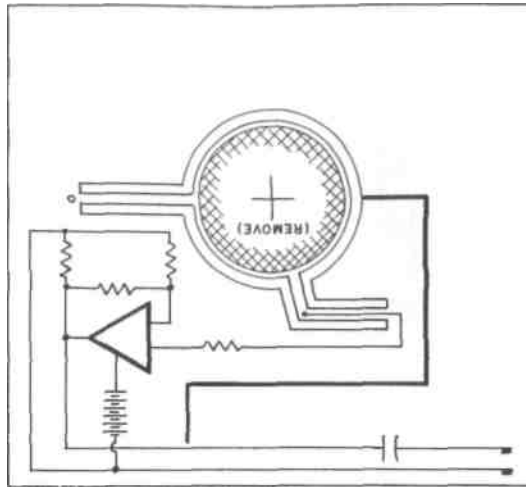
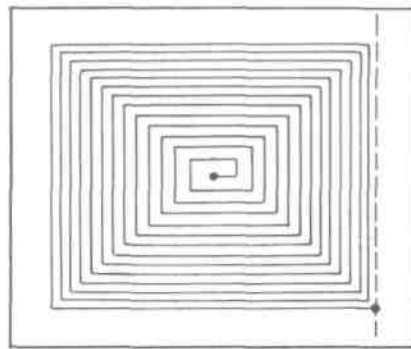

*Figure 8-4:* Symbolic Hieronymous machine's integrated circuit amplifier board for the latest state-of-the-art version.

So it doesn't seem to matter *what* you use to make it, *how big* you make it, or *how* you put it together just as long as the relationship between the symbolic parts remains the same.

*Figure 8-6:* Inside the author's symbolic Hieronymous machine showing placement of the prism and amplifier board. Transformer provides 12-volt power for functionless "pilot light" because the device is "battery powered."

## Mind Machines You Can Build



SPIRAL DETECTOR COIL  
SYMBOLIC HIERONYMOUS MACHINE

*Figure 8-5:* Detector coil layout drawing of the author's symbolic Hieronymous machine. Neither the number of turns nor the direction seem to be critical. Dashed line is "ground" symbol.

### Operating Instructions:

The operating instructions for the symbolic Hieronymous machine are the same as those for the physical component Hieronymous machine ("the original Hieronymous machine").

### Experiments:

The symbolic Hieronymous machine can be used for a wide variety of experiments.

## The Symbolic Hieronymous Machine

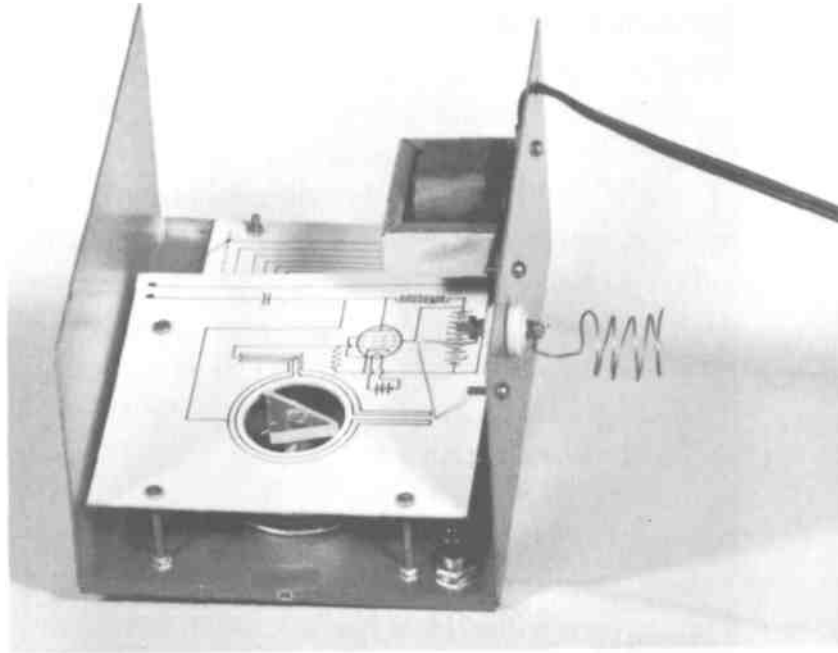

*Figure 8-6:* Inside the author's symbolic Hieronymous machine showing placement of the prism and amplifier board. Transformer provides 12-volt power for functionless "pilot light" because the device is "battery powered."

Some of these experiments can be done with the internal symbolic systems of the machine itself since this form of Hieronymous machine can be quickly and easily modified.

For example, various sorts of symbolic transistorized amplifier circuits should be tried ~ common base, common emitter, common collector, PNP, NPN, direct-

## Mind Machines You Can Build

coupled, wide-band, and other sorts of transistor amplifier circuits can be inked onto plug-in boards to permit quick change.

Various sorts of operational amplifiers and other integrated circuit diagrams can be tested.

When it comes to testing the machine on human subjects, you may wish to gather data on how many people get responses when a dummy "on-off switch and pilot light are used versus how many get a response when a "self-contained battery powered" version is used.

A very critical experiment needs to be done and verified by a large number of experimenters. Basically, it amounts to this: To what level of simplicity in terms of symbols can the Hieronymous machine be reduced before it doesn't work any more? Can box symbols be used to indicate circuits (the "black box" approach). I have done this myself, but I don't wish to affect the results of experiments by indicating the level to which I was able to reduce a Hieronymous machine before it stopped working *for me*. Remember: My original symbolic Hieronymous machine would not work for me until I had satisfied, in my own electronics-trained mind, that there was a proper battery symbol for the symbolic vacuum tube filament. I "knew" that a vacuum tube wouldn't work without a heated filament. That obviously affected my ability to get a response. But, on the other hand, I had built the machine. The absence of the filament battery and filament symbol should not have had any effect whatsoever on anyone operating the machine who did

## The Symbolic Hieronymous Machine

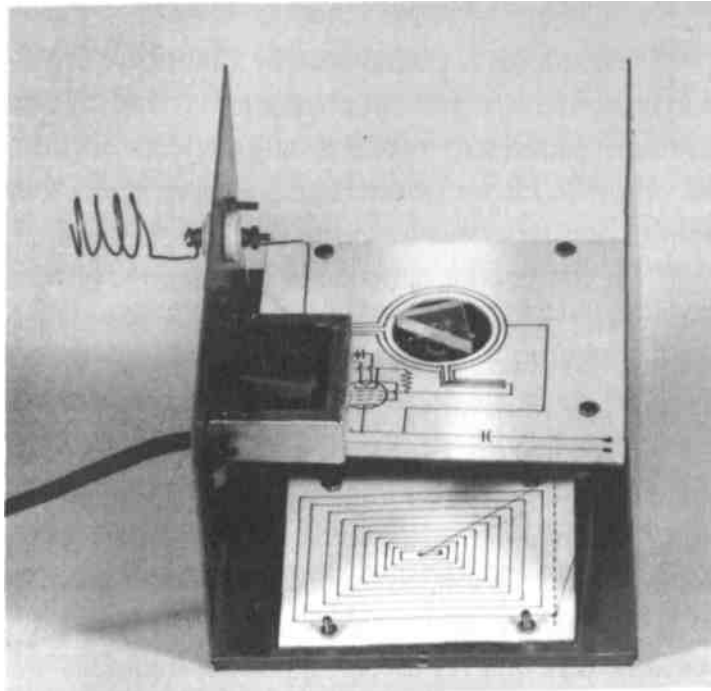

*Figure 8-7:* The other side of the interior of the author's symbolic Hieronymous machine showing placement of the spiral coil underneath the plastic detector plate and the connection between the amplifier and the coil boards using symbolic wires made from black thread.

not know what was inside the box! Campbell's original symbolic Hieronymous machine without a vacuum tube filament and battery worked fine for him and for the people that were his subjects.

## Mind Machines You Can Build

### What If It Doesn't Work?

As originally pointed out by Campbell, professional research scientists in physics and chemistry had an almost perfect zero score in getting any response from the symbolic Hieronymous machine, even when they didn't know what was inside it.

If you build a symbolic Hieronymous machine and cannot get it to work for you, you may have fallen victim to this unknown and un-named syndrome. Maybe it just won't work for you, period.

The first test is, of course, to try it on someone else, preferably a child or a person who isn't a professional researcher. In other words, try it on someone who doesn't already "know" in the back of his/her mind that such a device, no matter what's inside the box, can't possibly work and is probably a hoax or a joke.

Be exceedingly careful in running experiments with voluntary subjects lest you provide them with clues or hints as to what you think the response *should* be, or what results you might like them to get. People will sometimes (more often than not) work very hard to produce the sort of results someone else wants or that they've determined that someone else wants.

If you don't get responses from anyone, or if you want to check to make sure you've built the device properly in the first place, go back and make sure that the relationships between the symbolic parts are secure and as they should be. Check to make sure that your pen

## The Symbolic Hieronymous Machine

hasn't skipped and made an incomplete line while drawing the circuit diagrams. Check the "polarity" of the symbolic batteries and solid-state devices; you may have inadvertently switched battery polarity so that a PNP or NPN transistor symbol *is* wired in backwards and therefore couldn't work if the symbolic circuit were used as a map to construct the "real" physical circuit. Check to make sure that the threads used as symbolic wires are secure and attached; make sure they aren't touching one another and thereby symbolically "shorting out" each other. Change the orientation of the symbolic plastic prism by ninety degrees, test, and if no response is achieved, rotate it another ninety degrees.

In my device, the symbolic battery went "dead" after several years as "real" batteries are wont to do. I got my device working again by re-inking the battery symbol, thereby "recharging" or "replacing" the "dead" symbolic battery.

As a last resort, give the machine to an acquaintance and ask them to run experiments on other people without your foreknowledge of who, what, and where. The results should be interesting. To what extent were you affecting the performance of the machine, if you had any effect at all. And if so, why?

There is no reason why the symbolic Hieronymous machine shouldn't work for at least *some* subjects, even if it won't work for you. Data on who can and can't get a response should be kept. It should be correlated with personality and mood data of the subject.



## Mind Machines You Can Build

We're plowing very fresh and very unusual ground here. With the symbolic Hieronymous machine, we really don't yet know what the important parameters are or what measurements are important. Therefore, take as much data as seems to be relevant.

We need some sort of organization or society, perhaps computer networked, that can collect the experimental results from amateur investigators and develop a nationwide data base for experiments with thne symbolic Hieronymous machine...and the other amazing mind machines discussed in this book. But *you* organize it, not me. If I organize it, it will be tainted from the beginning because it may be claimed that I put it together in order to sell this book. You do it; I'll be there to help.

### Hypotheses:

Dr. T. Galen Hieronymous, the inventor of the original Hieronymous machine, has developed a hypothesis relating to the rationale for his device that invokes the concept of "eloptic radiation" as discussed in the previous chapter dealing with the Hieronymous machine.

The symbolic Hieronymous machine pretty well demolishes the "eloptic radiation" hypothesis. No known form of "radiation" and no aspect *of* the Universe that we currently define as "radiation" could possibly be in-

## The Symbolic Hieronymous Machine

voked to explain why symbolic marks and *surrogates* can cause an apparent physical change in a plastic plate that would be sensed by a human being.

As remarked previously, radiation is a sharply defined class of entity having definite characteristics and relationships with energy, which in turn can be converted back and forth as many forms of energy ~ heat, light, etc.

Waves and radiations and particles cannot be invoked in any hypothesis relating to the symbolic Hieronymous machine.

Occam's Razor would quickly trim any hypothesis based on extrasensory perception (ESP), "mental radiations," "thought waves," or even suggestibility. *If* the operation of the Hieronymous machine can indeed be explained by any of these hypothetical causes, it is therefore the first and most powerful of the instruments to be used in parapsychological research. If it does operate because of the subconscious mind, telepathy, or even suggestibility, it is a powerful tool for psychological research and should therefore immediately be seized upon and put to work there. But it hasn't. And it's been around long enough for the original patent protection to have expired.

Details of both types of devices have been published in a magazine with more than 100,000 circulation on a worldwide basis. Dr. Hieronymous himself was not the typical inventor who wished to maintain control of all rights to his invention; in connection with the original

## Mind Machines You Can Build

magazine article on the Hieronymous machine, he publicly gave permission for investigators to build and investigate it. Therefore, no one can give as an excuse that the machine was (a) obscure because publication, if any, was in private journals that weren't widely circulated, or (b) too tightly controlled by the inventor, a factor that prohibited serious investigators from looking into it for fear of legal action on the part of the inventor. None of these two factors are true.

Nor can the operation of either Hieronymous machines be easily fobbed off or explained away as a hoax. It has operated successfully for far too many people. Hieronymous machines of both types have been built and operated by people who have had nothing more to follow and learn from than the printed words and illustrations in a magazine. Hieronymous machines have been built and operated by high school students in science fairs as well as high-technology engineers (and a few physical scientists).

It is patently apparent that we are here dealing with a totally new and formerly unsuspected aspect of the Universe.

I do not know what it is, and I cannot describe it to you.

But I can make some WAGs (Wildly Assumed Guesses) concerning it because one must have somewhere to start. I will probably be proven wrong. But in

## The Symbolic Hieronymous Machine

displacing my WAG, someone will have to come up with a hypothesis, and it should be a testable hypothesis. My guess is based upon data.

With both Hieronymous machines, I submit that we are dealing with devices that are definitely not physical science devices.

The physical power of pure symbols can be physically demonstrated and *was* in the previous chapter.

The Hieronymous machine is capable of being built and operated on a purely symbolic basis. Therefore, it is not a physical sciences device.

We are working on the level of pure symbolism. A symbol is what it is because it is defined as being that symbol which is further defined by us as having certain powers. This fact, demonstrable by the Hieronymous machine, makes the behavior of symbolic systems such as this device completely capable of apparently violating one of the basic laws of the physical sciences which states that any object in the Universe must have the same characteristics for any two observers.

That this principle doesn't apply to everything in the Universe should come as no great surprise to those researchers involved in the life sciences where it is widely accepted that no two given organisms, even those with the same genetic material, need have the same characteristics for any two investigators. But a very large statistical Universe of these organisms can and do operate in predictable manners as *a population*.

## Mind Machines You Can Build

### Conclusions:

I submit that Dr. T. Galen Hieronymous has indeed discovered and put to use a totally new-to-us principle of the real Universe that can and will, in time, be thoroughly tested, defined, and proven as a theory and, eventually, as a new Universal law. Furthermore, I submit that practically none of the initial work will be carried out by professional scientists as a professional inquiry because I know very few professional scientists - even those with very open minds ~ who could easily afford to undertake such investigations for fear of peer pressures. It will be done by amateurs such as you and I because there are no professionals in this new "proto-science" yet.

Further conclusion: I don't know what this new Universal thing is, and I don't think anyone else knows either. But it's certainly going to be challenging, fun, and exciting to find out what's involved!

## CHAPTER NINE

### THE WISHING MACHINE

#### Basic Description:

The Wishing machine is a reasonably standard three-transistor common-emitter RC-coupled audio frequency amplifier with two simple flat copper plates on the input - one at ground potential and the other connected to the high-impedance input of the amplifier ~ and an output consisting of a simple vertical rod antenna. It is powered by a 6-volt battery.

## Mind Machines You Can Build

The device appears to be effective in accelerating growth or decay of reasonably simple life forms such as viruses, bacteria, fungi, plants, insects, and lower animals.

When a symbolic sample - a photograph of a plant, field, tree, or person, for example - is placed between the two copper input plates and the amplifier is turned on, the experimenter then consciously thinks of some change he desires to occur or some *wish* concerning the object symbolized in the sample placed between the plates.

The device has apparently been known to (a) achieve a 90%+ kill ratio of Japanese beetles in 90 test plots in tests conducted in the 1950s by the Pennsylvania State Department of Agriculture; (b) achieve a 70% kill ratio against corn borers in other tests conducted by the same agency; (c) destroyed tent caterpillars in a tree 1200 miles from the site of the device; (d) all but eliminated acne from the skin of an adolescent girl; and (e) eliminated a large number of severe warts on an infant girl. There may have been other tests conducted and other results achieved, but the author has some documentation on these.

The device apparently does not work in a destructive mode against other human beings. In other words, it is not a murder machine, which is why it can be considered for publication in this book. However, it appears to be a member of a class of "Wishing ma-

## The Wishing Machine

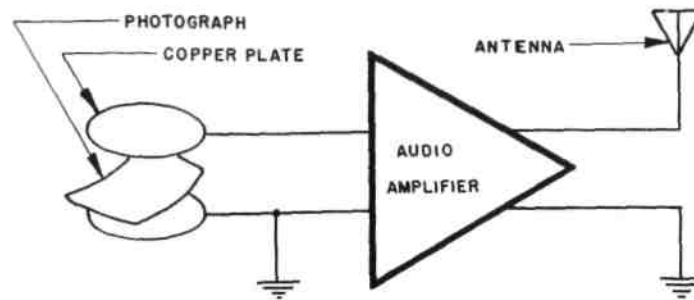

*Figure 9-1:* Block diagram of the wishing machine.

chines" in general, some of which can and apparently have been used as such. This doesn't seem to be voodoo magic, but it appears indeed to be magic under the definition of that term as it has been used in this book.

### Historical Background:

Work on this particular machine apparently was initiated in about 1946 by Colonel Henry Gross (Yale, 1906), a banker and investor who was at that time head of the selective service system for the state of Pennsylvania. He was assisted by two other gentlemen named Upton and Armstrong, both Princeton Class of 1905. Additional data on these latter two men has not been located. Work began when the wives of Upton and Armstrong both died of cancer within two months of



## Mind Machines You Can Build

one another in 1946, whereupon the three men decided that if nothing known to science at that time could have saved the two women, they should start looking beyond science. All three pursued their goal as a hobby with no desire to make money; they'd already done that. They apparently were pure amateurs in this regard. The Pennsylvania tests were apparently conducted in the early 1950's.

### Author's Experience:

I heard about this Wishing machine in a private communication from John W. Campbell, Jr. dated June 22, 1956. Apparently, Campbell's publication of the article about the Hieronymous machine brought responses from a large number of people working on or having had experience with other such machines. Since this was such a simple device (like the symbolic Hieronymous machine), I built one.

My eldest child, Constance, was at that time less than three years old and suffering badly from warts. Warts are, of course, caused by any one of a number of different viruses. She was especially susceptible because she had warts everywhere, and we had grown increasingly concerned about their locations and extent of growth. Medical treatments had included such severe measures as direct treatment of the warts with arsenic acid, a procedure that seemed to me rife with hazard in an infant.

## The Wishing Machine

I placed a photograph of my daughter between the input plates of my Wishing machine, turned on the battery power, and consciously thought about those warts going away, about killing the virus that was causing the warts, and about my daughter without them. I kept the Wishing amplifier constantly operating on battery power, since from time to time during the subsequent days I kept thinking about her and those warts.

The result was frightening. Within three days, my daughter's warts had decreased markedly, including those that were beginning to grow inside her nostrils. Within four weeks, she was free of warts and has not had anything like them since.

I disassembled my Wishing amplifier because I was afraid of what I might henceforth do with it. At that time in my life, it seemed that this phenomenon involved too much personal power of a sort that I didn't understand and felt that it might not be controllable. I wasn't certain whether or not I could handle it. All of us are secretly aware of the impulsive beast that hides deep within us. Indeed, most of our rearing and education is aimed toward demanding that we restrain that beast in a mental cage in the deep recesses of our mind...and please throw away the key.

The machine was also sheer, outright magic whose consequences were far beyond those of machines such as the dowsing rods and Hieronymous machine which were, by comparison, almost parlor games.

## Mind Machines You Can Build

In the years since, I have learned that such devices (and there are many of them) can be safely used by most people because we have built-in "circuit breakers" or "emotional fuses" that prevent most of us from using such machines for destructive purposes. Furthermore, we've been taught to use and depend upon them with dire consequences for those who didn't.

Beyond that, however, appears to be an accumulation of data that indicates such machines are useful only against fairly simple living organisms which operate totally on a pre-programmed or instinctual basis. Such organisms behave as systems without feedback with only linear programming; disrupt the programming and the system stops. It does not work on human beings who can and do over-ride instincts with higher thought processes.

I hesitated to include this device in this book for two reasons: (a) it is probably the most atrocious and impossible of all the amazing mind machines I've ever encountered and one of a class of devices for which it is extremely difficult, if not impossible, to either dismiss out of hand, explain away, or even generate a reasonable hypothesis of how and why it works at all, which it does; and (b) because of the total lack of any concept of why and how it works, there is always a serious question about whether or not the data on the limitations of its effectiveness are complete and totally valid. However, simply

## The Wishing Machine

because of these two factors, it is necessary to get the information out to amateur investigators so that some additional experimentation may clarify the situation.

### Instructions for Fabrication:

As discussed above, this device is a straightforward transistorized audio amplifier. It *may* be operable on the symbolic level in concert with other devices such as the Hieronymous machine. Instructions given here are for the physical parts unit, however.

A suitable transistorized amplifier circuit is shown in Figure 9-1. The values of the components are called out. All of the parts can be purchased at stores such as Tandy Radio Shack. The amplifier can be built on an ordinary phenolic board and enclosed, along with its battery and the antenna mount, in an electronic component box. The two metal input plates can be easily obtained at most craft and hobby shops. Although copper was used in the original device built by the author, any electrically conductive plate can be used. Aluminum and brass sheets are available in most hobby shops. The antenna is a simple collapsible rod that can be taken from a scrapped portable transistor radio or CB transceiver. Or the antenna can be nothing more than a piece of stiff wire.

## Mind Machines You Can Build

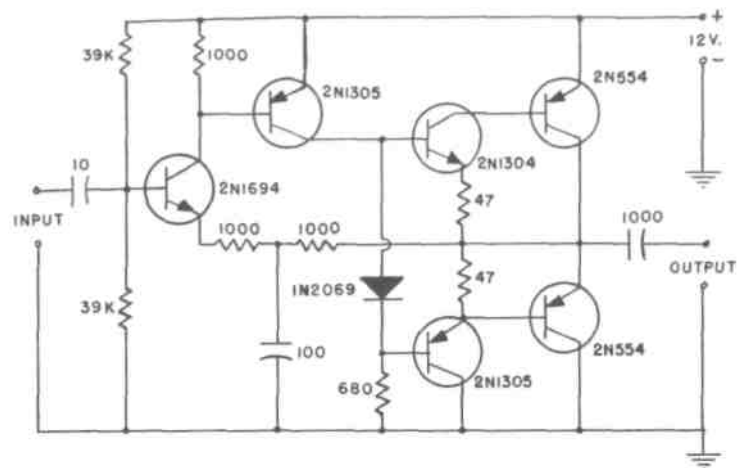

*Figure 9-2: Circuit schematic for a transistorized audio amplifier that can be used in the wishing machine. Actually, any audio amplifier can be used. This one is presented as a suggestion only.*  
Question: Will the wishing machine work with only the drawing of the amplifier as the symbolic Hieronymous machine does?

### Operating Instructions:

The operating instructions are as deceptively simple as the instructions for making this machine.

To be effective, the device must use some input sample that is directly connected symbolically to the object the experimenter wishes to be changed. For example, a photograph of the insect-infested tree or field

## The Wishing Machine

can be used. A leaf from the plant or a piece of paper containing a drop of dried blood from the individual can be used. The only factor affecting the operation of the machine appears to be the direct causative connection between the machine and the subject - i.e., light rays from the tree fell upon the photographic negative, causing a change in the chemical salts of the negative material. Place the photograph or sample between the two input plates. Turn on the amplifier. Make your wish. Leave the amplifier turned on. From time to time, think about your wish or desired action. As is typical of machines of this class, distance has no effect upon its operation - i.e., the distance between the machine and the actual subject or the distance between the machine and the operator apparently have no effect upon its operation.

### Experiments:

If there was ever a mind machine that was super-amenable to experimentation, this is it.

I have not been able to obtain the results from the tests conducted by the Pennsylvania Department of Agriculture in the early 1950's in which it is reported that Japanese beetles were eliminated from 90 test plots in the western part of the state when the machine and operator were in the eastern part of the state. The results may languish in some archives there or, most probably, were

## Mind Machines You Can Build

tossed out years ago because any scientist in his right mind knows that such a machine can't work and that the results have somehow been rigged.

A number of definitive experiments suggest themselves and can be carried out simply and easily by amateur scientists at the high school level. The easiest of these would use numbered Petri dishes containing bread mold from a common source. The experimenter should concentrate on reducing the growth rate in a Petri dish with a given identification number on it. A photograph of that Petri dish should be placed between the input plates. The machine may be located anywhere during this experiment, but the Petri dishes should all be kept together in the same environment. The growth of the bread mold in the various Petri dishes can be visually determined, and a record should be kept.

Another experiment with bread mold growth can be conducted when the operator is not the experimenter and does not know the number of the Petri dish whose photograph is between the plates, and who simply *wishes* that the object whose photograph is at the input be changed.

Experimental organisms can also include bacteria, insects, and plants.

Does this device have any effect upon the growth rate of bean sprouts as in the pyramid experiments?

## The Wishing Machine

If positive results are obtained, the experiment should be repeated with the machine located in a remote site to test the apparent fact that distance has no bearing on the experimental results.

The Pennsylvania tests can and should be repeated by many investigators. Choose a tree or a field with insect or fungal infestation. Photograph it. Put the photograph between the plates. Have an independent observer keep a record of what happens to the test plant or field as well as to a control plant or field nearby with similar infestation whose location and condition is totally unknown to the experimenter.

These experiments and others are simple, inexpensive, easy to conduct, easy to control, and easy to evaluate. They can and should be made by a large number of investigators. It is quite unlikely that they will be carried out by professional researchers, but, if any are, it is also equally likely that the results will turn out negative. That is why it is necessary and desirable to have these experiments conducted by amateurs who have nothing at stake except curiosity or a flaming desire to prove that the author is stark, raving mad. (This latter motivation was the one that got me started in this whole tiling in the first place because I *knew* it *had* to be a fraudulent hoax and it was so easy and cheap to run the experiment to prove my point.)



## Mind Machines You Can Build

### What If It Doesn't Work?

If your Wishing machine doesn't work, there may be one of several reasons:

1. You didn't build it right or you're not doing something right when trying to use it. As the old saying goes, "If at first you don't succeed, try reading the instructions."

2. There's a bad transistor, component, solder joint, etc. in the machine that disturbs something that affects the Hieronymous machine and probably affects the Wishing machine: the relationship within the system has been disrupted.

3. You're too impatient. Give it a couple of weeks. Rome wasn't burned in a day....

4. Your personal circuit breakers are set very low and you just can't operate such a device no matter how hard you try; you're blocking yourself somehow. Let someone else try it.

5. Subconsciously, you believe it's magic and it can't work, or that you'll be discovered and burned as a witch. Don't dismiss the powerful effect of our cultural programming.

Since nobody really knows what's going on here in the first place, maybe none of these reasons are basically valid. Maybe you just can't get one to work, period. On the other hand, others can and have.

## The Wishing Machine

### Hypotheses:

It's possible to come up with any number of hypotheses concerning why the Wishing machine and its general class of devices work. But it's totally impossible at this point to effectively test any of the hypotheses because we can't come up with *any* hypothesis based on what we already know in science.

In the case of the detector rods, it was possible to hypothesize some means of information transfer from the object to the searcher that would cause a change that would cause the rods to move. Not so here.

Pendulums and energy wheels may be explained by hypotheses that include the well-known principles *of* electrodynamics and the ability of people to willingly change the electrical characteristics of their bodies. Not so here.

The actions of pyramids may be explicable on the basis of extremely weak electromagnetic activity, the resonant characteristics of the pyramid shape, and the low energy levels required to affect molecular bonds in crystalline materials. But none of that appears to have any bearing on Wishing machines.

The concept of "eloptic radiation" was one hypothesis relating to the operation *of* the Hieronymous machine, although the success *of* the purely symbolic Hieronymous machine would seem to render any "ra-

## Mind Machines You Can Build

diation" hypothesis invalid. In the first place, the basic concept of "radiation" includes the concept of "distance," and "distance" apparently has little if any effect upon the operation or effectiveness of Wishing machines. Therefore, the concept of radiation cannot be invoked here. As with the symbolic Hieronymous machine, we are beginning to get into a totally unknown realm.

Unlike the previous devices, with the symbolic machines such as the Wishing machine, we appear to be dealing with phenomena that are truly out at the very fringe of our Universe of knowledge. We may be unable to formulate any hypothesis whatsoever for decades or perhaps a century.

But, unless someone begins looking, we may never find out at all and may forever be denying ourselves some important bit of information about this Universe that could be of enormous benefit to people.

No rational hypothesis can be formulated that would even begin to take into account most of the experimental data and reported phenomena of the Wishing machine.

Why is distance apparently not a factor when with every other aspect of the Universe distance is indeed one of the primary dimensions?

Why does the Wishing machine appear to operate only on the level of organic life and then only on those organisms with no volition, no ability to over-ride their instinctual, genetic programming?

## The Wishing Machine

The easiest way out is the Ostrich Syndrome: It's a hoax. Then please explain what happened to those Japanese beetles in those Pennsylvania fields... to that teenager's acne... to my infant daughter's warts. Coincidence, you say? If those were mere coincidences, they were indeed fortuitous. And if the machine somehow affected these coincidences or the probabilities thereof, it's far more environmentally benign than insecticides and far more effective than Clearasil and arsenic acid! And if it is affecting the probabilities in these cases, how and why is it acting this way and would it do something similar in Las Vegas and Atlantic City?

Or one might excuse it away by claiming that it simply operates to reinforce suggestibility. If it's that good at it, this data should be extremely useful in psychology and psychiatry because it's far superior to hypnosis and conscious-altering drugs. And Madison Avenue would have snapped it up long ago....

Saying it works because the operator believes it works doesn't explain it and is no hypothesis, only an admission that it does work and that this may be a reason. Why does it work only if the operator believes it does? According to what we think we know about the rest of the Universe, this shouldn't be. It strikes at the very roots of scientific inquiry.

Maybe that's basically all it's about anyway.

## Mind Machines You Can Build

### Conclusions:

These are conclusions reluctantly arrived at on the basis of data in hand to date:

1. The Wishing machine works.
2. It works only against living organisms whose nervous systems are not complex enough to include volitional action as an operational mode.
3. Distance appears to be no factor in its effectiveness.
4. There is no basis in current scientific knowledge to support any hypothesis concerning why it works.
5. With continued experimentation, we can probably learn why it works.
6. We must be willing to continue experimenting.

## CHAPTER TEN

### POSTSCRIPT

I've presented each device herein as an example of a particular class or type of mind machines machine. You may know of others.

I also tried to constrain the machines I discussed not only to those which I had built and tested myself, but also those that could be built and operated by anyone who could read and follow instructions. Furthermore, none of them require personalized instruction or train-

## Mind Machines You Can Build

ing. This approach has always been the hallmark of scientific inquiry as opposed to mysticism where the operator must be personally trained by an adept.

Therefore, I didn't discuss such weird and wonderful machines as the Drown machine and the De La Warr machine. According to reports, both apparently work. However, I have not seen one, built one, or operated one. In addition, both machines require training by experts in their use. Not everyone can operate them by reading an instruction manual. I didn't exclude them on the basis that the American Medical Association has declared them to be hoaxes. I had no basis for deciding whether they were real or shams.

However, the fact that something has been pooh-poohed by experts was, is, and never will be any reason for me to pooh-pooh it, too. An expert is another human being just like thee and me. Said expert merely has acquired a mass of expertise that thereafter he must jealously guard because it may be the only prop supporting the person.

Here's the way to treat an "expert": Listen to them to get the benefit of their expertise. They'll tell you what can be done; and it undoubtedly can. When they tell you it can't be done, try to do it anyway. When they begin to pontificate on subjects outside their field of expertise, they pack no more clout than you or me. I don't claim

## Postscript

to be an expert on anything. I'm still learning. I'm an amateur and proud of it. If there were more amateur scientists, perhaps science would advance more rapidly.

Some readers may feel I've included some strange machines herein that they consider mystical and whose results they consider extremely subjective. Be advised that I deliberately eliminated from consideration a very large number of devices that are not understood and produce questionable physical responses.

By now, you've realized that these eight strange machines share several characteristics:

1. In light of everything we've been taught about the Universe, these machines shouldn't work. But they do work demonstrably and repeatedly for a significant number of people. These devices are maddening because they work well and reliably for some people and not for others. On some days, they won't work at all even for adepts.

2. They can be built and operated successfully using only written instructions without any personal contact with the inventor or advocate.

3. They produce repeatable results with a large enough percentage of subjects that the factor of random chance cannot possibly be expected to affect the results or play a part.



## Mind Machines You Can Build

4. No accepted theory explains why each of them works. In fact, there are no hypotheses concerning why or how some of them work at all. This doesn't keep them from working.

5. They are ignored by the professional community of scientific investigators. Most scientists claim these devices are hoaxes but have never spent any time investigating them with the same level of rigor they apply to their own field of interest.

6. Because the causes for the operation of these machines are unknown, they are and should become legitimate targets of investigation by those who are interested in expanding the horizons of human knowledge and our understanding of the Universe.

7. In the cases where these machines have utility, what they do can be done at least as well by other devices whose operation we more or less understand. For example, many geological tools are available to help us locate underground water. Yet dowsing rods have been used for centuries and are indeed depended upon throughout the world today. A razor blade may be re-sharpened by a whetstone and leather strop. A mass spectrograph will not only identify the elements present in a metallurgical sample but provide quantitative data as well. However, utility isn't at question here. The bothersome question is, "Why do the damned things work in the first place?"

## Postscript

My basic thesis in this book has been that we don't know why they do or don't do, what they do or don't do, but that they do indeed do it. Therefore, we should make a serious attempt to find out *why*.

And if that isn't the basic purpose of legitimate scientific inquiry, then what is?

Please note carefully that I do not advocate any particular religious doctrine or cult of worship in connection with any of these machines. Some religious cults and "mental expansion sciences" may have adopted one of them for their purposes. Some readers may identify one or more of the strange machines herein as being the favorite tools or toys of such groups. So what? This doesn't mean that it should not be investigated, particularly if it works. Divorced from cult context, the critical question remains: Does it work or doesn't it? And, if it does, why?

I'm not selling the modern technological equivalent of snake oil. I'm merely trying to get these strange machines out in the open where inquiring minds can learn of them. Faith has absolutely nothing whatsoever to do with the operation of any of the devices in this book. I do not maintain that you have to believe in *anything* except that these machines can be investigated by scientific protocols and explained in a fashion that is not inconsistent with the rest of the Universe.

## Mind Machines You Can Build

Since anyone can build and test them according to the instructions herein, no one has any excuse to claim at the outset that these devices are hoaxes or that they depend upon suggestibility or gullibility. If they work because of suggestibility, they should therefore have some utility in psychology because the suggestibility is transferred not by personal contact but remotely through written symbols on paper: this book. And if this is indeed the case and if suggestibility is the reason the devices work, we'd better find out why they work by such remote-control suggestibility!

I have nothing to gain by writing this book except a percentage of the book's sales price called a book royalty. Book royalties rarely make authors rich. If they did, there would be far more wealthy authors. If making a million dollars had been my aim, I would have approached the subject quite differently in a highly sensationalistic style and manner. As it was, I tried to present the information in as straightforward a manner as I could.

On the other hand, I do have something to lose by writing this book. In more than forty years of writing, I've built a reputation that has some semblance of truthfulness, sobriety, and careful research. I've never espoused far-out causes except ones that I knew perfectly well were within the capabilities of science and technology like going to the Moon and industrializing space. I do not wish to destroy that hard-earned and carefully preserved

## Postscript

reputation now. In fact, the possibility that I might do so as a result of this book has been of concern to me throughout its preparation.

This is why I reported only on strange machines that I have personal experience in building and/or operating. My formal academic science education continually reminds me that I should report publicly those phenomena that I have carefully observed and thereafter bare myself to peer review and criticism. The problem is that while there are many scientists in the world, there are few who have any experience in strange machines and are therefore qualified to express opinions about them. So I'm laying myself wide open to criticism from experts who aren't but who think they are.

Our limited knowledge of ourselves and our Universe has grown over the past five centuries. In the eighteenth century, electricity and magnetism were mystical phenomena. In the past, things we accept today were greeted with jeers and outright derision. In 1807, Thomas Jefferson who was then President of the American Philosophical Society (the equivalent of today's American Association for the Advancement of Science) reacted to a report of a discovery of a meteorite by two Connecticut astronomers with the statement, "I could more easily believe that two Yankee professors would lie than stones fall from heaven." In the nineteenth century, much of what is now twentieth-century science was

## Mind Machines You Can Build

laughed at. The reknowned physicist and former President of the British Royal Society, Lord Kelvin, stated in 1900, "X-rays are a hoax."

We can probably expect no less from our reknowned twentieth century savants when it comes to phenomena that may well represent twenty-first century science.

On the basis of a long study of the history of science and technology, however, I am convinced that somewhere among these strange machines lies the foundation of the science and technology of the twenty-first century.

Far too many people are still operating under the obsolete philosophy of materialism that was developed during the nineteenth century and dominated far too much in the twentieth. One of the beliefs of materialism is that we know everything there is to know about the Universe. But scientific inquiry itself proves this assertion wrong every day.

Science is not a static body of knowledge. It grows. Here is a direction in which it can grow without requiring millions of dollars of support in terms of grants. It can grow under the aegis of amateurs. In fact, it must. This will, however, infuriate some of the professional scientists who may fear that, in spite of their skepticism, there just might be something here after all.

## Postscript

RCA engineer Harry Swartzburg stated, "The validity of a science is its ability to predict." Well, maybe these proto-sciences we're talking about aren't that far along yet. But they're getting there. I can now write a book describing some strange, unexplained machines so you and thousands of others can build them and see for yourself. That's a start. In fact, it's the first step in any potentially new field of science.

Scientific fields of endeavor begin with such unexplained phenomena as those we've discussed in connection with strange machines. From the basic laws of motion (dynamics) to the most modern theories of nuclear structure and cosmology, each advance began with the actions of an individual whose curiosity was piqued by a strange and perhaps even accidental or fortuitous phenomenon. They also had the belief that a reason for the phenomenon existed and could be learned.

Therefore, the reason(s) why these strange devices and others work can and will be discovered. In the process of doing this, new and unsuspected fields of science and knowledge will be uncovered.

Maybe this will be done by a reader of this book.

However, if I've piqued your curiosity and caused you to investigate some of the amazing machines reported herein, then I've done what I set out to do.

But, please, a few words of warning to those who will enthusiastically undertake experiments with these machines and others that they may come upon:

## Mind Machines You Can Build

Don't write to ask me details of how to build or operate the strange machines of this book. I've told you everything I knew when I started working with them and therefore everything you need to know to get started. Go back and read the text carefully again. "If at first you don't succeed, try reading the instructions."

And don't demand things of me. I'm just an amateur like you. We all are. I don't get paid for investigating strange machines. Nor am I in the business of selling them and thereby keeping customers happy. These machines are simple and safe enough that you can and should try them your way and *do* a few experiments on your own.

Don't complain to me if something doesn't work because, after all, even with the most complex of these machines, you're out only a few dollars and a few hours' time. What did you expect? I told you at the start that maybe it wouldn't work but that there was a good probability it would because it worked for me. The only promise held forth by this book was that perhaps it would be found entertaining. At worst, it could be infuriating.

But I hope you've learned a little something about science, scientific investigation, and the conduct of scientific experiments along the way. And maybe something about how abysmally ignorant we are about the Universe.

## Postscript

Don't write me enthusiastically about a machine somebody else has invented that performs miracles unless you yourself have built it, tested it, and confirmed the results without personal contact with the inventor.

Don't write to me about the wonderful machine that you've invented, that you've tried on thousands of people, and that you've personally taught hundreds of people to operate. Sorry, but it doesn't count. Close, but no cigar! The world is full of miracle machines that won't and don't work at all out of the hands of the inventor. (And I've seen hundreds of these, too.)

But if you've invented a strange machine, written it up, published the description and the experimental results, had people build and operate it from that written description without personal contact with you, and gotten reports that it works, I'll gladly read your letter.

The same holds true if you've built a strange machine from someone else's written instructions and had it work.

*Totally independent verification* is a key element.

Don't complain to me that there's no place to publish your work. Look harder. Even the prestigious New York Academy of Sciences has published some pretty strange, off-beat, and off-the-wall papers. Not all scientific organizations are as stuffy and priest-like as you may have gathered from what I've written here. A lot of good and honest scientists are around. There are also



## Mind Machines You Can Build

many places to publish your work. Maybe that fact that it's continually rejected is no reflection upon the subject matter but on the way you've written it up.

I'm a skeptic or I wouldn't have gotten involved with strange machines more than a third of a century ago. And you'd better be a skeptic, too, lest the rude hand of reality rise up and smite thee right in the middle of thy cherished beliefs.

But don't just read about these and other strange machines and then dismiss them skeptically. Build them and try them. Test them. Then and only then do you have the right to an opinion on any given one of them, but not about the ones you haven't built and tested.

Don't worry about the experts. They'll tell you only what can't be done. It's up to you to go ahead and do it if it really is possible. You'll never know unless you try. Remember that the history of science and technology is littered with the solemn pontifical pronouncements of experts.

"The theory of germs is a ridiculous fiction," said Pierre Pochet, professor of physiology in Toulouse, France, when he learned of the germ theory of disease developed by Louis Pasteur, who was a crystallographer, not a doctor. Others even refused to look at his data.

"The abdomen, the chest, and the brain will be forever shut from the intrusion of the wise and humane surgeon," said Sir John Eric Erichsen in 1837; he was later to become Surgeon-Extraordinary to Queen Victoria.

## Postscript

The most famous "expert statement" of all came from Charles H. Cuell, Commissioner of the U.S. Office of Patents, who urged President William McKinley to abolish the Patent Office in 1899 with the assertion, "Everything that can be invented has been invented."

I wonder what the experts are going to say about the strange machines of this book? Frankly, I don't expect anything different than what they've said in the past.

No matter what they say, many phenomena remain unexplained. Innovation comes from individuals who see a consistency in these phenomena that have been missed or dismissed by others. This sort of innovation ought to be encouraged, even at the risk of seeming to encourage charlatans. The great leaps forward in our understanding of the Universe and ourselves have come from just such activities in the past. Once the leaps have been made, the cautious scientists must then carefully fill in the added decimal places.

You're hereby challenged to make the great *scientific breakthrough of the twenty-first century*. Maybe it starts with something from this book, and I will be mightily pleased if it does. But I don't disabuse myself; probably it won't.

But even if you don't make the great scientific breakthrough, you'll have some fun!

## Mind Machines You Can Build

## BIBLIOGRAPHY

Bird, Christopher, *The Divining Hand*, New Age Press, Black Mountain NC, 1979.

Campbell, John W., Jr., private correspondence, June 22, 1956. '

Campbell, John W., Jr., "Psionic Machine, Type One," *Astounding Science Fiction*, Volume LVII, Number 4, June 1956.

Campbell, John W., Jr., "Unprovable Speculation," *Astounding Science Fiction*, Volume LVIII, Number 6, February 1957.

Campbell, John W., Jr., "Addendum On The Symbolic Psionic Machine," *Astounding Science Fiction*, Volume LIX, Number 4, June 1957.

Cerf, Christopher, and Navasky, Victor, *The Experts Speak*, Pantheon Books, New York, 1984.

## MIND MACHINES YOU CAN BUILD

Flanagan, G. Patrick, *Pyramid Power*, De Vorss & Co., 1046 Princeton Drive, Marina del Rey CA 90291, 1973.

Flanagan, G. Patrick, *Pyramid Power II*, Innergy Publications, P.O. Box 18224, Tucson AZ 85731, 1981.

Stine, G. Harry, *The Hopeful Future*, Macmillan Publishing Company, New York, 1983.

—, *Edmund Scientific Catalog*, Edmund Scientific, 101 E. Gloucester Pike, Barrington NJ 08007, 1984.

—, *The Radio Amateur's Handbook*, American Radio Relay League, Newington CT 06111, 1984.

## ABOUT THE AUTHOR

G. Harry Stine graduated from Colorado College in Colorado Springs, Colorado (his home town) with a B.A. in physics in 1952. Before deciding on a degree in physics (because of counselling from Robert A. Heinlein who coached him in writing), he was within a semester of gaining his bachelor's degree in psychology at the University of Colorado. He spent the early 1950's at White Sands missile range in New Mexico working with high altitude rockets and rocket motor testing. He founded the international hobby/sport of model rocketry in 1957. During the 1960's he was the manager of an industrial research laboratory in New England where he worked on many "far out" projects such as neurophonics, Coanda

Effect, electrohydraulics, bioelectronics, and dynamic systems. In 1968, he was awarded a silver medal as one of 50 U.S. space pioneers by the Association of the U.S. Army.

He is the author of more than 50 books, numerous scientific and technical papers, and hundreds of magazine articles since 1951.

He is a Fellow of the Explorers Club and the British Interplanetary Society, and a member of the New York Academy of Sciences.

An instrument-rated private pilot who's been flying since 1943, he owns his own airplane, a Piper Cherokee, which he's flown across the United States and back many times. He lives in Phoenix, Arizona, "in the midst of high technology" with his wife, two Golden Retrievers and a cat.

He's listed in *Who's Who In America* as well as the current editions of *Who's Who In The West* and *Jane's Who's Who In Aerospace*.

### ***Experimental Mind Machine Supplies***

*ENERGY WHEEL*® by Gerald Loe As pictured on page 68, complete with instructions. Easier to turn because of less mass (?).

\$5.95 plus \$3.00 shipping

#### **HIERONYMOUS TILE**

2" X 2" Tile as described on page 152.

\$3.00 includes shipping

*SYMBOL EXPERIMENTERS PACK* Contains *Left-Hand Spiral, Right-Hand Spiral, Special Strengthening or Weakening test card* (not shown in book) all printed on 5.5" x 8.5" Vellum Bristol card stock.

\$3.00 includes shipping

*COMPLETE EXPERIMENTERS PACK* Includes *Loe Energy Wheel*®, *Hieronymous Tile* and *Symbol Pack*.

*Special \$9.95 plus \$3.00 shipping*

Check or M.O. payable to: Powell Productions

Send to:

**TOP OF THE MOUNTAIN PUBLISHING**

11701 South Belcher Road, #123

Largo, Florida 34643-5117

Fax 813 536-3681 Phone 813 530-0110

Fax, Phone or Write for FREE Catalog



# YOU CAN MOVE THINGS WITH YOUR MIND

When You Move The  
**ENERGY WHEEL®**

(PSYCHIC MOTOR) — DESIGNED BY GERALD LOE

- Extremely Sensitive
- A Repeatable Psychosynthesis Experiment — Spins from Body (LIFE) Energy
- For Fun and Bioenergy Research
- Study Strength and Control of Your Energy Field
- Control Direction of Spin through Concentration
- Some Spin it at a Distance
- Some Spin it under Glass
- Practice with the Energy Wheel® may Increase Your Healing Abilities
- Fits into Pocket or Purse
- Instruction Sheet Included

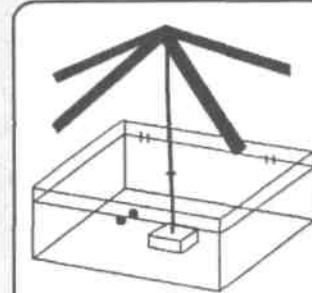

Large 2½" Rotor \$5.95  
Complete with plastic  
carrying case\stand.  
Shipping \$3.00 additional

## THE ENERGY WHEEL®

This is a device which is intended to research the visible indication of the energy flows around a living body, particularly the hands, and to show you how your mind may be able to control these flows. A few, simple experiments can prove to you that *the action of this wheel cannot be explained by standard scientific theories today, and that anybody can move matter with the mind.*

The energy which moves the wheel is believed to be identical with healing or life energy, which yogis call Prana; also called Orgone or Chi. You may find that deep breathing increases your ability to move the wheel.

Order from Top Of The Mountain Publishing

NEW THOUGHT/SCIENCE

\$11.95

***How would you like to move things with your mind?***

These "impossible" Mind Machines are easy to build, and by all scientific standards should not work... *but they do*. In some cases they seem to amplify your mind power. And the fun part is, most of these amazing Mind Machines can be *easily* built from things you have around the house.

Scientist G. Harry Stine

guides you step-by-step in the easy building and the using of these Mind Machines. He then compares their seemingly unexplainable action to current scientific knowledge. The latest research will help you to understand and use these centuries-old items, like *dowsing rods*, *pendulums*, and *pyramids*.

You will explore modern-day *Psychokinesis*, moving things with your mind, with the *Independent Suspension Pendulum* and the *Energy Wheel*. **Yes, you can move things with your mind.** You will learn how to make and use symbols that strengthen and weaken the body. Learn how to detect a friend's illness living miles away with the *Hieronymous machine*. And how to seemingly amplify your mind power to make things happen with the "unbelievable" *Wishing machine*.

Sound impossible? Build these amazing machines and prove it to yourself. Science still doesn't know why some of these machines work, but G. Harry Stine believes that finding out may lead to one of **the biggest scientific breakthroughs of the twenty-first century!**

"A vastly entertaining book. Certainly, one has to assume that our universe is bursting with scientific discoveries still to be made, and my good friend G. Harry Stine offers here much fun to all of us who refuse to believe that everything worthwhile has by now been discovered."

-Gene Roddenberry  
creator of *Star Trek*



G. HARRY STINE