



# Emergency Powers, Public Health and COVID-19

Research Paper  
No. 2, August 2020

Holly Mclean and Ben Huf  
Research & Inquiries Unit  
Parliamentary Library & Information Service

Department of Parliamentary Services  
Parliament of Victoria



## Acknowledgments

The authors would like to thank Debra Reeves, Caley Otter, Meg Bosanko, Annie Wright and Marianne Aroozoo for their help in the preparation of this paper.

*Cover image source: freepik.com*

ISSN 2204-4752 (Print) 2204-4760 (Online)

Research Paper: No. 2, August 2020

© 2020 Parliamentary Library & Information Service, Parliament of Victoria



Research Papers produced by the Parliamentary Library & Information Service, Department of Parliamentary Services, Parliament of Victoria are released under a [Creative Commons 3.0 Attribution-NonCommercial-NoDerivs licence](#).

By using this Creative Commons licence, you are free to share - to copy, distribute and transmit the work under the following conditions:

- **Attribution** - You must attribute the work in the manner specified by the author or licensor (but not in any way that suggests that they endorse you or your use of the work).
- **Non-Commercial** - You may not use this work for commercial purposes without our permission.
- **No Derivative Works** - You may not alter, transform, or build upon this work without our permission.

The Creative Commons licence only applies to publications produced by the Library, Department of Parliamentary Services, Parliament of Victoria.

All other material produced by the Parliament of Victoria is [copyright](#). If you are unsure, please [contact us](#).

# Contents

---

- Executive Summary ..... 1
- Abbreviations ..... 2
- Introduction ..... 3
- 1. Emergency powers: the broader landscape** ..... 4
  - 1.1 What are emergency powers? ..... 4
  - 1.2 Emergency powers and democracy ..... 4
  - 1.3 Who is responsible? ..... 5
  - 1.4 Emergency powers in Victoria and other states ..... 6
    - Emergency Management Acts ..... 6
    - Public Health Acts..... 7
    - Declaring multiple emergencies..... 7
  - 1.5 The role of the Commonwealth Government..... 8
    - Constitutional issues ..... 9
    - Nationalising emergencies? ..... 9
- 2. Emergency powers and COVID-19** ..... 10
  - 2.1 International agreements..... 11
  - 2.2 Federal powers..... 11
    - Coordinating a national health emergency..... 12
    - Coordinating COVID-19: Commonwealth responses ..... 15
    - Quarantine powers and the *Biosecurity Act 2015* (Cth) ..... 18
    - COVID-19 as a human biosecurity emergency..... 20
  - 2.3 Victorian powers ..... 23
    - Emergency management in Victoria ..... 23
    - Managing COVID-19 in Victoria..... 25
    - Public Health and Wellbeing Act 2008* (Vic)..... 26
    - COVID-19 as a Victorian public health emergency ..... 28
    - COVID-19 as a Victorian ‘state of disaster’ ..... 34
- 3. Tensions and issues** ..... 35
  - 3.1 Constitutional matters ..... 36
    - Border closures ..... 36
    - Biosecurity Act..... 38
    - Financing emergency responses ..... 40
  - 3.2 Rights and privacy ..... 41
    - COVID-19 and Victoria’s Charter of Human Rights ..... 41
    - Biosecurity Act and human rights ..... 42

3.3 Emergency administration: centralising tendencies? .....	44
National Cabinet and the abolition of COAG .....	44
Challenging state and federal responsibilities .....	46
<b>4. Other Jurisdictions</b> .....	50
Appendix: Chronology of Directions made by Victorian Government in response to COVID-19 pandemic .....	53
References.....	61

# Executive Summary

---

The COVID-19 pandemic has caused a remarkable suspension of everyday life. In Victoria, as around the world, the source of that suspension has been the use of wide-ranging emergency powers to slow the spread of the virus.<sup>1</sup> Many of these powers have never been used prior to COVID-19 or remain untested at law. While the 2020 pandemic has been a period of extraordinary social and economic upheaval, it has also been a significant legislative and constitutional event, testing the limits of emergency powers in Australia's federal system.

This paper describes and contextualises the kinds of powers used by the Victorian and Commonwealth governments during COVID-19. It is intended as both a resource that captures Victoria's emergency response to COVID-19 and a primer on some of the wider issues potentially related to that response.

The first section outlines the broader landscape of emergency powers in Victoria and Australia. Most modern democracies provide a range of special powers that set aside constitutional norms to respond to emergency situations and threats. As such, the use of emergency powers tends to raise vexing questions about the balance between the rule of law and security. In federal systems such as in Australia it also poses issues for the distribution of power between national, state and territory governments. In Australia, emergency powers tend to be provided for by state legislation, such as Victoria's *Emergency Management Act 2013* and the *Public Health and Wellbeing Act 2008*. The latter has been the source of the Victorian Chief Health Officer's extraordinary powers during COVID-19. In recent years, however, the federal government has asserted its constitutional authority and responsibility in coordinating emergency responses to deal with crises that are increasingly national in scope.

The second section maps how related legislation and administrative frameworks have been implemented in response to COVID-19 at international, national and state levels. The design and timing of Australia's response is shaped by its commitment to the World Health Organization's *International Health Regulations*, which informs Australia's extensive intergovernmental emergency framework. COVID-19 has activated these national frameworks but also initiated significant administrative innovation, most notably the creation of a 'National Cabinet' that has enabled the federal government to lead a coordinated response. Widespread social and economic lockdown has been imposed through determinations made using emergency powers under the Biosecurity Act (at a Commonwealth level) and Victoria's Public Health and Wellbeing Act (at a state level). The extent of the powers available under these Acts, and the determinations issued during COVID-19, are detailed in this section.

The final section considers some of the constitutional, human rights and administrative issues associated with the exercise of emergency powers, both generally and as flagged by legal experts during COVID-19.

This paper reflects the emergency response to COVID-19 up to 3 August 2020.

---

<sup>1</sup> For a global context, see A. Greene (2020) '[State of emergency: how different countries are invoking extra powers to stop the coronavirus](#)', *The Conversation*, 31 March.

## Abbreviations

---

<b>ADF</b>	Australian Defence Force
<b>AGCC</b>	Australian Government Crisis Committee
<b>AGCMF</b>	Australian Government Crisis Management Framework
<b>AHMPPI</b>	<i>Australian Health Management Plan for Pandemic Influenza (2014)</i>
<b>AHPPC</b>	Australian Health Protection Principal Committee
<b>CCC</b>	Crisis Coordination Centre
<b>CD Plan</b>	<i>Emergency Response Plan for Communicable Disease Incidents of National Significance (2016)</i>
<b>CHO</b>	Chief Health Officer (Victoria)
<b>CMO</b>	Chief Medical Officer (Commonwealth)
<b>COAG</b>	Council of Australian Governments
<b>DHHS</b>	Department of Health and Human Services (Victoria)
<b>EMC</b>	Emergency Management Commissioner
<b>EMV</b>	Emergency Management Victoria
<b>IHR</b>	International Health Regulations
<b>National CD Plan</b>	<i>Communicable Disease Incidents of National Significance: National Arrangements: National CD Plan (2018)</i>
<b>NCC</b>	National Crisis Committee
<b>NCS</b>	National Security Committee of Cabinet
<b>PHW Act</b>	<i>Public Health and Wellbeing Act 2008 (Vic)</i>
<b>SHERP</b>	State Health Emergency Response Plan (Victoria)
<b>VHMPPI</b>	Victorian Health Management Plan for Pandemic Influenza
<b>WHO</b>	World Health Organization



# Introduction

---

On 5 January 2020, the World Health Organization (WHO) notified member states that an outbreak of pneumonia of unknown cause had been identified in Wuhan City, China. By late January, cases had also been reported in Korea, Japan, Thailand and Singapore. The WHO declared a Public Health Emergency of International Concern on 30 January, following cases reported in five WHO regions in a single month. On 11 February, the WHO announced the novel coronavirus had been classified as SARS-CoV-2, causing the disease COVID-19. The WHO declared the disease a pandemic on 11 March 2020.<sup>2</sup>

Australia's first case of COVID-19 was recorded by Victorian authorities on 25 January—a passenger who travelled from Guangdong, China, to Melbourne on 19 January.<sup>3</sup> This outbreak, together with the WHO's declarations, set off a chain reaction as Australia's federal, state and territory governments implemented emergency plans to combat the spread of the virus. State and federal health agencies began meeting daily from late January, travel restrictions were imposed and national coordination arrangements implemented. On 16 March, Victoria declared a 'state of emergency' under the *Public Health and Wellbeing Act 2008* (Vic).<sup>4</sup> On 18 March, the Governor-General declared a 'human biosecurity emergency' across Australia under the *Biosecurity Act 2015* (Cth).<sup>5</sup> These declarations conferred extraordinary powers on the Victorian Chief Health Officer and Commonwealth Health Minister, respectively, who issued determinations that successively locked down Victoria and Australia's society and economy to minimise the rate of infection. COVID-19 marks the first time that the emergency powers have been activated under these Acts.<sup>6</sup> On 2 August, a 'state of disaster' was also declared in Victoria under the *Emergency Management Act 1986*, giving police greater power to enforce public health directions.<sup>7</sup>

Accordingly, while COVID-19 has caused extraordinary economic and social upheaval, it has also been a significant constitutional event. Authorities have been empowered to impose restrictions on individual freedoms and movement that suspend constitutional norms, using directions that circumvent normal parliamentary scrutiny.

The use of emergency powers had already gained public attention across Australia during the 2019–20 bushfire season, when a 'state of disaster' was declared in Victoria for the first time under the state's Emergency Management Acts.<sup>8</sup> At that time, Prime Minister Scott Morrison also called for Commonwealth capacity to declare a generalised national state of emergency.<sup>9</sup> The exercise of special powers under the states' Public Health Acts and the federal Biosecurity Act during COVID-19 has now further tested tensions that legal experts have long identified as inherent to emergency law, and its impacts on the distribution of power across the Australian federation.

---

<sup>2</sup> World Health Organization (2020) [Timeline of WHO's response to COVID-19](#), media release, 29 June.

<sup>3</sup> Department of Prime Minister and Cabinet (2020) 'Whole-of-Government Submission', *Inquiry into the Australian Government's response to the COVID-19 pandemic*, Canberra, The Committee, p. 3.

<sup>4</sup> Premier of Victoria (2020) [State of Emergency Declared in Victoria Over COVID-19](#), media release, 16 March; Victorian Government (2020) *Victoria Government Gazette*, no. s 129, 16 March.

<sup>5</sup> Prime Minister of Australia (2020) [Update on coronavirus measures](#), media statement, 18 March; Biosecurity (Human Biosecurity Emergency) (Human Coronavirus with Pandemic Potential) Declaration 2020.

<sup>6</sup> H. Maclean and K. Elphick (2020) [COVID-19 Legislative response—Human Biosecurity Emergency Declaration Explainer](#), Canberra, Australian Parliamentary Library; Justice Connect (2020) [How the Victorian Government's Emergency Restrictions on COVID-19 \(Coronavirus\) work](#), website, 29 June.

<sup>7</sup> Premier of Victoria (2020) [Statement on Changes to Melbourne's Restrictions](#), media release, 2 August.

<sup>8</sup> Premier of Victoria (2020) [Victorian Government Declares A State Of Disaster](#), media release, 2 January.

<sup>9</sup> Victorian Government (2020) *Victoria Government Gazette*, no. s 4, 3 January, p. 1; Z. Hope (2020) 'State of disaster: Premier invoked powers for first time amid bushfire crisis', *The Age*, 2 January.

This paper describes and contextualises the kinds of powers used by the Victorian and Commonwealth governments during the COVID-19 pandemic. It is intended as both a resource that captures the emergency response to COVID-19 and a primer on some of the wider issues related to that response.

The paper has three sections. The first section describes the broader landscape of emergency powers in Australian and Victoria. This section draws attention to the tension between emergency powers and normal democratic processes; the distinctive nature of public health emergency powers; and recent trends in centralising emergency powers in the hands of the federal government.

The second section looks in greater detail at the biosecurity and public health emergency powers available to the Australian and Victorian governments, and how they and other emergency frameworks have been implemented in response to COVID-19.

The final section contextualises the use of these powers within a wider set of constitutional, human rights and administrative issues that experts have raised in relation to the COVID-19 response.

This paper focuses on the use of public health emergency powers. It does not consider in detail the workings of a 'state of disaster' declared under the *Emergency Management Act 1986* (Vic). It does not cover the wider health, economic and social assistance measures to counteract the dislocations of lockdown. These measures have been extensively considered (in Victoria) by the Public Accounts and Estimates Committee and (nationally) by the Commonwealth Senate Select Committee on COVID-19. Details on emergency directions and developments are current at the time of publication, 5 August 2020.

## 1. Emergency powers: the broader landscape

---

### 1.1 What are emergency powers?

Most modern democracies have a range of special powers available to respond to emergencies that threaten safety, property or the integrity of the state. Invoking these powers sets aside the normal workings of legislative and executive powers established by a state's constitution and concentrates broad regulation-making powers in an official within the executive government. Once these special powers are triggered, the executive government is typically authorised to make regulations with respect to anything deemed necessary to respond to that emergency, often free from normal processes of parliamentary scrutiny.<sup>10</sup> In Australia, these powers are provided for by emergency legislation or clauses within legislation that are activated by the declaration of a 'state of emergency'.

### 1.2 Emergency powers and democracy

As emergency law suspends aspects of the normal distribution of constitutional power, it is a highly contested component of Australia's legislative system. Emergency laws gain democratic legitimacy because they are provided for by legislation created through the ordinary law-making processes carried out by elected representatives. This legislative approach to emergency powers bears risks. By couching extraordinary powers in ordinary legislation, for example, they have the potential to be

---

<sup>10</sup> For a general overview, see, H. P. Lee, M. Adams, C. Campbell and P. Emerton (2019) *Emergency Powers in Australia*, Cambridge, Cambridge University Press.



normalised.<sup>11</sup> More generally, in liberal democracies such as Australia, the very notion of emergency powers might be considered paradoxical. Not only do emergency powers enable the state to act outside the constitutional norms that give force to the legislation providing such powers, but to act outside constitutional norms that ground the very legitimacy of the state.<sup>12</sup>

By their nature, then, emergency powers raise vexing questions about balancing security with individual freedom. In a federal legal system such as Australia, it also presents challenges regarding the distribution of power between national and state legislatures, and the style of emergency response as shaped by the cultures of different public health and emergency management agencies at each level of government.<sup>13</sup> As has been the case with COVID-19, the exercise of emergency powers also often raises questions about ministerial accountability and decision-making.<sup>14</sup> Despite all this, as constitutional law experts Lee, Adams, Campbell and Emerton—authors of the authoritative textbook, *Emergency Powers in Australia* (herein after, Lee et al)—observe: ‘the remarkable trait of a liberal democracy is that while the powers to cope with [an] emergency provide the potential for authoritarian rule, such powers are terminated with the restoration of normalcy’.<sup>15</sup>

### 1.3 Who is responsible?

In Australia, declaring and responding to emergencies has traditionally been the responsibility of the states and territories. State parliaments exercise plenary powers, meaning they can legislate on any matter other than those matters over which the Commonwealth has exclusive power.<sup>16</sup> Accordingly, the states are generally free to define an ‘emergency’ as they see fit, and delegate special powers in line with that definition. States are constrained only by the limited freedoms guaranteed by the Australian Constitution, areas which the Constitution specifies as the responsibility of the Commonwealth Government (such as quarantine) and the requirement that parliaments do not permanently abdicate their legislative powers.<sup>17</sup>

The Australian Constitution does not provide the Commonwealth Government with a core or general ‘emergency power’ with which to respond to exceptional threats and crises.<sup>18</sup> Rather, special powers are provided for in ordinary and typically state-level legislation that defines the conditions under which specific kinds of emergencies might be declared. In the absence of fixed definitions, legal scholars tend to classify three kinds of emergency that might necessitate the use of such powers: ‘wartime’ emergencies; emergencies pertaining to ‘serious civil disturbances’, including treason, sabotage or

---

<sup>11</sup> S. Mueller (2016) ‘Turning emergency powers inside out: are extraordinary powers creeping into ordinary legislation?’, *Flinders Law Journal*, 18, pp. 295–319.

<sup>12</sup> Lee et al. (2019) op. cit., p. 3.

<sup>13</sup> B. Bennett, T. Carney and R. Bailey (2012) ‘Emergency Powers & Pandemics: Federalism and the Management of Public Health Emergencies in Australia’, *The University of Tasmania Law Review*, 31(1), p. 38.

<sup>14</sup> For example: A. Edgar (2020) ‘Law-making in a crisis: Commonwealth and NSW coronavirus regulation’, *Australian Public Law*, 30 March; L. Minshull and B. Brown (2020) *Parliamentary scrutiny during the COVID-19 crisis in Tasmania*, The Australia Institute; Joo-Cheong Tham (2020) ‘COVID-19 ministerial powers need to be reined in’, *Canberra Times*, 27 April.

<sup>15</sup> Lee et al. (2019) op. cit., p. 3.

<sup>16</sup> As discussed below, state laws will yield to those of the Commonwealth where an inconsistency arises under section 109 of the Australian Constitution.

<sup>17</sup> Lee et al. (2019) op. cit., p. 7.

<sup>18</sup> Section 51(vi) provides a defence power, enabling the Commonwealth Government to make ‘laws for the peace, order and good government of the Commonwealth’. For applications in World War II, for example, see I.M. O’Brien (2007) ‘Citizenship, Rights and Emergency Powers in Second World War Australia’, *Australian Journal of Politics and History*, 53(2), pp. 207–222.

terrorism; and ‘civil emergencies’, including from natural, medical and industrial disasters, strikes in essential services, and economic emergencies.<sup>19</sup>

The range of Australia’s emergency powers for addressing such threats has become more complex in recent decades. Since the terrorist attacks of September 11 2001, and the subsequent ‘war on terror’ waged by countries including Australia, most academic commentary and political debate has centred on the implications of new legislation that provides authorities with sweeping powers to counter terror activities. In this context, the Commonwealth Government has sought to significantly expand its powers dealing with these threats.<sup>20</sup> In Australia, as elsewhere, this legislative activity has raised repeated concerns about the potential imbalances between public safety and the rule of law.<sup>21</sup>

Emergency powers have also undergone significant change in response to the increased incidence of natural disasters, including the 2009 Black Saturday bushfires and 2019–20 bushfires, and warnings by global health authorities of the likelihood of a global pandemic. Over the past few decades, all states and territories have introduced new emergency management legislation as well as public health legislation with clauses containing emergency powers to deal with such disasters.

## 1.4 Emergency powers in Victoria and other states

Emergency powers are not new. In Australia, special powers resemble the broad framework provided for by the *Emergency Powers Act 1920* (UK).<sup>22</sup> In Victoria, such powers were first provided by the *Public Safety Preservation Act 1923*, which empowered the Governor in Council to issue a ‘proclamation of emergency’ of up to one month’s duration, enabling the issuing of regulations for securing ‘public safety or order’.<sup>23</sup> This legislation was consolidated in 1928 and again in 1958, with the latter still in force.<sup>24</sup> The *Essential Services Act 1958* (Vic) similarly empowers the Governor in Council to declare a state of emergency when essential services appear threatened, such as during industrial action. Similar powers are available under the *Fuel Emergency Act 1977* (Vic). A state of emergency was last declared under this Act in 2004, in response to a hospital shortage of coal briquettes.<sup>25</sup>

### Emergency Management Acts

In practice, these laws have now been largely superseded by Victoria’s Emergency Management Acts, as well as the powers vested in other specific legislation, such as the *Public Health and Wellbeing Act 2008* (see below). Victoria’s *Emergency Management Act 1986*, which replaced the *State Disasters Act 1983*, was enacted following the Ash Wednesday bushfires in 1983, to provide a legislative foundation

---

<sup>19</sup> Lee et al. (2019) op. cit., p. 6.

<sup>20</sup> P. Larkin and J. Uhr (2009) ‘Bipartisanship and Bicameralism in Australia’s ‘War on Terror’: Forcing Limits on the Extension of Executive Power’, *The Journal of Legislative Studies*, 15(2-3), pp. 239–256.

<sup>21</sup> See, for example, B. Golder and G. Williams (2006) ‘Balancing the national security and human rights: Assessing the legal response of common law nations to the threat of terrorism’, *Journal of Comparative Policy Analysis: Research and Practice*, 8(1), pp. 43–62; A. Neal (2012) ‘Normalization and Legislative Exceptionalism: Counterterrorist Lawmaking and Changing Times of Security Emergencies’, *International Political Sociology*, 6, pp. 265–266. D. Dyzenhaus (2006) *The Constitution of Law: Legality in a Time of Emergency*, Cambridge, Cambridge University Press; O. Gross and F. Ní Aoláin (2009) *Law in Times of Crisis: Emergency Powers in Theory and Practice*, Cambridge, Cambridge University Press.

<sup>22</sup> Lee et al. (2019) op. cit., p. 180.

<sup>23</sup> Public Safety Preservation Act 1923 (Vic), s 3.1, s 4(a).

<sup>24</sup> Public Safety Preservation Act 1928 (Vic); Public Safety Preservation Act 1958 (Vic).

<sup>25</sup> Victorian Government Gazette (2004) *Fuel Emergency Act 1977: Proclamation*, no. 7, 15 January; ABC News (2004) ‘Hospital’s coal briquettes shortage proves costly’, *ABC News*, 13 January.

for an ‘all agencies approach’ to hazards and emergencies.<sup>26</sup> It is now complemented by the *Emergency Management Act 2013*, enacted after the 2009 Black Saturday bushfires and the 2010–11 and 2011–12 floods in regional Victoria. The 2013 Act followed successive inquiries—including a royal commission and white paper—that recommended a new overarching policy framework and centralised operational control.<sup>27</sup>

These changes in Victoria reflect a general pattern in emergency power legislation by other state and territory governments in recent decades. All states and territories have now passed similarly titled Emergency Management Acts.<sup>28</sup> This legislation is intended to standardise the bureaucratic management of emergencies across Australia by creating new advisory councils, agencies and plans, including a dedicated Emergency Commissioner who is responsible for overseeing and coordinating agency functions. These frameworks are designed to guide the exercise of emergency powers by public officials.<sup>29</sup> By diffusing emergency powers throughout a group of responsible public officers and bureaucratic structures, lawmakers have sought to make it difficult for one or a small group of political officers (Ministers) to concentrate power and weaken democratic processes.<sup>30</sup>

## Public Health Acts

In addition to emergency management legislation, states, territories and the Commonwealth Government have also enacted laws that provide special powers to address specific types of emergencies. These laws often reflect global agreements, led by agencies such as the WHO. Specific cases include environmental emergencies, chemical, biological, radiological and nuclear emergencies and, as is our focus in the remainder of this paper, public health and biosecurity emergencies.<sup>31</sup>

All states and territories have passed Public Health Acts with provisions for declaring a ‘state of [public health] emergency’ and attendant emergency powers.<sup>32</sup> In Victoria, these are embodied in the *Public Health and Wellbeing Act 2008*, while the Commonwealth Government has passed the *Biosecurity Act 2015*. Both Acts are discussed in detail [below](#).

## Declaring multiple emergencies

Emergencies can be declared under both kinds of Acts. For example, Victoria’s *Emergency Management Act 1986* empowers the Premier to declare a ‘state of disaster’, following consultation with relevant ministers and the Emergency Management Commissioner.<sup>33</sup> On declaring a ‘state of

---

<sup>26</sup> Victorian Bushfire Royal Commission (2010) *Interim Report: Ch 10, Emergency Management*, Melbourne, Government Printer, p. 262.

<sup>27</sup> These included: Victorian Bushfires Royal Commission (2010) *Final Report: Summary*, Melbourne, Government Printer; N. Comrie (2011) *Review of the 2010-11 Flood Warnings & Response: final report*, Melbourne, The Review.

<sup>28</sup> Disaster Management Act 2003 (Qld); Emergency Management Act 2004 (SA); Emergency Management Act 2006 (Tas); Emergency Management Act 2005 (WA); Emergencies Act 2004 (ACT); Emergency Management Act 2013 (NT). New South Wales’ State Emergency and Rescue Management Act 1989 (NSW) is older but generally reflects the same principles and structure.

<sup>29</sup> Lee et al. (2019) *op. cit.*, pp. 180–181.

<sup>30</sup> *ibid.*, p. 182.

<sup>31</sup> *ibid.*, pp. 200–202.

<sup>32</sup> Public Health Act 1997 (ACT); Public Health Act 1997 (Tas); Public Health Act 2005 (Qld); Public Health and Wellbeing Act 2008 (Vic); Public Health Act 2010 (NSW); South Australian Public Health Act 2011 (SA); Public and Environmental Health Act 2011 (NT); Public Health Act 2016 (WA).

<sup>33</sup> Emergency Management Act 1986 (Vic), Part 5. The term ‘emergency’ is defined in section 4 as: (a) an earthquake, flood, wind-storm or other natural event; and (b) a fire; and (c) an explosion; and (d) a road accident or any other accident; and (e) a plague or an epidemic or contamination; and (f) a warlike act or act of terrorism,

disaster’, the relevant Minister is empowered to ‘direct any government agency to do or refrain from doing any act, or to exercise or perform or refrain from exercise or performing any function, power, duty or responsibility’, as well as take possession of property, and prevent entry or compel evacuation from a disaster area.<sup>34</sup> These powers were used for the first time in January 2020 in response to the 2019–20 bushfires.<sup>35</sup>

By contrast, a ‘state of emergency’ can be declared under Victoria’s Public Health and Wellbeing Act, as occurred in response to COVID-19.

Across the Australian states and territories, Emergency Management Acts and Public Health Acts differ in how they define and declare an emergency, who is responsible for declarations and according to what criteria, the duration of a declared emergency, and in whom those powers are vested. In most jurisdictions, both emergency and public health legislation also allows for actions to be taken that might be considered emergency-like—such as inspecting and detaining individuals without court orders—but do not require a formal declaration of emergency.<sup>36</sup>

COVID-19 has reflected these complexities. In all states and territories except New South Wales, a ‘public health emergency’ has been declared under respective Public Health Acts. In addition, Tasmania, Western Australia and South Australia have also declared a ‘state of emergency’ under their respective Emergency Management Acts, conferring special powers to police and non-health officials. New South Wales has declared neither a public health emergency nor a state of emergency but is using general powers provided by the *Public Health Act 2010* (NSW) [see [Jurisdictional Comparison](#)].

In Victoria, while a ‘state of emergency’ was initially declared under the Public Health Act, a ‘state of disaster’ under the Emergency Management Act was not. Early in the pandemic, Victoria’s Police Association asked the Premier to declare a state of disaster under the Emergency Management Act to equip Victoria Police with greater powers to enforce self-isolation and mass gathering bans.<sup>37</sup> A ‘state of disaster’ was subsequently declared on 2 August as Victoria entered ‘Stage Four’ restrictions, giving Victoria Police greater powers to enforce the public health directions.<sup>38</sup>

## 1.5 The role of the Commonwealth Government

The Commonwealth Government has traditionally supported the operation of state-declared emergencies with financial and logistical aid to the impacted state government.<sup>39</sup> However, the changing nature of emergencies in Australia posed by pandemics, terrorism and environmental disasters has resulted in a shift in the relationship between federal, state and territory governments in managing and responding to emergencies. These shifts include:

1. Standardisation of emergency legislation and bureaucratic structures in each state through Emergency Management Acts and Public Health Acts;

---

whether directed at Victoria or a part of Victoria or at any other State or Territory of the Commonwealth; and (g) a hi-jack, siege or riot; and (h) a disruption to an essential service.

<sup>34</sup> Emergency Management Act 1986 (Vic), s 24; Lee et al. (2019), pp. 185–86.

<sup>35</sup> Victorian Government (2020) *Victoria Government Gazette*, no. s 4, 3 January, p. 1; Z. Hope (2020) ‘[State of disaster: Premier invoked powers for first time amid bushfire crisis](#)’, *The Age*, 2 January.

<sup>36</sup> B. Bennett et al. (2012) op. cit., p. 38.

<sup>37</sup> R. Baker (2020) ‘[200 police staff in quarantine as union urges state-of-disaster declaration](#)’, *The Age*, 25 March.

<sup>38</sup> Premier of Victoria (2020) [Statement on Changes to Regional Restrictions](#), media release, 2 August; Victorian Government (2020) *Victoria Government Gazette*, no. s 383, p. 1

<sup>39</sup> Lee et al (2019) op. cit., p. 171.

2. Commonwealth legislation for specific kinds of emergencies of national significance, such as biosecurity emergencies;
3. The implementation of intergovernmental agreements, plans and frameworks in areas such as environment, energy security, biosecurity and public health that provide coordinated responses to emergencies, established through the former COAG system.<sup>40</sup>

## Constitutional issues

These developments partly reflect a pattern in which the Commonwealth Government has increasingly asserted its constitutional authority to coordinate emergency action, raising significant questions about the distribution of powers within the federation. For example, the constitutionality of intergovernmental agreements has been questioned by some legal scholars.<sup>41</sup> Others have asked whether a constitutionally satisfactory definition of ‘emergency’ to be implied from the Australian Constitution may yet be required.<sup>42</sup> Meanwhile, the constitutional powers with which the Commonwealth Government has legislating for emergencies—especially biosecurity emergencies—remains untested.

## Nationalising emergencies?

These issues have come to greater prominence following the 2019–20 bushfire season, and now COVID-19.<sup>43</sup> In January 2020, Prime Minister Scott Morrison proposed that the Commonwealth Government be granted capacity to declare a national state of emergency during bushfire and other disasters, with powers to call on the Australian Defence Force (ADF).<sup>44</sup> At the time, state governments opposed this expansion of federal powers into the domain of state jurisdiction.<sup>45</sup> Nevertheless, in February 2020, a Royal Commission into National Natural Disaster Arrangements was established to consider, among other aspects of bushfire disaster mitigation, the legal framework for the Commonwealth Government’s involvement in responding to national emergencies. In May 2020, the Royal Commission published an issues paper on the Constitutional Framework for the Declaration of a State of National Emergency.<sup>46</sup>

COVID-19 has further focused debate on the pragmatic need and constitutional possibility of centralising responses to emergencies and the exercise of emergency powers. This is likely to intensify questions about the balance between national security and human rights and the distribution of power in federal systems of government.

---

<sup>40</sup> For example, the Council of Australian Governments’ major agreements included: *National Strategy for Disaster Resilience* (2011); *Australian Emergency Management Arrangements* (2014); *Heads of Agreement on Commonwealth/State Roles and Responsibilities for the Environment* (1997); *Australian Energy Market Agreement* (2004); *National Health Security Agreement* (2007); *Intergovernmental Agreement on Biosecurity* (2012); *National Healthcare Agreement* (2012).

<sup>41</sup> Lee et al. (2019) op. cit., p. 171.

<sup>42</sup> C. Saunders (2005) ‘[Intergovernmental agreements and the executive power](#)’, *Public Law Review*, 16, pp. 294–313; Lee et al. (2019) op. cit., p. 7.

<sup>43</sup> Justice F. Kunc (2020) ‘Federalising” emergencies’, *Australian Law Journal*, 94(3), p. 167. See also: M. Eburn, C. Moore and A. Gissing (2019) *The potential role of the commonwealth in responding to catastrophic disasters*, Melbourne, Bushfire and Natural Hazards CRC.

<sup>44</sup> A. Livingston (2020) ‘[Morrison wants power to declare national emergencies in disasters](#)’, *Sydney Morning Herald*, 29 January.

<sup>45</sup> J. Kehoe (2020) ‘[States resist bushfire royal commission, oppose expansion of powers](#)’, *Australian Financial Review*, 14 January; N. Hondros (2020) ‘[WA Premier to oppose PM’s national state of emergency plan](#)’, *WAtoday*, 31 January.

<sup>46</sup> Royal Commission into Natural Disaster Arrangements (2020) *Issues Paper: Constitutional Framework for the Declaration of a State of National Emergency*. Canberra, Commonwealth of Australia.



## 2. Emergency powers and COVID-19

This section examines how the emergency powers and administration frameworks introduced above have been implemented in response to COVID-19.

The Victorian Government’s emergency response to COVID-19 fits within a broader framework of international plans, national committees and legislation and industry, medical and other extra-governmental networks. The complexity of pandemic preparedness and response channels is illustrated in the diagram below:<sup>47</sup>

**Figure 1. Pandemic preparedness and response communication channels**

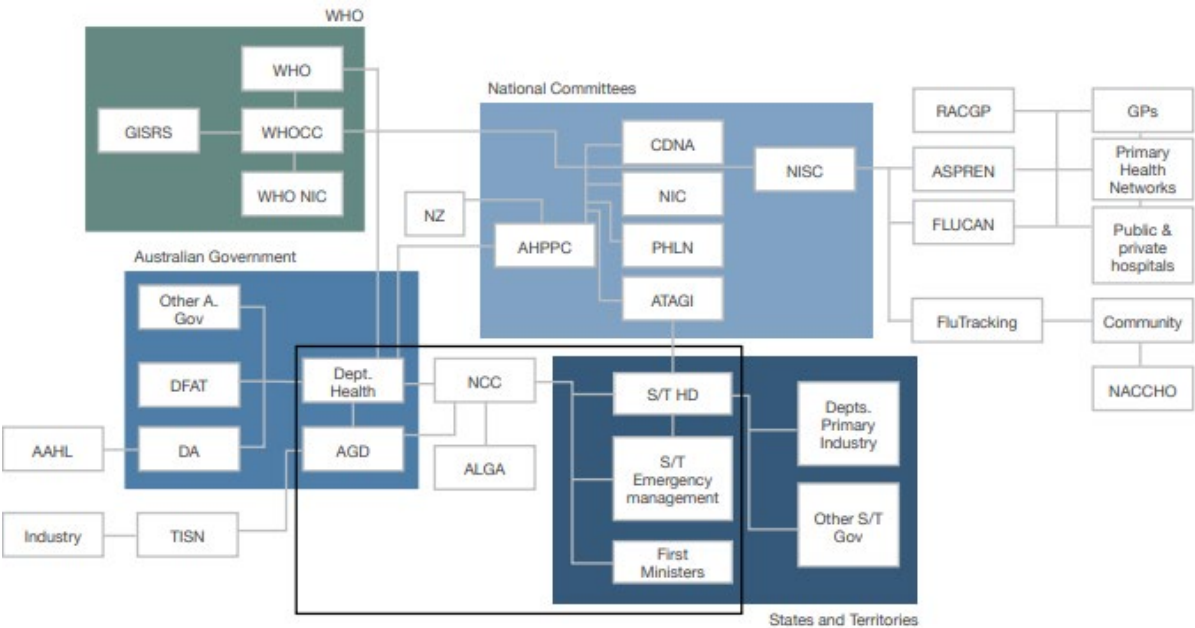

Source: Dept. of Health (2019) *Australian Health Management Plan for Pandemic Influenza*, Canberra, Commonwealth of Australia, p. 65.

The following overview focuses on the response at three main levels:

- 1) **International agreements** established by the WHO;
- 2) **Commonwealth Government** coordination and powers under the *Biosecurity Act 2015*; and
- 3) **Victorian Government** emergency frameworks and powers under the *Public Health and Wellbeing Act 2008*.

<sup>47</sup> Diagram acronyms: **WHO**: GISRS: Global Influenza Surveillance and Response System; WHOCC: World Health Organization Collaborating Centre; WHO NIC: World Health Organization National Influenza Centres. **Australian Government**: DFAT: Department of Foreign Affairs and Trade; DA: Department of Agriculture; Dept Health: Australian Government Department of Health; AGD: Attorney General’s Department. **National Committee**: AHPPC: Australian Health Protection Principal Committee; CDNA: Communicable Diseases Network Australia; NIC: National Immunisation Committee; PHLN: Public Health Laboratories Network; ATAGI: Australian Technical Advisory Group on Immunisation; NISC: National Influenza Surveillance Committee. **State and Territories**: ST/HD: State and territory health departments. **Other**: AAHL: Australian Animal Health Laboratory; ALGA: Australian Local Government Association; ASPREN: Australian Sentinel Practice Research Network; FLUCAN: The Influenza Complications Alert Network; NACCHO: National Aboriginal Community Controlled Health Organisation; NCC: National Crisis Committee; NZ: New Zealand; RACGP: Royal Australian College of General Practitioners; TISN: Trusted Information Sharing Network.



## 2.1 International agreements

Australia is a signatory to the WHO's International Health Regulations (2005). Accordingly, these regulations inform Australia's planning and frameworks for responding to public health emergencies.

International Health Regulations (IHR) were first adopted by the World Health Assembly in 1969, covering six 'quarantinable diseases'. These regulations were amended in 1973 and 1981, reducing the number of covered diseases from six to three, and to mark the global eradication of smallpox.<sup>48</sup>

In 2005, the IHR adopted a new approach to the notification of infectious diseases, moving away from a list of specified diseases to a system requiring participating countries to notify the WHO of events within their jurisdiction that may constitute a 'public health emergency of international concern'.<sup>49</sup> Such an emergency is defined in the IHR (2005) as (i) likely to constitute 'a public health risk to other States through the international spread of disease', and (ii) 'potentially require a coordinated international response'.<sup>50</sup> The regulations also require signatories to develop a domestic framework to meet this commitment and establish a National IHR 'Focal Point' responsible for liaising with the WHO.

The requirement that signatory countries develop a domestic framework to 'detect, assess, notify and report' public health risks in accordance with the IHR presupposes that these countries have a unitary or highly coordinated system of government.<sup>51</sup> As the WHO acknowledges, this can present novel challenges for federal systems of government, such as Australia. The IHR's requirement for a national focal point, for example, is not obviously reconcilable where responsibilities are diffused among national and sub-national governments.<sup>52</sup> Accordingly, Australian jurisdictions have had to implement a range of mechanisms—legislation, funding arrangements, intergovernmental agreements, and national guidelines and plans—in order to meet their IHR obligations, while also maintaining the traditional separation of powers stipulated by the Australian Constitution and state legislation.

## 2.2 Federal powers

There are two arms to the Commonwealth Government's role in responding to public health emergencies. First, it plays an important role in coordinating the various responses of the state and territory legislatures. This is achieved using intergovernmental agreements, committees, planning frameworks and funding support, which together give effect to Australia's commitment to the IHR.

Second, while the Commonwealth Government does not possess a specific public health power, the Australian Constitution does grant the Commonwealth Government powers that may be exercised to respond to a health crisis.<sup>53</sup> The most significant is the quarantine power, which today is exercised through the *Biosecurity Act 2015* (Cth).

---

<sup>48</sup> World Health Organization (2016) *International Health Regulations (2005)*. Third Edition, 1.

<sup>49</sup> *ibid.*, WHO, Art 6.

<sup>50</sup> *ibid.*, Art 1.

<sup>51</sup> *ibid.*, Art 4, Art 5, Art 13; B. Bennett et al. (2012) *op. cit.*, p. 7.

<sup>52</sup> K. Wilson, C. McDougall and R. Upshur (2005) 'The New International Health Regulations and the Federalism Dilemma', *PLoS Med* 3 no. 1: e1. See also, K. Wilson, C. McDougall, D. P. Fidler and H. Lazar (2008) 'Strategies for Implementing the New International Health Regulations in Federal Countries', *Bulletin of World Health Organisation*, March, 86(3), pp. 215–20.

<sup>53</sup> See: S. Smith (2020) 'The Scope of a Nationhood Power to Respond to COVID-19: Unanswered Questions', *Australian Public Law*, 13 May; S. Brenker (2020) 'An executive grab for power during COVID-19?', *Australian Public Law Online*, 13 May; T. Carney, R. Bailey and B. Bennett (2012) 'Pandemic planning as risk management: How fared the Australian federation?', *Journal of Law and Medicine*, 19, pp. 555–560.

Figure 2 illustrates the Commonwealth Government’s legislation and frameworks for responding to communicable disease emergencies, and its relationship to international agreements which inform state and territory responsibilities. This section addresses the Commonwealth Government’s coordinative and legislative (biosecurity) responsibilities, respectively.

**Figure 2. Interaction of legislation, frameworks and plans relevant to communicable disease**

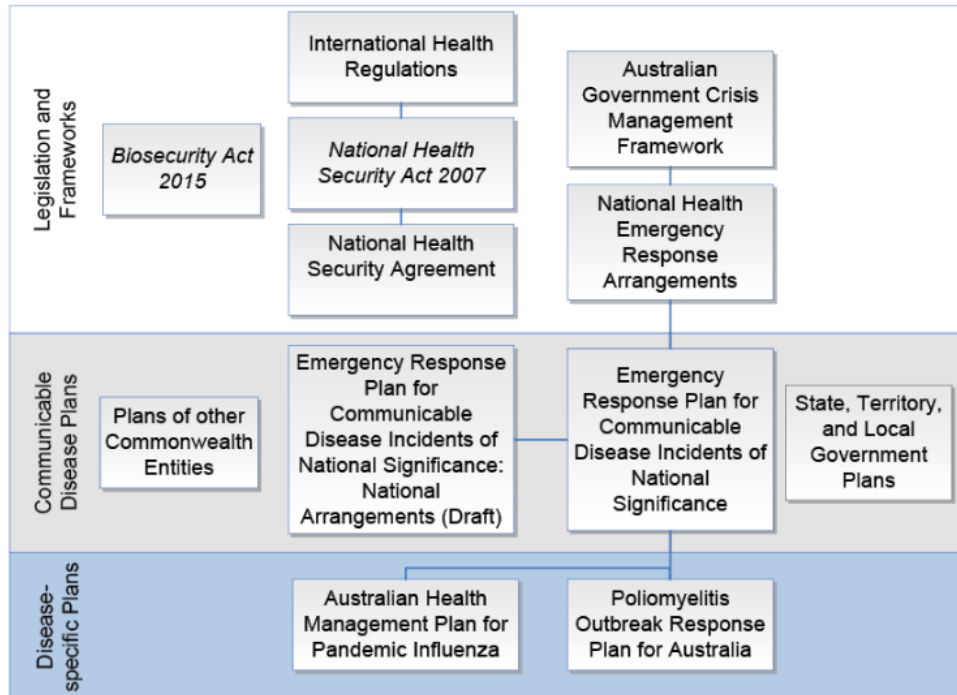

Source: Australian National Audit Office (2017) *Department of Health’s Coordination of Communicable Disease Emergencies*, Auditor-General Performance Audit, Canberra, Commonwealth of Australia, p. 18.

## Coordinating a national health emergency

There are three components to the Commonwealth Government’s coordination of public health emergencies: legislation, which gives effect to the IHR; emergency management frameworks and committees; and emergency response plans implemented by those committees.

### *National Health Security Act 2007*

The *National Health Security Act 2007* (Cth) gives effect to Australia’s commitment to the WHO’s IHR (2005). This legislation establishes a surveillance framework for coordinating and sharing information between states and the Commonwealth in response to public health emergencies. It designates the Secretary of the Department of Health as the National Focal Point, who is responsible for notifying the WHO of a ‘Public Health Event of National Significance’ or a ‘Public Health Emergency of International Concern’ and liaising between the WHO and Australian agencies in such an event.<sup>54</sup>

The Act is underpinned by the ***National Security Health Agreement (2008)***, signed by all Australian states and territories. While ceding limited powers to the Commonwealth Government to enact the Act and the associated ***National Health Security Regulations (2008)***, the agreement explicitly

<sup>54</sup> The Act also accommodates national security policy by controlling biological agents that could be used as weapons. For a discussion on the tension between the public health and security aims of the Act, see, C. Chen (2018) ‘Less is more: regulating the weaponization of disease under the National Health Security Act 2007 (Cth)’, *Journal of Law and Medicine*, 25(3), pp. 678—691.

‘recognises that the States and Territories have responsibility for responding to significant public health events within their jurisdictions’.<sup>55</sup>

*National coordination entities: frameworks and committees*

National coordination arrangements for emergencies are well established and exist independently of the National Health Security Act. Figure 3 illustrates the organisation of these entities.

**Figure 3. Decision-making committees for a communicable disease pandemic**

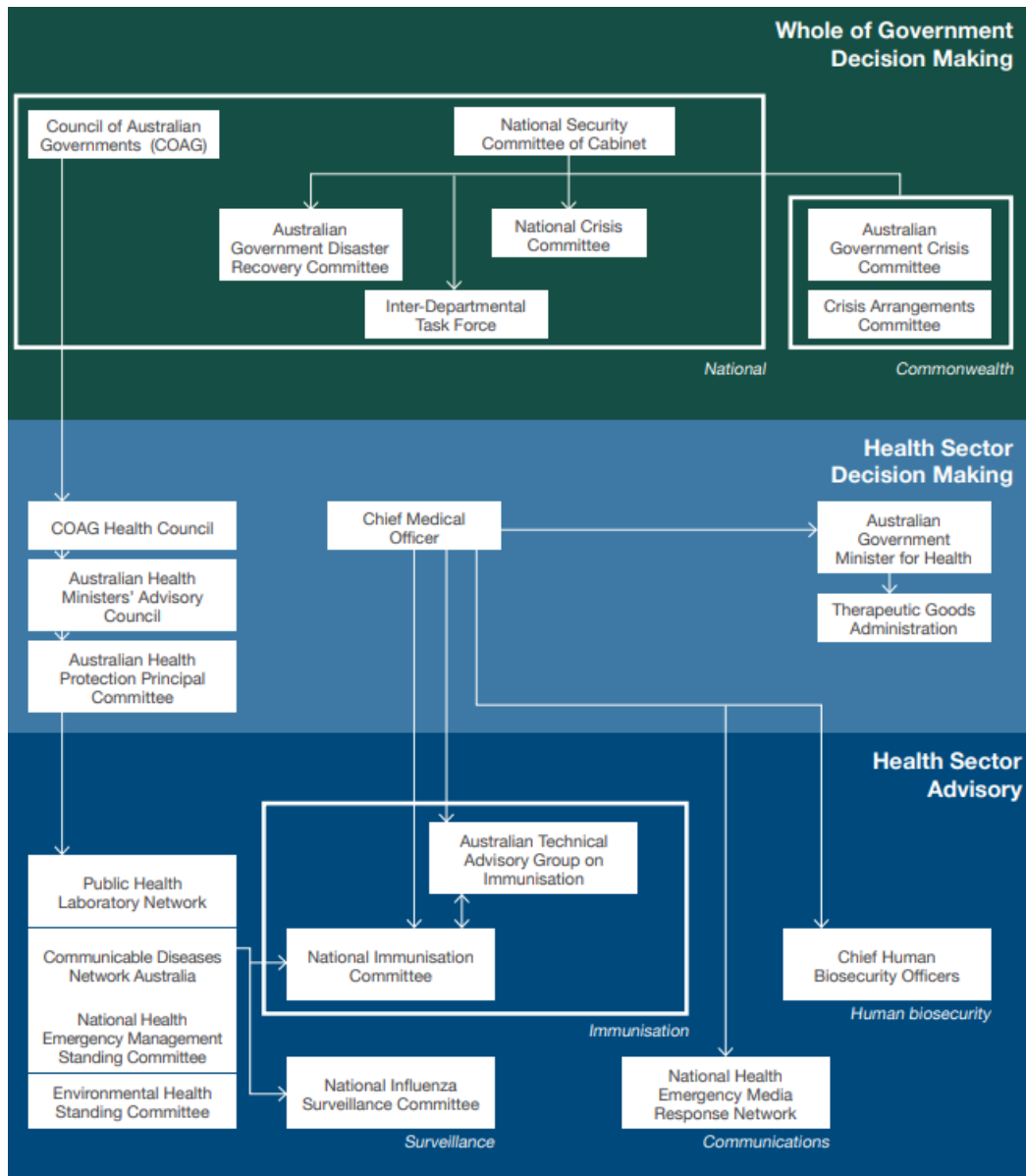

Source: Dept. of Health (2019) *Australian Health Management Plan for Pandemic Influenza*, Canberra, Commonwealth of Australia, p. 34.

The **Australian Government Crisis Management Framework (AGCMF)**, initiated in 2017, is the overarching, decision-making framework designed to manage crises of all kinds. It designates a series of key Australian and national cross-government (or ‘whole-of-government’) committees whose responsibilities are activated depending on the crisis. These include the Council of Australian

<sup>55</sup> *National Health Security Agreement (2008)*, para [21]. See also the *National Health Emergency Response Arrangements (2011)*, 10.

Governments (COAG), the National Security Committee of Cabinet (NSC), the Australian Government Crisis Committee (AGCC) and the National Crisis Committee (NCC).<sup>56</sup> COAG was permanently replaced with the National Cabinet during COVID-19. [See below](#).

At an operational level, domestic crises are coordinated by the **Crisis Coordination Centre (CCC)**, which is run by **Emergency Management Australia**, a division in the Department of Home Affairs. The CCC also manages requests made according to the Australian Government Disaster Response Plan, or COMDISPLAN (2017), which provides for non-financial assistance to Australian states and territories. It can be activated for any emergency. International crises are attended to by plans to assist other countries, evacuating persons from overseas, and dealing with mass casualty incidents overseas.<sup>57</sup>

Under the AGCMF, the **Australian Health Protection Principal Committee (AHPPC)** is the peak health emergency management committee responsible for preparing for and coordinating the response to national health crises. It consists of all state and territory Chief Health Officers and is chaired by the Australian Chief Medical Officer.<sup>58</sup> The AHPPC is responsible for high-level, cross-jurisdictional collaboration and planning. It oversees five standing committees: the National Health Emergency Management Standing Committee; the Communicable Diseases Network Australia; the Public Health Laboratory Network; the Environmental Health Standing Committee; and the Blood Borne Viruses and Sexually Transmissible Infections Standing Committee.<sup>59</sup> Prior to COVID-19, the AHPPC reported to the **Australian Health Minister's Advisory Council** and, ultimately, the **COAG Health Council**.<sup>60</sup>

The **National Incident Room** is a 24/7 communication and coordination centre located within the Department of Health. It is activated in response to national health emergencies and services the emergency meetings of the AHPPC, provides technical advice to committees and government, and coordinates deployment of the National Medical Stockpile.<sup>61</sup>

### *National health emergency plans*

The responsibilities of these committees, together with other national agencies, are set out in a series of national emergency and crisis management plans. These plans also outline how state strategies should fit into the broader national scheme. The **Australian Emergency Management Arrangements** outline broad principles for emergency management in Australia.<sup>62</sup>

The **National Health Emergency Response Arrangements** (2011) are Australia's highest-level health sector emergency plan, outlining how the Commonwealth Government, the federal Department of Health, and state and territory governments and departments work together to manage health crises. The AHPPC is the decision-making body for these arrangements.<sup>63</sup>

---

<sup>56</sup> K. Elphick (2020) *National emergency and disaster response arrangements in Australia: a quick guide*, Canberra, Australian Parliamentary Library.

<sup>57</sup> *ibid.*

<sup>58</sup> Commonwealth Department of Health (2020) *Australian Health Protection Principal Committee (AHPPC)*, website.

<sup>59</sup> *ibid.*

<sup>60</sup> Australian Institute for Disaster Resilience (2019) *Australian Disaster Resilience Handbook Collection: Health and Disaster Management*, Canberra, Department of Home Affairs, pp. 10–11.

<sup>61</sup> Elphick (2020) *National emergency and disaster response arrangements in Australia: a quick guide*, *op. cit.*

<sup>62</sup> Australian Institute for Disaster Resilience (2019) *Australian Emergency Management Arrangements*, Canberra, Department of Home Affairs, pp. 11–12.

<sup>63</sup> Australian Institute for Disaster Resilience (2019) *Australian Disaster Resilience Handbook Collection: Health and Disaster Management*, Canberra, Department of Home Affairs.

Further plans coordinate responses at lower levels (refer to Figure 2). The *Emergency Response Plan for Communicable Disease Incidents of National Significance: National Arrangements: National CD Plan* (2018), or the **National CD Plan**, outlines how non-health sector agencies (such as police, childcare, transport and essential utilities) can support the health-sector response in the event of public health crises. The *Emergency Response Plan for Communicable Disease Incidents of National Significance* (2016), or the **CD Plan**, coordinates health sector responses. A communicable disease emergency is initially managed at a local, state and territory level. Once it reaches a level that requires national coordination or inter-jurisdictional resources, it is declared a Communicable Disease Incident of National Significance (CDINS), which triggers the CD Plan (Figure 4).<sup>64</sup>

Plans have also been designed for specific crises, including the *Australian Health Management Plan for Pandemic Influenza (2019)* (AHMPPI).<sup>65</sup>

**Figure 4. Sector plans for a communicable disease incident**



Source: *Emergency Response Plan for Communicable Disease Incidents of National Significance: National Arrangements (National CD Plan)*

### Coordinating COVID-19: Commonwealth responses

From early 2020, the agreements, committees and plans described above were activated:

**Table 1. Activating the national pandemic plans**

Date	Actions
21-Jan	The Australian Chief Medical Officer (CMO) issued a determination adding 'human coronavirus with pandemic potential' to the Biosecurity (Listed Human Diseases) Determination 2016. <sup>66</sup> The listing was ahead of the WHO's declaration that the novel coronavirus outbreak was a 'Public Health Emergency of International Concern' on 30 January. The CMO's determination also activated the National Medical Stockpile, the National Trauma Centre and the National Incident Room, which serves as Australia's National Focal Point to the WHO. <sup>67</sup>
30-Jan	The AHPPC commenced daily meetings to provide governments with up-to-date advice on the crisis.

<sup>64</sup> K. Elphick (2020) *Australian pandemic response planning: a quick guide*, Canberra, Australian Parliamentary Library.

<sup>65</sup> Commonwealth Department of Health (2019) *Australian Health Management Plan for Pandemic Influenza*, Canberra, Government of Australia. Other plans include: The Domestic Response Plan for Mass Casualty Incidents of National Consequence; The Health Chemical, Biological, Radiological, Nuclear Incidents of National Significance Plan.

<sup>66</sup> *Biosecurity (Listed Human Disease) Amendment Determination 2020*

<sup>67</sup> K. Elphick (2020) *Australian COVID-19 response management arrangements: a quick guide*, Canberra, Australian Parliamentary Library.

18-Feb	The Department of Health published the <i>Australian Health Sector Emergency Response Plan for Novel Coronavirus (COVID-19) (COVID-19 Plan)</i> , which adapted the pre-existing Pandemic Influenza Plan (2018). This was designed as a 'living document that will be periodically updated' to guide the Australian health sector response to the outbreak of COVID-19. <sup>68</sup>
25-Feb	At the request of the CMO, the Australian Government activated the National CD Plan. <sup>69</sup>
5-Mar	The Australian Government commissioned the National Coordination Mechanism (NCM). Operating through the Department of Human Affairs together with states and territories, the NCM was designed to coordinate the whole-of-government response to issues outside the direct health management of COVID-19, coordinating engagement with individual sectors such as education, public safety and policing, banking, transport, food and agriculture through individual sector forums. <sup>70</sup>
13-Mar	COAG met in Sydney, agreeing 'to commission real-time, transparent protocols, underpinned by advice from the AHPPC and working through the National Coordination mechanism'. <sup>71</sup> The protocols 'included management of mass gatherings, school closures, health management in remote communities and public transport, with decisions for applying the protocols resting with states and territories'. <sup>72</sup>  COAG released the <i>National Partnership on COVID-19 Response</i> , an intergovernmental agreement outlining Commonwealth financial support to the states and territories for additional costs incurred by state health services in responding to the COVID-19 outbreak. <sup>73</sup> Under the <i>Biosecurity Act 2015</i> , this document also designates the limits of Commonwealth Government powers during a human biosecurity emergency. <sup>74</sup>

### *National Cabinet*

COVID-19 has been characterised by a notable departure from the existing plans. Following the COAG meeting, the Prime Minister also announced the formation of a crisis cabinet, known as the National Cabinet, comprising the Prime Minister, state Premiers, and territory Chief Ministers, to respond to the COVID-19 pandemic. It is the first time a crisis cabinet has been formed by a federal government that includes state and territory leaders. The AHPPC and National Coordination Mechanism were tasked with advising the National Cabinet.<sup>75</sup> The National Cabinet met for the first time on 15 March 2020.<sup>76</sup>

By the agreement of all members, the National Cabinet was constituted as a Cabinet Office Policy Committee and operated according to longstanding conventions of Cabinet government, including the guiding principles of collective responsibility and solidarity.<sup>77</sup> Accordingly, unlike COAG, where decisions are expected to be made public within a week, National Cabinet has assumed privileges of secrecy, with decisions released at the Prime Minister's prerogative.<sup>78</sup> As Chair, the Prime Minister

<sup>68</sup> Department of Health (2020) *Australian Health Sector Emergency Response Plan for Novel Coronavirus (COVID-19)*, Canberra, Australian Government.

<sup>69</sup> Meeting of the Council of Australian Government (2020) *Communique*, 13 March.

<sup>70</sup> The NCM is operating in place of National Crisis Committee (NCC) meetings due to the scale and tempo of the COVID-19 work. Under the *Australian Government Crisis Management Framework*, NCC meetings are held to coordinate efforts between the Commonwealth, states and territories in response to domestic crises; Elphick (2020) op. cit., p. 9; Department of Home Affairs (2020) *National Coordination Mechanism*, website.

<sup>71</sup> COAG (2020) *Meeting Communique*, 13 March.

<sup>72</sup> *ibid.*

<sup>73</sup> COAG (2020) *National Partnership on COVID-19 Response*, 13 March; Elphick (2020) *Australian COVID-19 response management arrangements: a quick guide*, op. cit.

<sup>74</sup> Maclean and Elphick (2020) op. cit.

<sup>75</sup> Prime Minister, Minister for Health, Chief Medical Officer (2020) *Advice on coronavirus*, media release, 13 March.

<sup>76</sup> Prime Minister of Australia (2020) *Press conference transcript*, 15 March.

<sup>77</sup> Department of Prime Minister and Cabinet (2020) 'Whole-of-Government Submission', p. 8.

<sup>78</sup> A. Schultz (2020) 'What's the difference between COAG and the national cabinet?', *Crikey*, 1 June.



provides public updates on National Cabinet decisions where appropriate.<sup>79</sup> From mid-February, heads of ministers' departments met separately to discuss COVID-19 and assist National Cabinet deliberations.<sup>80</sup>

On 29 May 2020, the Prime Minister announced that the National Cabinet model would be made permanent and known as the National Federation Reform Council, thereby abolishing COAG.<sup>81</sup>

### *National Cabinet – coordination and decisions*

National Cabinet has aimed to provide a coordinated response to COVID-19 across Australia's states and territories. While the National Cabinet made decisions designed to guide emergency responses to COVID-19, state and territory governments remained responsible for implementing these decisions using special powers available under their own emergency and public health legislation (see [Jurisdictional Comparison](#) for a list of these powers and laws).

The Victorian Government has described the National Cabinet as 'effective because it has established national principles that recognise the sovereignty of states and territories to implement policies according to local circumstances'.<sup>82</sup>

**Table 2. National cabinet decisions**

Date	Actions
15-Mar	Restrictions on mass gatherings of more than 500 people
18-Mar	Restrictions on non-essential indoor gatherings of more than 100 people
18-Mar	Restrictions on visits and arrangements at aged care facilities
18-Mar	ANZAC Day cancellations
20-Mar	Special exemptions for limitations on indoor and outdoor gatherings
20-Mar	Restrictions on travel to remote communities
22-Mar	Increased restrictions on social gatherings and selected non-essential services
24-Mar	Increase to the list of non-essential services; gatherings prohibited
27-Mar	Mandatory 14-day self-isolation in accommodation facilities for returning travellers from overseas
29-Mar	Further restrictions to indoor and outdoor public gatherings to two persons only
29-Mar	Moratorium on evictions for six months for tenants in financial distress
30-Mar	Rest stops and roadhouses exempted from restrictions on non-essential services
09-Apr	Nationally consistent approach to hardship support across the essential services for households and small businesses
09-Apr	Consistent and immediate exemption for non-cruise maritime crew to provide for the transiting to and from their place of work, within and across jurisdictions
16-Apr	Endorsed the Management and Operational Plan for COVID-19 for People with Disability
21-Apr	Allowed Category 2 and some Category 3 elective surgery to take place in public and private hospitals
24-Apr	Endorsed the updated Australian Health Protection Principal Committee advice on schools

<sup>79</sup> Department of Prime Minister and Cabinet (2020) op. cit., p. 8.

<sup>80</sup> *ibid.*

<sup>81</sup> Prime Minister of Australia (2020) *Update following national cabinet meeting*, media release, 29 May.

<sup>82</sup> Victorian Government (2020) *Submission to the Senate Select Committee on COVID-19, Inquiry into the Australian Government's response to the COVID-19 pandemic*, Melbourne, The Committee, p. 11.

1-May	Endorsed the updated Australian Health Protection Principal Committee’s medical advice on the relaxation of restriction measures
5-May	Agreed that jurisdictions will plan for and manage outbreaks in prisons in accordance with the Communicable Diseases Network Australia National Guidelines for the Prevention, Control and Public Health Management of COVID-19 Outbreaks in Correctional and Detention Facilities in Australia
8-May	Finalised a national three-step plan to gradually remove baseline restrictions and make Australia COVID-safe
15-May	Endorsed the Mental Health and Wellbeing Pandemic Plan to reduce the negative impacts of COVID-19 pandemic in the short and long term
29-May	Agreed to the formation of the National Federation Reform Council and the cessation of COAG
12-Jun	Agreed to remove the 100-person limit on non-essential indoor gatherings under the Step 3 Framework and replace it with adherence to social distancing and contact tracing principles
26-Jun	Confirmed that the current hotel quarantine arrangements remain in place, with further testing for those in quarantine

### Quarantine powers and the *Biosecurity Act 2015* (Cth)

The Commonwealth Government also has legislative capacity to respond to public health crises through the quarantine powers provided by the Australian Constitution. These powers are a legacy of nineteenth-century colonial anxieties and were a motivating factor for the colonies to federate.<sup>83</sup> Quarantine powers were exercised for over a century through the *Quarantine Act 1908* (Cth), before its repeal and replacement by the *Biosecurity Act 2015* (Cth).

#### *Quarantine Act 1908* (Cth)

The *Quarantine Act 1908* focused on preventing quarantinable diseases from breaching ports of entry into Australia. The scope of quarantine was broad and covered a range of measures to prevent or control ‘the introduction, establishment or spread of diseases or pests that will or could cause significant damage to human beings, animals, plants, other aspects of the environment or economic activities’.<sup>84</sup> The Act placed requirements on shipmasters to notify quarantine officials if they suspected symptoms of a listed disease were on board and empowered the Governor-General to declare an epidemic if satisfied that a quarantinable disease threatened the Commonwealth.<sup>85</sup> A proclamation empowered the relevant Minister to order any ‘measures incidental to quarantine’ necessary to control an epidemic.<sup>86</sup> In *ex rel Dale v Commonwealth* (1945), or ‘Pharmaceutical Benefits Case’, the High Court explicitly recognised the quarantine power as a ‘public health provision’.<sup>87</sup> However, the scope of the powers a Minister could exercise under the Act were not directly tested by the High Court throughout the twentieth century. Today, the scope of the Constitution’s quarantine power remains unclear.

By the beginning of the twenty-first century, the Quarantine Act appeared increasingly inadequate. Aircraft had long ago replaced ships as the chief mode of international transport, enabling passengers to travel long distances before realising they were sick. Moreover, while amendments had been made

<sup>83</sup> B. Huf and H. Mclean (2020) ‘Epidemics and pandemics in Victoria: Historical perspectives’, *Research Paper*, no. 1, Melbourne, Victorian Parliamentary Library, p. 27.

<sup>84</sup> Quarantine Act 1908 (Cth) s 4.

<sup>85</sup> Quarantine Act 1908 (Cth) s 22 and ss35–35A; s 13(1); and s 2B.

<sup>86</sup> Quarantine Act 1908 (Cth) s 2B and s 12B ministerial emergency directions; s 12 and s 20B declarations in relation to affected areas.

<sup>87</sup> *Attorney-General (Vic) ex rel Dale v Commonwealth* (1945) 71 CLR 237; cited in C. Pelkas (2010) ‘State Interference with Liberty: The Scope and Accountability of Australian Powers to Detain During a Pandemic’, *Flinders Law Journal*, 12(1), p. 53.

governing plants and animals, the regulation of human quarantine remained largely untouched.<sup>88</sup> A number of highly politicised incursions of exotic pests and diseases in the 1990s were followed by several major reviews—notably, the Nairn Report (1996) and the Beale Review (2008)—that recommended new risk analysis and compliance-monitoring programs. Discarding the ‘negative and defensive’ term, ‘quarantine’, for the ‘proactive and functional’ term, ‘biosecurity’, federal legislation finally passed in 2015 addressing these issues.<sup>89</sup>

### *Biosecurity Act 2015 (Cth)*

The *Biosecurity Act 2015* (Cth) reflects the commitments made in the *Intergovernmental Agreement on Biosecurity*, reached by COAG in 2012. Following the Beale Review, which recommended that ‘the Commonwealth has constitutional powers to assume a much broader biosecurity reach’ and that it take an ‘assertive national leadership role underpinned by a strong partnership with the states and territories’, it represented a marked shift in thinking about the Commonwealth’s constitutional capacities and responsibilities to deal with public health emergencies.<sup>90</sup>

The Act establishes the Director of Biosecurity (the Agriculture Secretary) and the Director of Human Biosecurity (the Commonwealth Chief Medical Officer). In consultation with the chief health officers of each state and territory and the Director of Biosecurity, the Director of Human Biosecurity is empowered to determine if a human disease ought to be listed if they consider that it is ‘communicable and may cause significant harm to human health’.<sup>91</sup>

The Act confers broad powers on the Health Minister and delegated authorities to prevent a listed human disease entering or spreading around Australia. Two types of power can be issued under the Act: **human biosecurity control orders** imposed on individuals; and the declaration of a wider-reaching **human biosecurity emergency**.<sup>92</sup>

### **Human biosecurity control orders**

Under section 60 of the Biosecurity Act, officials designated by the Chief Medical Officer can make biosecurity control orders on individuals suspected of having symptoms of a listed human disease or exposure to a person with such symptoms.<sup>93</sup> An order may require the individual to provide contact information and health details, restrict their behaviour, undergo risk-minimisation interventions including decontamination and/or medical treatment, and accept isolation from the community for specified periods.<sup>94</sup>

---

<sup>88</sup> B. Bennet (2009) ‘[Legal rights during pandemics: Federalism, rights and public health laws – a view from Australia](#)’, *Public Health*, 123(3), pp. 232–236; C. Pelkas (2010) op. cit., p. 233.

<sup>89</sup> Department of Primary Industries and Energy (1996) *Australian Quarantine a shared responsibility: The Nairn report*, Canberra, Australian Government; R. Beale, J. Fairbrother, A. Inglis and D. Trebeck (2008) *One biosecurity: a working partnership*, Canberra, Quarantine and Biosecurity Review Panel and Department of Agriculture, Fisheries and Forestry, p. x; For an account of the *Biosecurity Act 2015* (Cth) background and passage, see: T. Faunce and S. Durant (2018) ‘Analysis of Australia’s new Biosecurity Legislation’, *Journal of Law and Medicine*, 25, pp. 647–654.

<sup>90</sup> Beale et al. (2008) *One biosecurity: a working partnership*, p. x.

<sup>91</sup> Biosecurity Act 2015 (Cth), s 42.

<sup>92</sup> For a discussion, see: C. Henckels and M. O’Sullivan (2020) ‘[Explainer: what are the laws mandating self-isolation and how will they be enforced?](#)’, *The Conversation*, 17 March; and A. Maguire and B. Li (2020) ‘[Explainer: what are the Australian government’s powers to quarantine people in a coronavirus outbreak?](#)’, *The Conversation*, 4 March.

<sup>93</sup> Biosecurity Act 2015 (Cth), s 60.

<sup>94</sup> Biosecurity Act 2015 (Cth), Division 3, Subdivision B. / ss 85–97.

Human biosecurity control orders can be issued without the declaration of a biosecurity emergency. They are not legislative instruments that must be tabled in Parliament and there is no requirement to publish information about the number of orders made, or the biosecurity measures to which they relate. As such, there does not appear to be a mechanism to measure the extent to which this power is exercised.<sup>95</sup> If an individual refuses to consent to a control order, the Director of Human Biosecurity may require them to comply or be at risk of criminal offence (the maximum penalty is five years' imprisonment, a \$63,000 fine, or both). The Act also provides for a right to appeal.<sup>96</sup>

### Human biosecurity emergency

The Act provides for a second set of powers that can be exercised by declaring a human biosecurity emergency. A declaration may be made after the Minister for Health advises the Governor-General that they are satisfied that a listed human disease poses a severe and immediate threat to human health on a nationally significant scale.<sup>97</sup>

Following a declaration, the Act grants the Minister for Health expansive powers to issue any direction to any person (section 478) or determine any requirement (section 477) that the Minister deems necessary to (a) prevent or control the entry, emergence, establishment, or spread of a listed disease in Australia; (b) prevent or control the spread of a listed disease to another country; or, (c) implement a WHO Recommendation under the International Health Regulations.<sup>98</sup>

The Minister's powers under sections 477 and 478 of the Biosecurity Act are expansive. Specifically, they may be used to set requirements to regulate or restrict the movement of persons or goods, require that places be evacuated, and make directions to close premises. Moreover, these requirements and directions may be given 'despite any provision of any other Australian law'.<sup>99</sup> Emergency declarations may not last longer than three months, unless extended by the Governor-General, with each extension being for no longer than three months.<sup>100</sup>

### COVID-19 as a human biosecurity emergency

In early March 2020, following Australia's first confirmed cases of local transmission of COVID-19, the Attorney-General, the Hon. Christian Porter, announced that, as the disease had been listed under the Act's regulations, citizens could be subject to biosecurity orders to stop the spread of the virus.<sup>101</sup> Minister Porter described these powers as 'strange and foreign to many Australians'.<sup>102</sup> Media speculation followed as to what powers the Commonwealth Government possessed under the Biosecurity Act and how they might be deployed.<sup>103</sup>

---

<sup>95</sup> P. Pyburne (2020) '[COVID-19 Economic response- delegation by the Director of Human Biosecurity](#)', *FlagPost*, Australian Parliamentary Library. For a critique of lack of 'transparency', see, D. Carter (2020) 'The Use Of Coercive Public Health And Human Biosecurity Law In Australia: An Empirical Analysis', *UNSW Law Journal*, 43(1), pp. 117–153.

<sup>96</sup> *ibid.*

<sup>97</sup> Biosecurity Act 2015 (Cth), s 475.

<sup>98</sup> Maclean and Elphick (2020) *op. cit.*

<sup>99</sup> Biosecurity Act 2015 (Cth), s 478(3). Section 474 requires the Minister to exercise these powers personally; they cannot be delegated. For an overview of these provisions, see Maclean and Elphick (2020) *op. cit.*

<sup>100</sup> Biosecurity Act 2015 (Cth), s 476.

<sup>101</sup> M. Grattan (2020) '[First locally-transmitted COVID-19 cases in Australia, as Attorney-General warns drastic legal powers could be used](#)', *The Conversation*, 2 March.

<sup>102</sup> E. Bagshaw (2020) '[Strange and foreign coronavirus powers to forcibly detain Australians](#)', *The Age*, 3 March.

<sup>103</sup> For example, M. Doran (2020) '[Australians could be detained or forced into treatment to prevent the spread of coronavirus. Here's how](#)', *ABC News*, 3 March; P. Karp (2020) '[Coronavirus: what power does the Australian government have over you during crisis?](#)', *The Guardian*, 3 March.

On 18 March, the Governor-General made the Biosecurity (Human Biosecurity Emergency) (Human Coronavirus with Pandemic Potential) Declaration 2020.<sup>104</sup> On 14 May, the ‘human biosecurity emergency period’ was extended until 17 September 2020.<sup>105</sup> The COVID-19 pandemic is the first time these powers have been used under the Biosecurity Act.

*Coronavirus Economic Response Package Omnibus Act 2020*

On 23 March 2020, the Australian Parliament passed the *Coronavirus Economic Response Package Omnibus Act 2020* (Omnibus Act). Among other things, the Omnibus Act amended the *Biosecurity Act 2015* to allow the Director of Human Biosecurity—being the Australian Chief Medical Officer—to delegate some of the functions and powers in relation to human biosecurity control orders. Previously, the Act reserved these powers for the Director of Human Biosecurity.<sup>106</sup> Since these amendments, a biosecurity officer or Senior Executive Services (SES) employee can, with limited oversight, perform some of the duties reserved for the Director.<sup>107</sup>

*Biosecurity emergency directions*

The following measures have been issued under the human biosecurity emergency declaration:

**Table 3. Directions made by the Minister for Health under the *Biosecurity (Human Biosecurity Emergency) (Human Coronavirus with Pandemic Potential) Declaration 2020***

Date	Determination
<b>International cruise ship bans</b>	
18-Mar	The biosecurity emergency powers were first exercised, prohibiting international cruise ships from entering Australian ports until 15 April 2020. <sup>108</sup>
25-May	Determination was extended to 17 September 2020. <sup>109</sup>
<b>Overseas travel ban</b>	
1-Feb	Prior to the declaration, the National Security Committee of Cabinet (NSC) announced strict travel restrictions for foreign nationals entering Australia from mainland China, on advice from the CMO and AHPPC. <sup>110</sup> Self-isolation measures were also introduced, and travel warnings upgraded.
13-Feb	The NSC agreed to a further extension of travel restriction, <sup>111</sup> the evacuation of Australian passengers from the Diamond Princess cruise ship in Japan, <sup>112</sup> and changes in the level of travel advice for certain countries.
25-Mar	The Health Minister restricted Australian citizens and permanent residents from leaving Australian territory by air or sea. <sup>113</sup> Exemptions were made for persons ordinarily residing

<sup>104</sup> *Biosecurity (Human Biosecurity Emergency) (Human Coronavirus with Pandemic Potential) Declaration 2020*  
<sup>105</sup> *Biosecurity (Human Biosecurity Emergency) (Human Coronavirus with Pandemic Potential) Variation (Extension) Instrument 2020*  
<sup>106</sup> P. Pyburne (2020) ‘COVID-19 Economic response—delegation by the Director of Human Biosecurity’, 14 April.  
<sup>107</sup> COVID-19 Law monitor (2020) ‘New and Amended Commonwealth Laws’, website.  
<sup>108</sup> *Biosecurity (Human Biosecurity Emergency) (Human Coronavirus with Pandemic Potential) (Emergency Requirements) Determination 2020*  
<sup>109</sup> *Biosecurity (Human Biosecurity Emergency) (Human Coronavirus with Pandemic Potential) (Emergency Requirements for Cruise Ships) Determination 2020*  
<sup>110</sup> National Security Committee of Cabinet (2020) *Updated travel advice to protect Australians from the novel coronavirus*, media release, 1 February.  
<sup>111</sup> National Security Committee of Cabinet (2020) *Extension of travel ban to protect Australians from the coronavirus*, media release, 13 February.  
<sup>112</sup> Prime Minister Scott Morrison (2020) *Transcript press conference*, Melbourne, 17 February.  
<sup>113</sup> *Biosecurity (Human Biosecurity Emergency) (Human Coronavirus with Pandemic Potential) (Overseas Travel Ban Emergency Requirements) Determination 2020*

	outside Australia, airline employees, freight and offshores facilities, or those travelling for government business. <sup>114</sup>
<b>Access to remote communities</b>	
26-Mar	People were to remain outside certain remote communities ('designated areas'), subject to a series of exceptions. <sup>115</sup> This determination was amended on 7 April, 24 April, 24 May and 5 June. It sets out the designated areas, the requirements for persons not to enter designated areas, and nominates the relevant decision makers.
10-Jul	Determination was repealed. <sup>116</sup>
<b>Retail outlets in international terminals</b>	
28-Mar	Required most retail outlets in international terminals of Australian airports to close, albeit with some exceptions. <sup>117</sup>
<b>Essential goods</b>	
31-Mar	Prohibits the practice of price gouging and imposes requirements to ensure that those who breach relevant restrictions surrender these goods to law enforcement. It remains in force for the duration of the 'human biosecurity emergency period', which is set to end on 17 September. <sup>118</sup>
<b>COVIDSafe App</b>	
26-Apr	The Commonwealth Government launched the COVIDSafe app, which uses Bluetooth to detect and record a person's contact with other users, to provide information to support contact-tracing processes. It does not record location information. <sup>119</sup> The app is downloaded and used voluntarily. <sup>120</sup> Modelled on the Singapore app, TraceTogether, COVIDSafe had been downloaded over 6 million times by the beginning of June. <sup>121</sup>
25-Apr	The determination was made to impose strict requirements on the collection, use and disclosure of data from the COVIDSafe app, requiring users to give consent and limiting its use to supporting the state and territory health authorities' tracing efforts.
14-May	The determination was elevated into primary legislation, enshrining and extending its protections. <sup>122</sup> The <i>Privacy Amendment (Public Health Contact Information) Act 2020</i> , which amended the <i>Privacy Act 1988</i> (Cth), was intended to 'provide for a range of offences and privacy protections in relation to the collection, use, disclosure and deletion of data in connection with the COVIDSafe contact tracing app'. <sup>123</sup> These protections included extending the Privacy Act's Notifiable Data Breaches provisions to apply to the app data; obligating data to be deleted on request, and otherwise at the end of the pandemic; and requiring that the Minister for Health and the regulator submit reports regarding the app. <sup>124</sup>

<sup>114</sup> *ibid.*

<sup>115</sup> *Biosecurity (Human Biosecurity Emergency) (Human Coronavirus with Pandemic Potential) (Emergency Requirements for Remote Communities) Determination 2020*

<sup>116</sup> *Biosecurity (Human Biosecurity Emergency) (Human Coronavirus with Pandemic Potential) (Emergency Requirements for Remote Communities) Repeal Determination 2020*

<sup>117</sup> *Biosecurity (Human Biosecurity Emergency) (Human Coronavirus with Pandemic Potential) (Emergency Requirements—Retail Outlets at International Airports) Determination 2020*

<sup>118</sup> *Biosecurity (Human Biosecurity Emergency) (Human Coronavirus with Pandemic Potential) (Essential Goods) Determination 2020*

<sup>119</sup> Office of the Australian Information Commissioner (2020) 'The COVIDSafe app and my privacy rights' OAIC website.

<sup>120</sup> J. Hayne and G. Hitch (2020) 'Coronavirus app will not be forced upon Australians, Scott Morrison says', *ABC News*, 18 April.

<sup>121</sup> S. Meixner (2020) 'How many people have downloaded the COVIDSafe app and how central has it been to Australia's coronavirus response?', *ABC News*, 2 June.

<sup>122</sup> G. Hughes (2020) 'Privacy Act Amended to Regulate COVIDSafe App Data', *Davies Collison Cave*, 18 May.

<sup>123</sup> C. Petrie (2020) *Privacy Amendment (Public Health Contact Information) Bill 2020*, *Bills Digest*, Canberra, Australian Parliamentary Library.

<sup>124</sup> K. Buchanan (2015) 'Australia: legal responses to health emergencies', *Library of Congress*, online.



## 2.3 Victorian powers

Like the Commonwealth Government, Victoria's response to public health emergencies comprises two arms: emergency management procedures directed ultimately under the *Emergency Management Act 2013* (Vic) and public directions issued using emergency powers under the *Public Health and Wellbeing Act 2008* (Vic).

### Emergency management in Victoria

#### *Emergency Management Act 2013*

Victoria's *Emergency Management Act 2013* was established after the 2009 Black Saturday bushfires and 2010–12 regional floods. It made several major administrative and regulatory changes to managing emergencies, creating:

- the State Crisis and Resilience Council and subcommittees, responsible for advising government and creating an overarching strategy for emergency management;
- Emergency Management Victoria (EMV), responsible for coordinating and overseeing the roles, responsibilities and powers to be exercised by government agencies during emergencies; and
- the Emergency Management Commissioner (EMC), a statutory appointment who is responsible for preparing state emergency response plans subject to review by the State Crisis and Resilience Council and, during major emergencies, for exercising control over the response.<sup>125</sup>

The Act distinguishes between Class 1 and Class 2 emergencies as a way of designating the 'control agency' (usually a relevant government department or Victoria Police) and related responsibilities in different kinds of emergencies. Class 1 emergencies include major fires and other major emergencies for which the Metropolitan Fire and Emergency Services Board, the Country Fire Authority or the Victoria State Emergency Service Authority is the control agency under the State Emergency Response Plan. Class 2 emergencies include all other emergencies, except warlike acts, hi-jackings or sieges, which are controlled by Victoria Police.

EMV's **State Emergency Response Plan** comprises 12 sub-plans outlining responses to different kinds of emergencies, provides broader guidance during emergencies and prescribes the roles and responsibilities of agencies, and the actions they must take, in an emergency.<sup>126</sup>

#### *Public health emergency plans*

Health emergencies are classified as Class 2 emergencies. The **Emergency Management Manual Victoria (EMMV) Part 7 – Emergency Management Agency Roles** designates the Department of Health and Human Services (DHHS) as the control agency for emergencies involving biological or radioactive materials, food or drinking water contamination, and human disease.<sup>127</sup>

Under the EMV's State Emergency Response Plan, the **State Health Emergency Response Plan** (SHERP), last updated in 2017, is used by emergency services and public health workers to coordinate

---

<sup>125</sup> *Emergency Management Act 2013* (Vic).

<sup>126</sup> These include: State Biosecurity Sub-Plan; State Bushfire Plan; State Earthquake Sub-Plan; State Electricity and Gas Supply Sub-Plan; State Extreme Heat Sub-Plan; State Flood Sub-Plan; State Health Emergency Response Plan; State Maritime Emergencies (non-search and rescue) Plan; State Public Transport Disruption Sub-Plan; State Storm Sub-Plan; State Tsunami Sub-Plan; Victorian Action Plan for Pandemic Influenza. See, Emergency Management Victoria (2019) [State emergency plans](#), website.

<sup>127</sup> Emergency Management Victoria (2020) [Emergency Management Manual Victoria Part 7 – Emergency Management Agency Roles](#), Melbourne, Victorian Government, pp. 51–53.

health services for the community during emergencies.<sup>128</sup> The **Victorian Action Plan for Pandemic Influenza**, last updated in 2015, sets out Victoria’s approach for reducing social and economic impacts and consequences of a pandemic influenza on communities.<sup>129</sup>

*Managing public health emergencies*

Under SHERP, the DHHS may activate the **State Emergency Management Centre** (located at the DHHS) for the effective management of an emergency. In consultation with the EMC, it may also request the activation of the **State Control Centre** (SCC) to provide support to the **State Controller** who leads the emergency response. In an identifiable public health emergency, the Public Health Commander (a function performed by the Chief Health Officer) is appointed as the State Controller (See Figure 5).

**Figure 5. Managing public health emergencies**

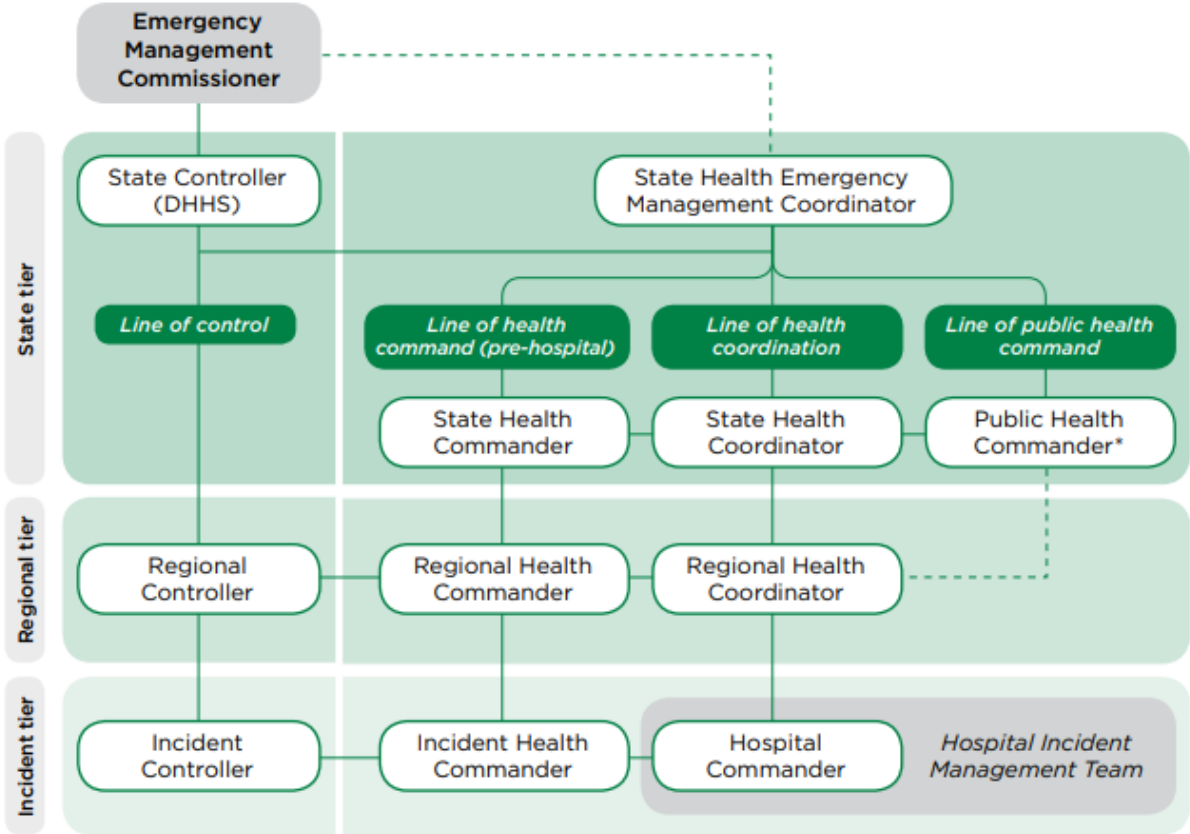

\*Public Health Commander is appointed as State Controller for identifiable public health emergencies. (The Public Health Commander function is performed by the Chief Health Officer, or delegate). Source: EMV (2017) *State Health Emergency Response Plan*, Melbourne, Victorian Government, p. 22.

Located in EMV, the SCC assists with coordinating control of emergency responses and has well-established protocols for working across all government agencies, providing information and warnings to the community, and functioning as the hub of a network of regional control centres and incident control centres across the state.<sup>130</sup>

<sup>128</sup> Emergency Management Victoria (2017) *State Health Emergency Response Plan*. Edition 4, Melbourne, Victorian Government, pp. 21–22.

<sup>129</sup> Emergency Management Victoria (2015) *Victorian action plan for influenza pandemic*, Melbourne, Victorian Government.

<sup>130</sup> *ibid.*; Emergency Management Victoria (2020) *State Control Centre (SCC)*, website.

The DHHS's *Victorian Health Management Plan for Pandemic Influenza* (VHMPPI), released in October 2014, provides a framework for government and health sector responses to an influenza pandemic. The plan builds on the foundations established by the 2007 VHMPPI, as well as plans developed by the Australian Government Department of Health and COAG. It is the local reflection of the AHMPPI and complements its content.<sup>131</sup> VHMPPI also provides a guide to local government areas to develop an influenza pandemic plan for their municipality.<sup>132</sup>

### *Hospitals and health services*

The *Health Services Act 1988* (Vic) empowers the Secretary of the DHHS to direct public hospitals (metropolitan and rural) and denominational hospitals in relation to the actions hospitals should take during an emergency. The Minister for Health may also give directions to public hospitals. The Secretary has limited powers to direct private hospitals, day procedure centres and other health service establishments to comply with standards in regulations and provide specified information.<sup>133</sup>

## Managing COVID-19 in Victoria

In February, the DHHS was appointed as the control agency with primary responsibility for responding to COVID-19 and coordinating inter-agency responses at the state level.<sup>134</sup> On 10 March, the Victorian Government released the *COVID-19 Pandemic Plan for the Victorian Health Sector*. This plan is based on principles and proposals outlined in the VHMPPI, and aligns with the Australian Health Sector Emergency Response Plan for Novel Coronavirus (COVID-19).<sup>135</sup> Under this plan, a **Departmental Incident Management Team**, chaired by the Public Health Commander (performed by the Victorian CHO) coordinates the health response of DHHS.<sup>136</sup> In addition to this plan, emergency management has been guided by SHERP, and a version of EMV's Victorian Action Plan for Pandemic Influenza adapted for COVID-19.<sup>137</sup>

On 11 March, the Premier announced the SCC would oversee and coordinate Victoria's response to the spread of COVID-19.<sup>138</sup> The SCC had already been running for eight months after being activated on 11 September 2019 to support the interstate deployment of Victorian firefighters to NSW and QLD.<sup>139</sup>

### *Government and public service*

On 3 April 2020, the Victorian Government established the Crisis Council of Cabinet (CCC) as the primary decision-making forum for the Victorian Government on all matters related to the COVID-19 emergency, including implementing the outcomes of the National Cabinet. The CCC comprised eight ministers from the Andrews Government's existing Cabinet.<sup>140</sup>

---

<sup>131</sup> Department of Health (2014) *Victorian health management plan for pandemic influenza*, Melbourne, Victorian Government.

<sup>132</sup> *ibid.*, pp. 79–82.

<sup>133</sup> J. Mikakos (Minister for Health) (2020) *COVID-19 Pandemic plan for the Victoria Health Sector*, Melbourne, Victorian Government, p. 29.

<sup>134</sup> Victorian Government (2020) *op. cit.*, pp. 8–9.

<sup>135</sup> J. Mikakos (Minister for Health) (2020) *COVID-19 Pandemic plan for the Victoria Health Sector*, *op. cit.*, pp. 4, 29.

<sup>136</sup> *ibid.*, p. 29.

<sup>137</sup> Victorian Government (2020) *op. cit.*, pp. 8–9.

<sup>138</sup> Premier of Victoria (2020) *State Control Centre Activated To Oversee COVID-19 Response*, media release, 11 March.

<sup>139</sup> EMV (2020) *Eight months of activation at the State Control Centre*, media release, 13 May.

<sup>140</sup> The Ministers and their roles are: The Hon. Daniel Andrews MP, Premier (Chair); The Hon. James Merlino MP, Minister for the Coordination of Education and Training – COVID-19; Tim Pallas MP, Minister for the Coordination

The Victorian Public Service has also been tasked to focus ‘on eight core missions to help respond to the emergency’.<sup>141</sup> The eight public service missions are: Health emergency; Economic emergency; Economic program delivery, supply, logistics, and procurement; Continuity of essential services – People; Continuity of essential services – Economic; Economic recovery (private sector); Restoration of public services – People; Restoration of public services – Economic (public sector).<sup>142</sup>

### *Local government*

The *COVID-19 Pandemic Plan for the Victorian Health Sector* instructed, ‘local councils should now implement existing pandemic plans including adapting plans for COVID-19, including business continuity plans’.<sup>143</sup> DHHS provided regular bulletins to local government that gave advice on regulations and restrictions.<sup>144</sup>

### *Changes to Victoria’s COVID-19 leadership*

At the end of July, it was reported that the Victorian Government had overhauled its COVID-19 crisis leadership. Victoria Police Chief Commissioner Shane Patton and Chief Health Officer Brett Sutton were appointed to take part in SCC meetings, with Emergency Management Commissioner Andrew Crisp appointed chair.<sup>145</sup>

### *Public Health and Wellbeing Act 2008 (Vic)*

The principal Act for public health powers in Victoria is the *Public Health and Wellbeing Act 2008*, repealing the *Health Act 1958* and modernising Victoria’s public health framework. Daniel Andrews, then the Minister for Health, outlined the purpose of the Act in the second reading, stating:

The bill provides for responses to risks to health and enables the Department of Human Services to investigate and manage these risks, through a graduated scheme that enables a proportionate response to matters ranging from small incidents to emergencies, such as an influenza pandemic. The emergency powers in the bill will complement Victoria's detailed emergency planning system ... An emergency will only be declared after consultation with the relevant authorities under the Emergency Management Act. Should that consultation determine that action is more appropriately taken under the Emergency Management Act, the Minister would not declare an emergency under these provisions. Whilst it is hoped that such an emergency will not often arise, it is essential that Victoria has the appropriate planning and legal framework to address these risks.<sup>146</sup>

---

of Treasury and Finance – COVID-19; The Hon. Jacinta Allan MP, Minister for the Coordination of Transport – COVID-19; The Hon. Jenny Mikakos MP, Minister for the Coordination of Health and Human Services – COVID-19; The Hon. Jill Hennessy MP, Minister for the Coordination of Justice and Community Safety – COVID-19; The Hon. Martin Pakula MP, Minister for the Coordination of Jobs, Precincts and Regions – COVID-19; The Hon. Lisa Neville MP, Minister for the Coordination of Environment, Land, Water and Planning – COVID-19. See: Victoria Government (2020), *Submission*, op. cit., p. 10.

<sup>141</sup> *ibid.*, pp. 10–11.

<sup>142</sup> *ibid.*

<sup>143</sup> J. Mikakos (Minister for Health) (2020) *COVID-19 Pandemic plan for the Victoria Health Sector*, op. cit., p. 24.

<sup>144</sup> Department of Health and Human Services (2020) *Coronavirus (COVID-19) Information*, website.

<sup>145</sup> M. Fowler, R. Harris and S. Ilanbey (2020) ‘Australia’s top medical experts to spend Saturday deciding further Victorian restrictions’, *The Age*, 31 July.

<sup>146</sup> D. Andrews (Minister for Health) (2008) ‘Second reading speech: Public Health and Wellbeing Bill’, *Debates*, Victoria, Legislative Assembly, 8 May, pp. 1732, 1736–7.

### *Declaring a public health emergency*

The Act empowers the Minister for Health, on the advice of the Chief Health Officer, to declare a ‘state of emergency’ to respond to public health crises that pose a ‘serious risk to public health’.<sup>147</sup> The *Emergency Management Act 2013* requires such a declaration be made in consultation with the Minister for Police and the EMC.<sup>148</sup> The Minister is required to broadcast and gazette the declaration as soon as practically possible, and table a report to Parliament on the risks of the emergency.<sup>149</sup> A declaration does not limit any provision relating to the declaration of an emergency under another Act.<sup>150</sup>

The Act requires medical practitioners and pathology services to notify DHHS of cases of specific infectious diseases. The Governor in Council can amend this list of diseases, which are listed in the Public Health and Wellbeing Regulations 2019.<sup>151</sup>

### *Emergency powers*

On declaring a state of emergency, the Chief Health Officer is provided with emergency powers to issue **directions** and set requirements to eliminate or reduce risks to public health as well as **public health risk powers**, conducted by **Authorised Officers**.

### **Public directions**

Sections 199 and 200 of the Act grant the Chief Health Officer expansive powers to issue directions and set requirements to eliminate or reduce risks to public health. These powers include:

- detaining any person or group for as long as reasonably necessary to eliminate or reduce a serious risk to public health;
- restricting the movement of any person within Victoria;
- preventing any person or group from entering Victoria; and
- giving any other direction reasonably necessary to protect public health.

The Act stipulates responsibilities for Authorised Officers in detaining individuals, how an authorised detention is to be given, penalties for the failure to comply, and compensation available if the detained person ‘considers that there were insufficient grounds for the giving of that authorisation’.<sup>152</sup>

### **Public Health Risk Powers**

Outside these emergency powers, the Act also enables the Chief Health Officer to delegate powers to Authorised Officers to investigate, eliminate, or reduce a risk to public health.<sup>153</sup> The powers, which are similar to the Commonwealth Government’s Biosecurity Control Orders, include the ability to: close premises; direct a person to enter or not enter premises; enter premises without a warrant to search and seize anything necessary; require information; inspect any premises; require cleaning or

---

<sup>147</sup> The PHW Act defines a ‘serious risk to public health’ as a ‘material risk that substantial injury or prejudice to the health of human beings has or may occur having regard to— (a) the number of persons likely to be affected; (b) the location, immediacy and seriousness of the threat to the health of persons; (c) the nature, scale and effects of the harm, illness or injury that may develop; (d) the availability and effectiveness of any precaution, safeguard, treatment or other measure to eliminate or reduce the risk to the health of human beings’. See: Public Health and Wellbeing Act 2008, s 3.

<sup>148</sup> *ibid.*, s 198(1).

<sup>149</sup> *ibid.*, ss 198(5–8).

<sup>150</sup> *ibid.*, s 198(9).

<sup>151</sup> *ibid.*, ss 126–127.

<sup>152</sup> *ibid.*, s 204.

<sup>153</sup> *ibid.*, s 189.

disinfection of premises; require the destruction or disposal of anything necessary; and direct the owner of premises or any other persons to take any action necessary.<sup>154</sup>

### Appointment of Authorised Officers

The Chief Health Officer may appoint officers to exercise any of the public health and emergency powers. Authorised Officers must produce their identity card before exercising powers under the Act, identify their card for inspection if entering a property, provide warnings that it is against the law not to follow their instructions, unless it is not practical to do so.<sup>155</sup> The Act also enables Authorised Officers to request assistance from Victoria Police.<sup>156</sup>

### Safeguards

The Act provides safeguards against the powers impinging upon individual liberties, including that: infectious disease management be governed by principles respecting personal rights; measures which least restrict the rights of a person should be chosen; and public health orders are subject to appeal, requiring a review by the Chief Health Officer within seven days.<sup>157</sup> The Act was also assessed as compatible with the state's Charter of Human Rights and Responsibilities.<sup>158</sup>

### COVID-19 as a Victorian public health emergency

On 16 March 2020, the Minister for Health, the Hon. Jenny Mikakos, declared a 'state of emergency throughout the State of Victoria', in response to 'the serious risk to public health in Victoria from Coronavirus'.<sup>159</sup> The measures were described by the Premier as necessary to help 'provide the Chief Health Officer with the powers he needs to enforce 14-day isolation requirements for all travellers entering Australia, and cancel mass gatherings of more than 500 people, as agreed by the National Cabinet'.<sup>160</sup>

The state of emergency declaration was operational for four weeks, the longest enforceable period under the Act.<sup>161</sup> At the time of writing, the state of emergency has been extended five times: on 12 April, 11 May, 31 May, 21 June and 19 July, with the latest extension to remain in force until 16 August.<sup>162</sup> Declarations may be extended for a period of up to six months.

---

<sup>154</sup> *ibid.*, s 190. See also: Justice Connect (2020) [How the Victorian Government's Emergency Restrictions on COVID-19 \(Coronavirus\) work](#), website, 29 June.

<sup>155</sup> Public Health and Wellbeing Act 2008 (Vic), ss 166, 189, 190, 199, 200.

<sup>156</sup> *ibid.*, ss 192, 202.

<sup>157</sup> Public Health and Wellbeing Act 2008 (Vic), ss 111-12, 121-22; Pelkas (2020) *op. cit.*, pp. 52, 67.

<sup>158</sup> D. Andrews (Minister for Health) (2008) '[Statement of Compatibility: Public Health and Wellbeing Bill](#)', *Debates*, Victoria, Legislative Assembly, 8 May, p. 1709.

<sup>159</sup> Victorian Government (2020) *Victoria Government Gazette*, no. s 129, p. 1.

<sup>160</sup> Premier of Victoria (2020) [State of emergency declared in Victoria over COVID-19](#), media release, 16 March.

<sup>161</sup> Public Health and Wellbeing Act 2008 (Vic), s 198(7); J. Mikakos (Minister for Health) (2020) [Report to Parliament on the declaration of a state of emergency: report under section 198\(8\) of the Public Health and Wellbeing Act 2008](#), Melbourne, Victorian Government.

<sup>162</sup> Victorian Government (2020) *Victoria Government Gazette*, no. s 193, p. 1; Victorian Government (2020) *Victoria Government Gazette*, no. s 231, p. 1; Victorian Government (2020) *Victoria Government Gazette*, no. s 267, p. 1.



**Table 4. Directions made by the Minister for Health under the Declaration of a State of Emergency**

Date	Directions
<b>Airport arrivals and cruise ship docking</b>	
18 and 19-Mar	People arriving in Victoria from overseas via aeroplane or ship, or by Australian cruise ship, must go into immediate compulsory quarantine for 14 days. <sup>163</sup>
28-Mar	Direction issued revoking the airport arrivals and cruise ship docking directions, recognising both had been superseded by the compulsory quarantine Direction and Detention notice. <sup>164</sup>
<b>Mass gatherings</b>	
18-Mar	The first mass gathering direction was issued, limiting gatherings of 500 or more in a single outdoor space, and 100 or more in an undivided indoor space. <sup>165</sup> These directions were firmed on 21 March. <sup>166</sup>
25-Mar	<i>Prohibited Gathering Directions</i> were issued, limiting the attendance at weddings, funerals and social sport gatherings. <sup>167</sup> These directions were replaced with the Stay at Home directions (below), which also restricted gatherings.
<b>Restricted activity: aged care, hospitals and businesses</b>	
21-Mar	Restrictions were placed on the types of persons accessing aged care facilities. These directions were replaced on 7 April and 13 April (and renewed on 11 May) by a new order that extended the restrictions to alcohol and drug residential services, homeless residential services and disability residential services, among others. <sup>168</sup> On 31 May, a fourth set of directions began relaxing restrictions for visits to care facilities. <sup>169</sup> The fifth directions on 21 June clarified that persons providing wellbeing support services (such as hairdressers and recreational therapies) would be allowed to enter care facilities. The sixth and seventh set of directions, introduced on 1 July and then 19 July, both emphasised the need for restricted access to facilities within 'a particularly vulnerable population'. <sup>170</sup>
23-Mar	Restrictions on non-essential hospital visits were first issued. <sup>171</sup> These were extended on 13 April and for a third time on 11 May. <sup>172</sup> The directions were relaxed on 11 and 31 May, widening the scope of permissible hospital visits. <sup>173</sup> Two further sets of <i>Hospital Visitor Directions</i> were made in the month of June, with the latest set of directions (No. 9) made on 22 July. Set to expire on 16 August, these directions expand the categories of persons excluded from entering a hospital, sets limits on the number and duration of visits to patients, and requires hospitals to keep a record of visitors. <sup>174</sup>
23-Mar	'Non-essential' businesses were directed to cease operating until 13 April. <sup>175</sup> This was replaced with <i>non-essential Activity Directions</i> on 25 and 26 March, which added to the existing category of non-essential businesses and imposed signage and cleaning requirements upon 'essential' businesses and undertakings that remained open. <sup>176</sup> Non-essential businesses and activities included, but were not limited to: licensed

<sup>163</sup> Victorian Government (2020) *Victoria Government Gazette*, no. s 135, p. 1; Victorian Government (2020) *Victoria Government Gazette*, no. s 139, p. 1.

<sup>164</sup> Victorian Government (2020) *Victoria Government Gazette*, no. s 167, p. 1.

<sup>165</sup> Victorian Government (2020) *Victoria Government Gazette*, no. s 135, p. 3.

<sup>166</sup> Victorian Government (2020) *Victoria Government Gazette*, no. s 142, p. 1

<sup>167</sup> Victorian Government (2020) *Victoria Government Gazette*, no. s. 156.

<sup>168</sup> Victorian Government (2020) *Victoria Government Gazette*, no. s 142, p. 4; Victorian Government (2020) *Victoria Government Gazette*, no. s 191, p. 1; Victorian Government (2020) *Victoria Government Gazette*, no. s 194, p. 8; Victorian Government (2020) *Victoria Government Gazette*, no. s 231, p. 16.

<sup>169</sup> Victorian Government (2020) *Victoria Government Gazette*, no. s 267, p. 2.

<sup>170</sup> Victorian Government (2020) *Victoria Government Gazette*, no. s 339, p. 55; Victorian Government (2020) *Victoria Government Gazette*, no. s 361, p. 66.

<sup>171</sup> Victorian Government (2020) *Victoria Government Gazette*, no. s 147, p. 1.

<sup>172</sup> Victorian Government (2020) *Victoria Government Gazette*, no. s 231, p. 20.

<sup>173</sup> Victorian Government (2020) *Victoria Government Gazette*, no. s 267, p. 7; Victorian Government (2020) *Victoria Government Gazette*, no. s 289, p. 1.

<sup>174</sup> Victorian Government (2020) *Victoria Government Gazette*, no. s 367, p. 62.

<sup>175</sup> Victorian Government (2020) *Victoria Government Gazette*, no. s 156, p. 1.

<sup>176</sup> Victorian Government (2020) *Victoria Government Gazette*, no. s 156, p. 4; Victorian Government (2020) *Victoria Government Gazette*, no. s 161, p. 1.

	premises; recreational facilities; places of worship; retail facilities; food and drink facilities; and entertainment and accommodation facilities. From 30 March, these directions were replaced by a series of Restricted Activity Directions. <sup>177</sup>
11-May	<p>Restrictions were eased, with Restricted Activity Directions (no. 7), permitting ten members of the public to gather publicly:</p> <ul style="list-style-type: none"> <li>▪ for religious purposes</li> <li>▪ to attend auction houses, real estate auctions and residential property inspections</li> <li>▪ to attend sport groups.</li> </ul> <p>On 24 May, restrictions were further eased with Restricted Activity Directions (no. 8) permitting ‘publicly accessible playgrounds, skateparks and outdoor communal gym equipment to operate’. On 31 May, these were updated to permit ‘up to 20 people to gather for certain activities’ and the limited operation of several facilities previously banned. Among these were dine-in services for food and drink, swimming pools, beauty and personal care facilities and entertainment facilities.<sup>178</sup> A tenth direction on 22 June permitted, among other businesses and undertakings, ‘limited operation of certain physical recreational facilities, cinemas, licensed premises and retail betting venues’.<sup>179</sup> The eleventh directions on 2 July imposed a density quotient on markets and retail shopping centres, which limited members of the public permitted in these public spaces. The 12th through to the 15th set of Directions imposed, among other things, ‘obligations on certain facilities and accommodation providers to use reasonable endeavours to ascertain that the principle place of residence of customers is not in a restricted area’.<sup>180</sup> The current Directions, which are set to expire 16 August, impose an obligation on employers to ensure employees wear face coverings.<sup>181</sup></p>
<b>Self-isolation</b>	
25-Mar	<p>Direction issued requiring persons diagnosed with COVID-19 to isolate to limit the spread of the virus. A second direction was issued on 13 April, extending the enforcement until 11 May. It provided that:</p> <ul style="list-style-type: none"> <li>▪ A person who is diagnosed with COVID-19 in the State of Victoria must return to and remain at the place in which they reside (self-isolation);</li> <li>▪ They must not leave the premises except for the purpose of obtaining medical care or medical supplies, in any other emergency situation, or in limited outdoor circumstances where it is possible to avoid close contact with any other persons;</li> <li>▪ They must not permit other persons to enter the premises unless that person usually lives at the premises, is living at the premises for the purpose of self-isolation or for medical emergency purposes; and</li> <li>▪ A person subject to self-isolation requirements will be discharged from self-isolation if they meet the criteria under existing Departmental requirements.<sup>182</sup></li> </ul>

<sup>177</sup> Victorian Government (2020) *Victoria Government Gazette*, no. s 169, p. 1; Victorian Government (2020) *Victoria Government Gazette*, no. s 194, p. 1; Victorian Government (2020) *Victoria Government Gazette*, no. s 190, p. 1; Victorian Government (2020) *Victoria Government Gazette*, no. s 199, p. 1; Victorian Government (2020) *Victoria Government Gazette*, no. s 206, p. 1.

<sup>178</sup> Victorian Government (2020) *Victoria Government Gazette*, no. s 253, p.1; Victorian Government (2020) *Victoria Government Gazette*, no. s 267, p. 18.

<sup>179</sup> Victorian Government (2020) *Victoria Government Gazette*, no. s 297, p. 25.

<sup>180</sup> Victorian Government (2020) *Victoria Government Gazette*, no. s 361, p. 33; Victorian Government (2020) *Victoria Government Gazette*, no. s 367, p. 32; Victorian Government (2020) *Victoria Government Gazette*, no. s 382, p. 14.

<sup>181</sup> Victorian Government (2020) *Victoria Government Gazette*, no. s 384, p. 23.

<sup>182</sup> Victorian Government (2020) *Victoria Government Gazette*, no. s 155, p. 1; Victorian Government (2020) *Victoria Government Gazette*, no. s 194, p. 23.

11-May	Expired and replaced by the <i>Diagnosed Persons and Close Contacts Directions</i> . This added a requirement that ‘persons living at the same premises as a diagnosed person, and close contacts of a diagnosed person, must self-quarantine’. <sup>183</sup> A new direction relaxed these requirements on 31 May, to allow persons required to self-isolate to visit a patient in a hospital, and to allow a self-quarantined person to receive household assistance, if needed. The <i>Diagnosed Persons and Close Contacts Direction (No. 3)</i> required, among other things, that ‘diagnosed persons notify the Department if a person begins residing with them while they are self-isolating’. <sup>184</sup> Replacing these were a fourth, fifth, sixth, and then seventh set of directions, the latter of which is still in force, requiring self-quarantine for diagnosed persons and persons who are living with or have been in close contact with a diagnosed person. <sup>185</sup>
<b>Stay at Home and Stay Safe Directions</b>	
30-Mar	Prohibited gathering directions were replaced by more stringent Stay at Home Directions. These Directions required everyone in Victoria to limit their interactions with others by ‘restricting the circumstances in which they may leave the premises where they ordinarily reside and replacing restrictions on gatherings’. <sup>186</sup> These Directions were modified to permit a person to ‘visit another person if they are in an intimate personal relationship’ and for childminding arrangements. <sup>187</sup>
31-May	Stay at Home Directions were replaced by Stay Safe Directions. This loosened restrictions, permitting gatherings of up to 20 people (subject to exceptions). <sup>188</sup> The focus shifted towards staying safe when leaving home, rather than requiring people to stay at home. These Directions were replaced on 21 June with the Stay Safe Directions (No. 2), with the ‘stay safe period’ to end on 12 July. These Directions tightened restrictions again, due to a ‘spike’ in COVID-19 cases. <sup>189</sup> Private gatherings were restricted to ‘no more than four other persons (who do not ordinarily reside at the premises)’ and public gatherings were limited to ‘9 other persons for a common purpose at a public space’. <sup>190</sup>
1-Jul	Stay at Home directions were reimposed on ten postcode areas, comprising nearly 40 suburbs in Melbourne’s inner north and west, following several days of escalating detected COVID-19 cases. Two further postcodes were added to this list at midnight on 4 July. These postcodes were designated ‘restricted areas’. Everyone who lives in a restricted area is required to stay home, with only four reasons to leave home: shopping for essentials, providing care giving, exercise, and work or study that cannot be done from home. For residents outside these areas, ‘common sense’, with physical distancing, handwashing and masks is strongly recommended. The latest Stay at Home directions made on 22 July are set to expire 16 August. <sup>191</sup>
<b>Public housing ‘hard lockdown’</b>	
4-Jul	Nine public housing estates in Flemington and North Melbourne were placed into a ‘hard lockdown’ (a media term), following the detection of 23 cases across 12 families living in some of these estates. <sup>192</sup> Some towers had been locked down on the ‘precautionary principle’ that transmission may have occurred between the buildings. <sup>193</sup> Residents were required to stay inside their homes under the ‘detention’ directives, unless granted permission to receive medical care, if reasonably necessary for physical and mental health, or on compassionate grounds. Non-residents were not permitted at these premises. The

<sup>183</sup> Victorian Government (2020) *Victoria Government Gazette*, no. s 231, p. 23.

<sup>184</sup> Victorian Government (2020) *Victoria Government Gazette*, no. s 297, p. 2.

<sup>185</sup> Victorian Government (2020) *Victoria Government Gazette*, no. s 361, p. 55.

<sup>186</sup> Victorian Government (2020) *Victoria Government Gazette*, no. s 169 p. 8.

<sup>187</sup> Victorian Government (2020) *Victoria Government Gazette*, no. s 177 p. 1.

<sup>188</sup> Victorian Government (2020) *Victoria Government Gazette*, no. s 267, p. 33.

<sup>189</sup> M. Davey (2020) ‘[Spike in Victoria coronavirus cases “certain” to result in “significant community transmission”](#)’, *The Guardian*, 23 June.

<sup>190</sup> Victorian Government (2020) *Victoria Government Gazette*, no. s 297, p. 19.

<sup>191</sup> Victorian Government (2020) *Victoria Government Gazette*, no. s 367, p. 1.

<sup>192</sup> Victorian Government (2020) *Victoria Government Gazette*, No. s. 434, 5 July, pp. 1–32; Premier of Victoria (2020) [Statement from the Premier](#), media release, 4 July; P. Russo (2020) ‘[Nine Melbourne tower blocks put into ‘hard lockdown’ – what does it mean, and will it work?](#)’ *The Conversation*, 5 July.

<sup>193</sup> M. Fowler and C. Booker (2020) ‘[Anger at hard lockdown for towers without confirmed virus cases](#)’, *The Age*, 5 July.

	directive was made on 4 July and revoked five days later. <sup>194</sup> Detention was enforced by 500 Victoria Police officers, stationed across every floor of the towers. <sup>195</sup>
<b>Stage 3: Metro Melbourne and Mitchell Shire lockdown</b>	
8-Jul	<p>After Victoria's second wave of COVID-19 cases, a Statement from the Premier on 7 July announced the Stage 3 'Stay at Home' restrictions across metropolitan Melbourne and Mitchell Shire.<sup>196</sup> At the beginning of his statement, the Premier lamented that '2020 has not been the year any of us wanted'.<sup>197</sup> Area Directions, read together with Stay at Home Directions, enforced six weeks of 'lockdown', with only four reasons to leave home (as above).<sup>198</sup> On 20 July, the Area Directions were extended, set to end on 16 August.<sup>199</sup></p> <p>Despite having significantly tightened restrictions under Stage 3, the rate of community transmission continued to rise throughout the month of July. On 31 July, Victoria confirmed 723 new cases and 13 deaths, Australia's highest daily totals since the start of the pandemic.<sup>200</sup></p>
<b>Mandatory masks</b>	
22-Jul	<p><i>Restricted Activity Directions (Restricted Areas) (No 3)</i> and <i>Stay at Home Directions (Restricted Areas) (No 4)</i> and <i>Stay Safe Directions (No 7)</i> were introduced. The new Stay at Home Directions and Stay Safe directions require that a person may only leave home if they 'wear a face mask at all times', unless an exception applies.<sup>201</sup> Where an employee is permitted to perform work at the employer's premises, the new Restricted Activity Directions require employers to 'take reasonable steps to ensure the employee wears a face covering at all times'.<sup>202</sup> All three directions expire on 16 August.</p>
<b>Stage 4: Metro Melbourne and Mitchell Shire lockdown</b>	
2-Aug	<p>At 6pm, Victoria entered a State of Disaster and moved to Stage 4 restrictions. In a statement, Premier Daniel Andrews announced that stronger rules were being put in place in order to 'limit the movement of people – and limit the spread of [the] virus across [the] city'.<sup>203</sup> Under Stage 4, new restrictions include:</p> <ul style="list-style-type: none"> <li>▪ a curfew from 8pm to 5am, with the only reason to leave home during these hours being work, medical care and caregiving;</li> <li>▪ Night network suspended, with public transport services reduced during curfew hours;</li> <li>▪ exercise limited to a maximum of one hour per day and no more than five kilometres from home;</li> <li>▪ study at TAFE and university must be done remotely, with schools returning to remote and flexible learning;</li> <li>▪ closure of early childhood services; and</li> <li>▪ no weddings in Melbourne.</li> </ul> <p>These restrictions will remain in place for at least six weeks, until Sunday 13 September.<sup>204</sup></p>
3-Aug	<p>A follow-up statement from the Premier on 3 August announced new restrictions for businesses and workers. As part of Stage 4, three lists have laid out changes to businesses and workers to limit people moving around the state for work:</p>

<sup>194</sup> Victorian Government (2020) *Victoria Government Gazette*, no. s 343; Victorian Government (2020) *Victoria Government Gazette*, no. s 350, p. 4.

<sup>195</sup> D. Estcourt and C. Lucas (2020) 'Thousands of public housing tenants under hard lockdown as COVID-19 spreads', *The Age*, 4 July.

<sup>196</sup> Premier of Victoria (2020) *Statement from the Premier*, media release, 7 July.

<sup>197</sup> *Ibid.*

<sup>198</sup> Victorian Government, *Victoria Government Gazette*, no. s 346, p. 1.

<sup>199</sup> Victorian Government, *Victoria Government Gazette*, no. s 361, p. 2.

<sup>200</sup> ABC News (2020) 'Victoria records 723 new coronavirus cases and 13 deaths in pandemic's deadliest day', *ABC News*, 31 July.

<sup>201</sup> Victorian Government (2020) *Victoria Government Gazette*, no. s 367, pp. 1–25.

<sup>202</sup> Victorian Government (2020) *Victoria Government Gazette*, no. s 200, p. 14.

<sup>203</sup> Premier of Victoria (2020) *Statement On Changes To Melbourne's Restrictions*, media release, 2 August.

<sup>204</sup> *ibid.*; Victorian Government (2020) *Victoria Government Gazette*, no. s 384, p. 61.

	<ul style="list-style-type: none"> <li>▪ The first list confirms businesses and workers that will continue to operate. Included are supermarkets, grocery stores, bottle shops, pharmacies, petrol stations, banks, newsagencies, post offices and frontline response workers.</li> <li>▪ The second list details businesses which are to cease operations by Wednesday 5 August at 11:59pm. Among these are retail, manufacturing and administration operations.</li> <li>▪ The third list outlines that food production, waste collection and supply chain logistics industries are permitted to operate, but under significantly different conditions.<sup>205</sup></li> </ul>
--	--

### *Penalties and enforcement*

Penalties for failing to comply with directions are set out under section 203 of the *Public Health and Wellbeing Act 2008*. Non-compliance may result in a fine of up to \$20,000 for persons and \$100,000 for bodies corporate.<sup>206</sup> The Premier made these penalties explicit when the first round of public gathering restrictions was announced.<sup>207</sup>

On 28 March 2020, further regulations were issued under the PHW Act for infringements of the emergency measures.<sup>208</sup> These offences included refusing or failing to comply with emergency directions (sections 200 and 203(1) of the Act), public health risk power directions (sections 190 and 193(1) of the Act) or a Chief Health Officer direction to provide information (section 188(2) of the Act); and hindering or obstructing an Authorised Officer (section 183 of the PHW Act).

The DHHS delegated enforcement of the PHW Act to Victoria Police, enabling police officers to issue on-the-spot infringement notices carrying a penalty of ten penalty units (\$1,652) for individuals and 60 penalty units (\$9,913) for bodies corporate. In its submission to the COVID-19 Senate Select Committee, dated 13 May 2020, the Victorian Government reported 43,829 completed COVID-19 police checks, with 2,894 fines and 833 warnings issued.<sup>209</sup>

Victoria Police have conducted several operations enforcing the directions:

- Operation Sentinel, to enforce staying at home, restricted activity and isolation directions as per the State of Emergency declaration, involving 1,200 police by July 2020.<sup>210</sup>
- Operation Nexus, to enforce health directions over the Easter long weekend.<sup>211</sup>
- Operation Ribbon, to respond to family violence.
- Operation Shielding, redeploying Protective Service Officers.
- Operation Benessere, implementing the lockdown of nine public housing towers from 4 July.<sup>212</sup>

Significantly, the Public Health and Wellbeing Regulations 2019 were amended on 22 July, to insert 'fail[ure] to comply with a requirement in relation to face covering' as an infringement offence. It prescribes a \$200 penalty for non-compliance.<sup>213</sup> In line with these regulations, the Premier announced

<sup>205</sup> Premier of Victoria (2020) [Statement from the Premier](#), media release, 3 August.

<sup>206</sup> Public Health and Wellbeing Act 2008 (Vic), ss 209–10.

<sup>207</sup> Premier of Victoria (2020) [More Restrictions Put In Place In The Fight Against COVID-19](#), media release, 18 March.

<sup>208</sup> *Public Health and Wellbeing Amendment (Infringements) Regulations 2020 (Regulations)*

<sup>209</sup> Victorian Government (2020) op. cit., p. 13.

<sup>210</sup> N. Wolfe (2020) ['Coronavirus Victoria: Hundreds more police added to "Operational Sentinel"'](#), *News.com.au*, 8 July.

<sup>211</sup> L. Neville, Minister for Police and Emergency Services (2020) [Police out in force to keep Victorians safe this Easter](#), media release, 9 April.

<sup>212</sup> Premier of Victoria (2020) [Statement from the Premier](#), media release, 4 July.

<sup>213</sup> [Public Health and Wellbeing Amendment \(Further Infringement Offences\) Regulations 2020](#).

on 20 July that ‘the Victorian Government has placed orders for 1.37 million reusable fabric masks from five Victorian manufacturers’.<sup>214</sup>

### Other legislation

For the purpose of supporting Victoria’s response to, and recovery from, COVID-19, the *COVID-19 Omnibus (Emergency Measures) Act 2020* has made temporary amendments to approximately 30 pieces of legislation. The Act, which includes ‘urgent measures to enact a number of policies across a range of portfolios’, came into operation on 25 April 2020.<sup>215</sup> The majority of these amendments will sunset within six months of being made. Key reforms across the Ministerial portfolios include:

**Table 5. Amendments made under the *COVID-19 Omnibus (Emergency Measures) Act 2020***

Affected portfolio	Amendment
<i>Justice and Community portfolio</i>	On 18 and 19 March 2020, the Deputy Chief Health Officer issued directions that people arriving in Victoria from overseas via aeroplane or ship, or by Australian cruise ship, must go into immediate compulsory quarantine for 14 days. <sup>216</sup> On 28 March, the Chief Health Officer issued a direction revoking the airport arrivals and cruise ship docking directions, recognising both had been superseded by the compulsory quarantine Direction and Detention notice issued by the Commonwealth Government. <sup>217</sup>
<i>Workplace Safety portfolio</i>	The Act amends legislation to give long-term injured workers who are unable to return to work or find employment an additional six months’ notice of termination to provide a longer transition period to return to work or find employment.
<i>Energy, Environment and Climate Change, Local Government and Planning portfolios</i>	The Act delays commencement of Victoria’s reforms to the environment protection framework to enable duty holders to focus on immediate challenges posed by the COVID-19 pandemic; permits local councils and libraries to operate more flexibly by having virtual council meetings; and amends the <i>Planning and Environment Act 1987</i> to enable requirements to make planning scheme amendments, planning permit applications and other documents physically available for inspection to be satisfied by displaying these documents on an internet site.
<i>Education and Training and Skills portfolio</i>	The Act amends the <i>Education and Training Reform Act 2006</i> to establish a temporary scheme to enable Victoria’s education system and its teachers to continue to deliver learning outcomes.
<i>Health portfolio</i>	The Act amends the <i>Safe Patient Care (Nurse to Patient and Midwife to Patient Ratios) Act 2015</i> to establish a new limited power for the Minister for Health to temporarily suspend the operation of the enforcement provisions of the Act, should it become impracticable for health services to meet the nurse-to-patient ratios
<i>Premier’s portfolio</i>	The Act amends the <i>Parliamentary Committees Act 2003</i> to enable members of committees established under that Act to attend meetings and vote remotely.

Source: Premier of Victoria (2020) ‘[Second reading speech: COVID-19 Omnibus \(Emergency Measures\)](#)’, *Debates*, Victoria, Legislative Assembly, 23 April, pp. 1197–1202.

### COVID-19 as a Victorian ‘state of disaster’

Accompanying metropolitan Melbourne’s move to ‘Stage Four’ restrictions and regional Victoria’s return to ‘Stage Three’ restrictions, on 2 August a ‘state of disaster’ was declared for the whole of Victoria under the *Emergency Management Act 1986* (Vic). This is only the second time the emergency powers under this Act have been invoked, following their use during the January 2020 bushfires. On the first occasion, the declaration was limited to specific areas that were in danger from the spread of

<sup>214</sup> Premier of Victoria (2020) [Face Coverings And Masks For Metro Schools](#), media release, 20 July.

<sup>215</sup> Premier of Victoria (2020) ‘[Second reading speech: COVID-19 Omnibus \(Emergency Measures\) Bill 2020](#)’, *Debates*, Victoria, Legislative Assembly, 23 April, p. 1197.

<sup>216</sup> Victorian Government (2020) *Victoria Government Gazette*, no. s 135, p. 1; Victorian Government (2020) *Victoria Government Gazette*, no. s 139, p. 1.

<sup>217</sup> Victorian Government (2020) *Victoria Government Gazette*, no. s 167, p. 1.



bushfires, and initially limited to seven days before later being extended.<sup>218</sup> In August, the state of disaster has been applied to the whole state for one month, the maximum period under the Act. A further declaration can be made to continue the state of disaster if necessary.<sup>219</sup>

The *Emergency Management Act 1986* allows to Premier of Victoria to make this declaration in consultation with the Minister for Police and the EMC. The declaration gives the Minister for Police responsibility for directing and co-ordinating the activities of all government agencies. The Minister's directions prevail over anything contrary to state laws. This includes the power to suspend the operation of part or the whole of any Victorian Act or legislative instrument.<sup>220</sup>

### *Using 'state of disaster' powers in COVID-19*

On announcing the 'state of disaster', Victorian Premier Daniel Andrews has said the declaration 'will give our police additional powers to make sure people are complying with public health directions'.<sup>221</sup> Chief Health Officer Brett Sutton likened the declaration to 'shock and awe' tactics, 'for people to genuinely understand that it's a super challenging phase we're in'.<sup>222</sup> These comments echo the 2009 Victorian Bushfires Royal Commission, which recommended the use of declaring a 'state of disaster' in emergencies so to 'provide symbolic recognition of the gravity of the situation'.<sup>223</sup>

### *Relationship with the public health 'state of emergency'*

Section 198 of the Public Health and Wellbeing Act provides that a declaration of a state of emergency 'does not derogate from or limit any provisions in relation to the declaration of an emergency under any other Act'.<sup>224</sup> According to constitutional law expert, Professor Anne Twomey, the likely intention of this provision is that 'the powers conferred on people in relation to both a state of emergency and a state of disaster should be exercised in a cooperative and co-ordinated manner to ensure a whole of government response to the emergency'.<sup>225</sup>

## 3. Tensions and issues

---

At the beginning of the millennium, the World Health Organization warned that 'in the twenty-first century, infectious diseases pose a more deadly threat to humankind than war'.<sup>226</sup> As we have seen, Australian and state governments have subsequently implemented a range of emergency legislation and management frameworks to prepare for these threats. In that time, Australian scholars and legal experts have shown increasing interest in a range of constitutional, human rights and administrative issues that such powers and frameworks may pose to Australia's federal system.<sup>227</sup> The emergency

---

<sup>218</sup> Emergency Management Victoria (2020) *State of disaster extended for 48 hours*, media release, 9 January.

<sup>219</sup> Emergency Management Act 1986 (Vic), s 23(6).

<sup>220</sup> *ibid*, s 23.

<sup>221</sup> Premier of Victoria (2020) *Statement On Changes To Melbourne's Restrictions*, *op. cit.*

<sup>222</sup> J. Ferguson (2020) 'Coronavirus: Freedom the first causality in an anxious city', *The Australian*, 3 August.

<sup>223</sup> Victorian Bushfires Royal Commission (2009) *Final Report. Vol 2*, Melbourne, Government Printer Commission, p. 86.

<sup>224</sup> Emergency Management Act 1986 (Vic), s 198(9).

<sup>225</sup> A. Twomey (2020) 'Explainer: what is a 'state of disaster' and what powers does it confer?', *The Conversation*, 2 August.

<sup>226</sup> Cited in P. Moore (2001) *Killer Germs: Rogue Diseases of the Twenty-First Century*, London, Carlton Books, p. 2.

<sup>227</sup> For example: G. Howse (2004) 'Managing emerging infectious diseases: Is a federal system an impediment to effective laws?', *Australia and New Zealand Health Policy*, 1; S. Guy and B. Hocking (2006) 'Times of Pestilence: Would a Bill of Rights Assist Australian Citizens Who Are Quarantined in the Event of an Avian Influenza (Bird Flu) Pandemic?', *Current Issues in Criminal Justice*, 17(3), pp. 451–467.

response to the COVID-19 pandemic, following on from the 2019–20 bushfire season, has brought many of these issues into sharper focus. The final part of this paper considers some of these issues in the context of Australia and Victoria’s emergency responses to COVID-19.

## 3.1 Constitutional matters

### Border closures

Closing state borders has been one of the most prominent measures adopted to limit the spread of COVID-19. All the states and territories, except Victoria, have imposed interstate border restrictions [see [Jurisdictional comparison](#)].<sup>228</sup> These measures echo one of the chief strategies used by state governments against the spread of Spanish Flu a century ago.<sup>229</sup> Now, as then, border closures have been subject to considerable discussion and negotiation between states and the Commonwealth Government.<sup>230</sup>

From late March, Western Australia announced border closures with exemptions for essential service workers and required 14-day self-isolation for interstate travellers, while South Australia established check points at border crossings.<sup>231</sup> Western Australia tightened its ban on 5 April, instructing airlines to prohibit non-West Australians without exemptions from boarding flights into the state.<sup>232</sup> By early July, all states and territories except Victoria, New South Wales and the ACT had closed their borders to residents of other jurisdictions, with varying degrees of severity. By early July, some states had reopened, or were planning to reopen their borders, except to those from designated ‘hot spots’. This referred mainly to Victoria or people who had visited Victoria after that state experienced a second spike in community transmission of COVID-19 from June.<sup>233</sup>

#### *The NSW-Victoria border*

Early in the pandemic, commentators believed it was highly unlikely New South Wales would close its border with Victoria, as it did in 1919. Unlike other state borders in Australia, the NSW–Victoria border is highly porous, with over 50 crossings of various sizes, which meant closing them would be a logistical challenge. The cities and towns on the border would be significantly impacted by any closures.<sup>234</sup> However, following a second spike in Victorian cases from late June, NSW temporarily closed its borders with Victoria on 8 July, including road closures on the NSW and Victoria border. Aircraft arriving from Victoria at NSW airports were being met by police and health staff and NSW residents

---

<sup>228</sup> RMIT ABC Fact Check Unit (2020) ‘[Is it illegal under the constitution for a state to close its borders to other Australians?](#)’ *ABC News*, 23 April.

<sup>229</sup> Huf and Mclean (2020) *op. cit.*; see also, S. Moloney and K. Moloney (2020) ‘[Border closures, identity and political tensions: how Australia’s past pandemics shape our COVID-19 response](#)’, *The Conversation*, 2 July.

<sup>230</sup> (2020) ‘[Prime Minister Scott Morrison to address state border closures and economic recovery at National Cabinet](#)’, *Perth Now*, 12 June; M. Grattan (2020) ‘[Coronavirus has made state borders a battle zone and premiers are manning the barricades](#)’, *ABC News*, 22 May; B. Doherty (2020) ‘[State leaders resist Morrison government push to reopen borders closed by coronavirus](#)’, *The Guardian*, 19 May; J. Norman (2020) ‘[States under pressure to reopen borders closed in a bid to contain coronavirus](#)’, *ABC News*, 18 May.

<sup>231</sup> (2020) ‘[Western Australia, South Australia to close border in response to coronavirus pandemic](#)’, *ABC News*, 22 March.

<sup>232</sup> E. Lachson and R. Trigger (2020) ‘[Coronavirus sees WA close its borders from midnight on Sunday to stop COVID-19 spread from eastern states](#)’, *ABC News*, 2 April.

<sup>233</sup> After the spike in coronavirus cases in Victoria in June 2020, Victoria has 79 Local Government Areas currently considered hotspots. Three other hotspots are located in NSW. See: Department of Health (2020) ‘[State quarantine requirements for interstate travel](#)’, Australian Government website. See also M. Collett (2020) ‘[Coronavirus restrictions: Where you can and can’t travel around Australia as borders reopen](#)’, *ABC News*, 2 July.

<sup>234</sup> B. Kontominas (2020) ‘[Why the NSW border won’t shut despite a spike in Victorian coronavirus cases](#)’, *ABC News Online*, 23 June.

returning home from Victoria were required to self-isolate for 14 days.<sup>235</sup> A system of permits and exemptions was implemented to assist communities living in border towns.<sup>236</sup> On 8 July, the ACT also implemented a travel ban on Victorians entering the ACT, with some exemptions.<sup>237</sup>

### *Challenging border closures*

Closing state borders raises significant constitutional issues. Section 92 of the Australian Constitution guarantees that ‘trade, commerce and intercourse among the states, whether by means of internal carriage or ocean navigation, shall be absolutely free’.<sup>238</sup> Former Foreign Minister, Alexander Downer and Senator Pauline Hanson, among others, questioned the constitutional validity of state border closures, and Minister for Home Affairs, the Hon. Peter Dutton, encouraged Queenslanders to challenge the constitutionality of the measure.<sup>239</sup>

In May and June 2020, several applications to challenge the border closures were filed: two by businessperson and former federal MP Clive Palmer, against both the WA and Queensland closures; and another by a group of Queensland tourism operators.<sup>240</sup> The two Queensland challenges were dropped in July.<sup>241</sup> Mr Palmer’s challenge of the WA closure began proceedings in the Federal Court on 27 July. Judge Darryl Rangiah told the parties the task was to determine whether the border closure was reasonably needed to contain the spread of coronavirus, and what the consequences of reopening it would be.<sup>242</sup>

The Commonwealth Government has consistently argued in favour of open borders.<sup>243</sup> Prior to the outbreak of new cases in Victoria in late June, states and territories faced pressure from the Commonwealth Government to ease border restrictions and promote interstate economic activity.<sup>244</sup> In June, the Attorney-General announced the Commonwealth Government would intervene and provide evidence and support of the Palmer challenge.<sup>245</sup> On 31 July, the Attorney-General stated it would be ‘highly unusual if the Commonwealth didn’t intervene, adding: ‘as we have said all along,

---

<sup>235</sup> NSW Government (2020) *Border closure to protect NSW*, media release, 6 July; NSW Government (2020) *NSW and Victorian border closures*, media release, 8 July.

<sup>236</sup> Minister for Regional Development (2020) *Supporting Our Victorian And NSW Border Communities*, media release, 24 July.

<sup>237</sup> ACT Government (2020) *Update on ACT/Victoria travel restrictions*, media release, 7 July.

<sup>238</sup> Australian Constitution s 92.

<sup>239</sup> RMIT ABC Fact Check Unit (2020) op. cit.; B. Gussen (2020) ‘South Australia will re-open its border to some state, but not others. Is that constitutional?’, *The Conversation*, 17 June; S. Trask (2020) ‘Pauline Hanson threatens to challenge state coronavirus border closures in the High Court’, *SBS News*, 21 May; M. McGowan (2020) ‘Peter Dutton encourages people to challenge Queensland’s Covid-19 border closures’, *The Guardian*, 22 May.

<sup>240</sup> B. Smee (2020) ‘Clive Palmer launches high court challenge to Queensland coronavirus border closure’, *The Guardian*, 28 May; C. Merritt (2020) *Coronavirus Australia: See you in court, border rebels tell Anastacia Palaszczuk*, *The Australian*, 2 June.

<sup>241</sup> P. Karp (2020) ‘Clive Palmer-backed court challenge to Queensland Covid-19 border closure dropped’, *The Guardian*, 23 July.

<sup>242</sup> H. McNeil (2020) ‘“Back off”: Clive Palmer’s Federal Court challenge to bring down WA’s border begins’, *The Age*, 27 July.

<sup>243</sup> M. Grattan (2020) ‘View from The Hill: Morrison government accepts Victorian closure but won’t budge on High Court border challenge’, *The Conversation*, 6 July.

<sup>244</sup> B. Doherty (2020) ‘State leaders resist Morrison government push to reopen borders closed by coronavirus’, *The Guardian*, 19 May; J. Norman (2020) ‘States under pressure to reopen borders closed in a bid to contain coronavirus’, *ABC News*, 18 May.

<sup>245</sup> (2020) ‘Coronavirus: Federal government to join High Court challenge of WA’s border closure’, *9News*, 14 June; A. Styles (2020) ‘“This nonsense has to stop”: McGowan calls on PM to stop supporting Palmer’s border fight’, *Sydney Morning Herald*, 6 July.

that we believe the WA Government's position is likely unconstitutional and the evidence put will likely be to that effect'.<sup>246</sup> On 2 August, the Prime Minister announced the Commonwealth Government would be withdrawing its support of Mr Palmer's challenge, given the 'changed state of the pandemic'.<sup>247</sup>

Early during the COVID-19 lockdowns, Professor Twomey expressed doubt that such challenges would be successful. Despite the 'absolute free' clause, Twomey argued that 'the High Court has accepted that a state law may impede the entry into the state of persons, animals or goods that are likely to injure citizens'.<sup>248</sup> So long as the restriction of movement between borders is appropriate and adapted to the purpose, Twomey said, such restrictions were likely to be valid; COVID-19 would likely qualify as an appropriate purpose.<sup>249</sup> However, when the number of coronavirus cases ultimately reduces, constitutional lawyer George Williams contended that the legality of closed borders may 'run thin'.<sup>250</sup>

## Biosecurity Act

The Biosecurity Act has been described by constitutional law experts as an attempt to 'shift the constitutional boundaries between the Commonwealth and States with respect to civil emergencies', pushing the division of labour between the Commonwealth and the states, and between legislatures and executives, 'to its limits'.<sup>251</sup> The Act does recognise the limits of the federal system, for example, limiting that a direction must not be given to an officer or employee of a State or Territory (and its agencies) 'unless the direction is in accordance with an agreement between the Commonwealth and State, Territory, or body'. Nevertheless, the Act is explicitly framed to 'ensure that [it] is given the widest possible operation consistent with Commonwealth constitutional legislative power'.<sup>252</sup>

Legal experts have identified at least two major issues with this expansion of federal activity into public health emergencies. First, it reflects a potential realignment of federal–state responsibilities. Second, there remain broader questions about the constitutional validity of the Act.

### *Rearranging responsibilities?*

Victorian barrister Stephanie Brenker has described Chapter Eight of the Act, where emergency powers are outlined, as representing 'an unprecedented expansion of power by the federal executive'.<sup>253</sup> This is because, first, the subject-matter of the Act 'invades into terrain traditionally managed by the states', and second, it contains so-called Henry VIII clauses, in which the Australian Parliament delegates power to the executive to make laws that override other statutes. Specifically, the determinations made under section 477 are not disallowable by Parliament and apply 'despite any provision of any other Australian law'.<sup>254</sup> Even without this provision, section 109 of the Australian Constitution ensures Commonwealth law prevails where there are inconsistencies with state law.<sup>255</sup>

---

<sup>246</sup> E. Borrello, E. Laschon and D. Weber (2020) 'Clive Palmer's WA border challenge backed by Attorney-General Christian Porter, document shows', *ABC News*, 31 July.

<sup>247</sup> J. Carmody (2020) 'Commonwealth withdraws from Clive Palmer border case, Prime Minister's letter to WA Premier reveals', *ABC News*, 2 August.

<sup>248</sup> RMIT ABC Fact Check Unit (2020) op. cit.

<sup>249</sup> A. Twomey (2020) 'States are shutting their borders to stop coronavirus. Is that actually allowed?' *The Conversation*, 22 March. See also: G. Williams (2020) 'Coronavirus: Queensland may be on a constitutional borderline', *The Australian*, 25 May.

<sup>250</sup> RMIT ABC Fact Check Unit (2020) op. cit.

<sup>251</sup> Lee et al. (2019) op. cit., p. 170

<sup>252</sup> Explanatory Memorandum, Biosecurity Bill 2014, p. 92.

<sup>253</sup> Brenker (2020) op. cit.

<sup>254</sup> Biosecurity Act 2015 (Cth) s 477 (5).

<sup>255</sup> *Australian Constitution* s 109.

The extraordinary range of powers conferred by Chapter Eight of the Act raises several major issues. First, the Act's capacity for enforcing discretionary measures beyond the scrutiny of the Commonwealth Parliament raises significant human rights issues, [discussed below](#). Second, the Act provides scope for the Commonwealth to impinge or override on matters previously dealt with by the states. Third, even without legislative overlap, emergency operations conducted under the Act may lead to confusion over responsibilities between state and federal agencies. In the context of COVID-19, the second issue has largely been avoided due to the cooperation of the National Cabinet. However, the third issue may have been a cause of the mismanagement of the Ruby Princess cruise ship ([discussed below](#)).

### *Is it valid?*

Longer-term questions persist over the constitutional validity of the powers conferred under the Biosecurity Act. To be valid, the Biosecurity Act must be supported by a head of power in the Australian Constitution.<sup>256</sup> It has generally been assumed the most likely source of this power is the quarantine power under section 51(ix) of the Constitution. If the law was to be challenged, the Court would be required to judge whether it operated consistently or was 'sufficiently connected' to the quarantine head of power. Although the issue was discussed in passing in the 1945 *Pharmaceutical Benefits Case*, the scope of the quarantine power has never been directly examined by the High Court.<sup>257</sup>

Scholars have speculated on at least two ways in which the Biosecurity Act might be justified if challenged in the High Court, other than the quarantine power.<sup>258</sup> One possibility would be under the external affairs power, from which the Commonwealth Government derives authority to legislate for the implementation of international treaties. Legal expert Brian Opeskin has argued international agreements addressing public health may provide a foundation for centralising public health emergencies as a federal issue, an avenue partially realised with the passing of the *National Health Security Act 2007* (Cth) to give effect to the WHO's International Health Regulations.<sup>259</sup> However, as Brenker notes, the Biosecurity Act includes measures not covered by the IHR, 'and so, in the absence of a new international agreement, would unlikely be supported by the external affairs power'.<sup>260</sup>

A second option might be to validate the Biosecurity Act under the so-called 'nationhood' power, which would significantly fortify the centralisation of public health emergency powers. Nationhood powers are implied from sections 51(xxxix) and 61 of the Constitution. Developed over a series of High Court cases since World War II—most recently in response to a challenge to the Rudd Government's stimulus package during the 2009 Global Financial Crisis—it recognises that the federal executive must have power to act on matters that are truly 'national' in order to protect its status as a national government.<sup>261</sup> The most recent treatment, in *Pape vs Commonwealth* (2009), declared nationhood

---

<sup>256</sup> The constitutional heads of power listed in section 24 are the quarantine power; external affairs power; trade and commerce power; fisheries power; aliens power; corporations power; territories and Commonwealth places power; postal power; sickness benefits power; and census and statistics power.

<sup>257</sup> For an exploration of the possible interpretations, see, C. Reynolds (2004) 'Quarantine in Times of Emergency: The Scope of S 51 (ix) of the Constitution', *Journal of Law and Medicine*, 12(2), pp. 166–77.

<sup>258</sup> Brenker also notes the possibility of defending the validity of the Biosecurity Act by drawing on prerogative powers, though deems this highly unlikely as it would require historical precedent exercised by the Crown as recognised in common law and applicable to Australia; Brenker (2020) op. cit.

<sup>259</sup> B. Opeskin (1998) 'The Architecture of Public Health Law Reform: Harmonisation of Law in a Federal System', *Melbourne University Law Review*, 22, pp. 342–43.

<sup>260</sup> Brenker (2020) op. cit.

<sup>261</sup> G. Appleby (2014) 'Explainer: Australia's war powers and the role of parliament', *The Conversation*, 2 September; P. Gerangelos (2012) 'The Executive Power of the Commonwealth of Australia: Section 61 of the Commonwealth Constitution, 'nationhood' and the Future of the Prerogative', *Oxford University Commonwealth Law Journal*, 12(1), pp. 97–131.



powers cannot be invoked to set aside the distribution of powers between the Commonwealth Government and the states, or to hurry federal programs, but they do provide an avenue to defend extraordinary measures.<sup>262</sup> Brenker argues that while it is possible for the Commonwealth to justify COVID-19 as a national crisis based on international declarations and expertise, there is little guidance from the High Court about how to determine whether a particular measure comes within the Commonwealth's nationhood power.<sup>263</sup>

Lee et al. note that any such 'attempt to extend emergency powers into intra-State emergencies, without the states' permission, would undermine the rationale for Australia's federalist system, by interfering with problems that state governments should be capable of solving'.<sup>264</sup> Such powers, they argue, would risk what they call the 'constitutional resilience'—those existing strategies (such as the National Health Security Agreement) designed to ensure special powers do not 'permanently distort or undermine the Australian constitutional structure and the division of powers and responsibilities to which that structure gives effect'.<sup>265</sup>

### Financing emergency responses

The Commonwealth Government has traditionally supported the states and territories in managing civil emergencies by providing logistical and financial assistance. The grants power under section 96 of the Constitution allows the Commonwealth Government to provide financial assistance to any state 'on such term and conditions as the Parliament thinks fit'.<sup>266</sup> Hypothetically, this power provides the Commonwealth Government with some capacity to intervene in areas outside its usual reach. For example, it might allocate funds to state-run hospitals on conditions of priorities and performance standards.<sup>267</sup> In the past, such manoeuvres have typically been subject to and largely safeguarded by agreements reached between the state and Commonwealth governments by COAG's ministerial councils.<sup>268</sup>

During COVID-19, the Commonwealth Government's offer in April 2020 to advance \$3 billion to independent schools across Australia was made contingent on committing to having at least half their students in the classroom by 1 June 2020. This offer was interpreted by Victorian Minister for Education, the Hon. James Merlino, as 'forcing' independent schools to undermine the state government's strategy.<sup>269</sup> Although the Commonwealth Government funds independent schools, all schools must be registered with the relevant state authority, meaning states have jurisdiction over schools' operations. Previous Commonwealth governments have used a similar tactic in offering grants to state schools, conditional on implementing various policies.<sup>270</sup>

---

<sup>262</sup> *Pape vs Commissioner of Taxation* (2009) 238 CLR 1; A. Twomey. (2010) 'Pushing the Boundaries of Executive Power - Pape, the Prerogative and Nationhood Powers', *Melbourne University Law Review*, (34)1, pp. 313–343.

<sup>263</sup> Brenker (2020) op. cit.

<sup>264</sup> Public Health (Emergency) Declaration 2020 (No 1) (ACT); Lee et al. (2019) op. cit., p. 204.

<sup>265</sup> *ibid*, p. 174.

<sup>266</sup> Australian Constitution, s 96.

<sup>267</sup> S. Scully (2009) *Does the Commonwealth have constitutional power to take over the administration of public hospitals*, Canberra, Australian Parliamentary Library.

<sup>268</sup> Constitution Education Fund (2020) 'Is cooperative federalism all it's cracked up to be?', CEFA website, 26 March; K. Buchanan (2015) 'Australia: legal responses to health emergencies', *Library of Congress*, online.

<sup>269</sup> (2020) 'Coronavirus funding offer for independent schools 'completely inappropriate'', *Victorian Government says*, *ABC News*, 29 April.

<sup>270</sup> M. Harvey (2020) 'If COVID-19 is a national emergency, can the federal government take control of schools?', *The Conversation*, 1 May.



## 3.2 Rights and privacy

### COVID-19 and Victoria's Charter of Human Rights

The exercise of emergency powers tends to raise questions regarding the possible infringement of human rights and civil liberties. In Victoria, these questions take on an added salience due to the presence of the *Charter of Human Rights and Responsibilities Act 2006* (Vic).<sup>271</sup> In Victoria, all new laws must be accompanied by a statement of compatibility which shows the laws are consistent with the Charter. The Charter requires that there be reasonable proportionality between the limitations imposed on individual rights or freedoms and the purpose which the limitation seeks to achieve. The Charter may be relied on in court proceedings to challenge laws, measures and their application.<sup>272</sup>

Expectedly, the public health measures adopted to combat the spread of COVID-19 have raised such questions.<sup>273</sup> Legal scholars Kylie Evans and Nicholas Petrie have identified several possible human rights implications of Victorian COVID-19 measures, given the existence of the Victorian Charter. They argue that, in theory:

- Stay at Home orders may impinge upon freedom of movement rights;
- fines enforced by police for breaching social distancing rules breach the right of equality if applied inconsistently or unjustifiably;
- instances of Victoria Police arresting and fining activists during the restriction period may have infringed upon rights to freedom of expression, peaceful assembly and association and taking part in public life;
- school closures may fail a child's right to education; and
- virtual hearings of criminal cases may impinge upon the right to a fair trial.<sup>274</sup>

### Reactions by human rights advocates

Victoria's responses to COVID-19 have generally not attracted criticism for contravening the Human Rights Charter, but have been considered as proportionate to the risks posed by COVID-19. Liberty Victoria, a leading civil liberties advocacy group, declared its support for the government measures, accepting 'extraordinary steps are required to meet an extraordinary crisis', even as it remained committed to 'defending human rights and civil liberties by monitoring the introduction and enforcement of measures during this time'.<sup>275</sup>

Some advocates have expressed concern that pandemic policing has a disproportionate impact on vulnerable communities or groups. Liberty Victoria and other civil liberties groups expressed concerns over police fines, especially in relation to protesters' rights and the erosion of tenants' rights under temporary changes to rental laws.<sup>276</sup> Justice advocates claimed police data showed little correlation

---

<sup>271</sup> The only other states to codify human rights are the ACT and Queensland in the *Human Rights Act 2004* (ACT) and *Human Rights Act 2019* (Qld). The Commonwealth also provides a unique model of rights protection under the *Human Rights (Parliamentary Scrutiny) Act 2011* (Cth).

<sup>272</sup> K. Evans and N. Petrie (2020) 'COVID-19 and the Australian Human Rights Acts', *Australian Public Law*, 6 May.

<sup>273</sup> M. Shimwell (2020) 'Compulsory isolation in the fight against coronavirus: a clash of human rights and public health' *The Conversation*, 3 March; I. Lane (2020) 'What Australia's 'extreme' new coronavirus laws and police powers mean for our civil liberties', *The New Daily*, 30 March.

<sup>274</sup> Evans and Petrie (2020) op. cit.

<sup>275</sup> Liberty Victoria (2020) 'COVID-19 and human rights', website, 3 March.

<sup>276</sup> Liberty Victoria (2020) *Refugee protest arrest and fines*, media release, 4 April; Liberty Victoria (2020) *Liberty Victoria concerned about consequences of omnibus bill for month-to-month residential tenancies*, media release, 29 April; (2020) 'Victorian police issue more than 400 fines for coronavirus breaches over Easter weekend', *ABC News*, 13 April.

between enforcement of the orders and the spread of COVID-19 in the state, with areas of high migrant populations or greater social housing heavily targeted, despite few cases.<sup>277</sup> Submissions made by human rights groups to the Senate Committee on COVID-19 focused concerns on protecting the health and safety of people in detention and other closed facilities, including immigration detention, rather than the operation of emergency orders.<sup>278</sup>

### Human rights and public housing ‘hard lockdowns’

One aspect of pandemic policing that has attracted scrutiny was the lockdown of nine public housing towers in Flemington and North Melbourne.<sup>279</sup> On 4 July, following an outbreak at these estates, the Victorian Government closed and contained the towers requiring the 3,000 residents to stay inside their homes, enforced onsite by police and Protective Services Officers.<sup>280</sup> Experts and advocates raised objections that the lockdown further stigmatised ‘vulnerable’ public housing residents and exposed vulnerable residents to risk.<sup>281</sup> Residents expressed concern about there being no prior warning and lack of time to prepare, describing the situation as ‘prison-like’ conditions.<sup>282</sup>

### Biosecurity Act and human rights

In contrast to expressions of support for the emergency powers under Victoria’s *Public Health and Wellbeing Act 2008*, the Commonwealth Government’s exercise of special powers under the Biosecurity Act has attracted wider scrutiny.<sup>283</sup> Prior to a state of biosecurity emergency being declared on 16 March, the Law Council of Australia warned the Act’s ‘extraordinary’ powers ‘must be approached with the utmost caution’, lamenting that authorised officers’ ‘exceptional powers’ to issue biosecurity control orders ‘do not have the types of safeguards and independent oversight protections afforded to our law enforcement and security agencies’ exercise of coercive powers’.<sup>284</sup>

While Australia does not possess a bill or charter of rights, the *Human Rights (Parliamentary Scrutiny) Act 2011* (Cth) requires all new bills and disallowable legislative instruments to be accompanied by a statement of compatibility addressing the rights and freedoms recognised in the international human rights treaties that Australia has ratified.<sup>285</sup> As non-disallowable instruments, determinations made

---

<sup>277</sup> M. McGowan, A. Ball and J. Taylor (2020) ‘Covid-19 lockdown: Victoria police data sparks fears disadvantaged unfairly targeted’, *The Guardian*, 6 June.

<sup>278</sup> Human Rights Law Centre (2020) Submission to the Senate Select Committee into COVID-19, *Inquiry into the Australian Government’s response to the COVID-19 pandemic*, Canberra, The Committee; A. Laschz and M. Hurley (2020) ‘Joint Submission: OPCAT, places of detention and COVID-19’, *Inquiry into the Australian Government’s response to the COVID-19 pandemic*, Canberra, The Committee.

<sup>279</sup> (2020) ‘“Ham-fisted” lockdown of nine Melbourne public housing towers, some without confirmed COVID-19 cases, criticised’ *SBS News*, 6 July.

<sup>280</sup> Premier of Victoria (2020) *Statement from the Premier*, media release, 4 July.

<sup>281</sup> D. Kelly, K. Shaw and L. Porter (2020) ‘Melbourne tower lockdowns unfairly target already vulnerable public housing residents’, *The Conversation*, 6 July; S. Carrasco, M. Faleh and N. Dangol (2020) ‘Our lives matter – Melbourne public housing residents talk about why COVID-19 hits them hard’, *The Conversation*, 24 July.

<sup>282</sup> M. McGowan et al. (2020) op. cit.; Carrasco et al. (2020) op. cit.; J. Blakkarly (2020) ‘Melbourne’s public housing tenants voice concerns about ‘prison-like’ lockdown conditions’, *SBS News*, 7 July; R. Varga (2020) ‘“We’re so isolated; it’s like a prison”’, *The Australian*, 6 July.

<sup>283</sup> For a general critique, see, D. Carter (2020) op. cit.

<sup>284</sup> Law Council of Australia (2020) *Law Council of Australia President, Pauline Wright, statement regarding biosecurity control orders*, media release, 3 March. See also: AMA and Law Council of Victoria (2020) ‘COVID-19: Rights and responsibilities under the Biosecurity Act’, Fact Sheet, AMA website.

<sup>285</sup> Human Rights (Parliamentary Scrutiny) Act 2011 (Cth).

under a biosecurity emergency do not require scrutiny by such statements.<sup>286</sup> Nor are they subject to the oversight of the Senate Scrutiny of Delegated Legislation Committee.<sup>287</sup>

The *Biosecurity Act 2015* and the *Quarantine Act 1908* have both long attracted scrutiny on these grounds. As with the old Quarantine Act, the powers granted under the Biosecurity Act to biosecurity officials (called quarantine officials under the Quarantine Act) to order the detention of individuals, the lack of involvement by a court in this process, and the Act's broad administrative discretion, all raise significant human rights concerns. As noted above, it also raises concerns as to whether such powers are in fact constitutionally valid, and whether the Act is supported by the Constitution's quarantine power. Legal scholar, Anthony Gray, has described the Biosecurity Act as a 'vast improvement' on its predecessor (the Quarantine Act), showing 'greater sensitivity towards the human rights of those affected' by allowing for internal review of decisions. However, he remains concerned 'with a lack of judicial involvement in the decision to detain an individual, and the fact that many individuals subject to a control order may not understand their right to refuse to consent to it'.<sup>288</sup>

### Privacy and the COVIDSafe app

The Commonwealth Government's COVIDSafe tracing app has attracted particular scrutiny as potentially infringing individuals' rights.<sup>289</sup> When first announced under a biosecurity emergency directive in April 2020, multiple Australian human rights agencies and legal experts called for greater transparency on how the app would be used.<sup>290</sup> Media reports flagged the tracing app risked 'illegal and inappropriate use of data or surveillance' and created 'a honey pot for hacking'.<sup>291</sup> Experts described the app, the accompanying Determination under the Biosecurity Act to govern its operation, and the Privacy Impact Assessment as an 'experiment in creating public trust'.<sup>292</sup>

On 15 May 2020, regulations for the app were enshrined in the *Privacy Amendment (Public Health Contact Information) Act 2020* (Cth), which amended the *Privacy Act 1988* (Cth). Before the Bill was assented to, submissions from the UNSW Australian Human Rights Institute recommended changes to improve the Bill's human rights compliance, limit intrusiveness and increase oversight.<sup>293</sup> Amnesty International and the Australian Human Rights Commission also expressed concern that the proposed legislation did not provide for a mandatory termination date for all data collected by the app.<sup>294</sup>

---

<sup>286</sup> *ibid.*, s 9(1).

<sup>287</sup> A. Edgar (2020) *op. cit.*; see also: Parliament of Australia (2020) [Senate committee to continue to scrutinise delegated legislation, including COVID-19 related legislation](#), media release, 1 April.

<sup>288</sup> A. Gray (2015) 'The Australian quarantine and biosecurity legislation: Constitutionality and critique', *Journal of Law and Medicine*, 22, pp. 788–810.

<sup>289</sup> This is a global trend. See: Human Rights Watch (2020) [Covid-19 Apps Pose Serious Human Rights Risks](#), media release, 13 May.

<sup>290</sup> Human Rights Law Centre (2020) [Greater transparency needed around Federal Government's new COVID-19 phone app](#), media release, 8 April; K. Leins, S. Coghlan and M. Cheong (2020) 'Do we really need a tracking app and can we trust it?', *Legal Affairs*, 24 April.

<sup>291</sup> See, for example, D. Crowe (2020) 'Privacy advocates raise new concerns with COVIDSafe app', *The Sydney Morning Herald*, 11 May; L. Seebeck (2020) 'App is no silver bullet for virus, yet a honey pot for the malign', *Australian Financial Review*, 29 April.

<sup>292</sup> G. Greenleaf and K. Kempt (2020) 'Australia's 'COVIDSafe App': An Experiment in Surveillance, Trust and Law', *University of New South Wales Law Research Series*, 30 April, pp. 1–17.

<sup>293</sup> Australian Human Rights Institute (2020) 'Submission To The Parliamentary Joint Committee On Human Rights', *Parliamentary Joint Committee on Human Rights*, Canberra, The Committee.

<sup>294</sup> Amnesty International Australia (2020) 'Email Minister Roberts: Make sure the COVID-19 app respects human rights', website; Australian Human Rights Commission (2020) [Commission position on the draft 'COVIDSafe App' Bill](#), media release, 8 May.

The Commonwealth Parliamentary Joint Committee on Human Rights, which assesses all Commonwealth bills for compatibility with human rights and has continued to sit remotely through the pandemic, submitted two scrutiny reports identifying a number of measures that would further strengthen the ‘stringent privacy protections’ in the COVIDSafe app. The Bill was passed without any amendments before either of these scrutiny reports were tabled. Under the *Human Rights Parliamentary Scrutiny Act 2011* (Cth), there is no impediment to legislation being passed before the Committee reports, and no requirement that the Committee’s recommendations be implemented.

Despite these criticisms, technology law expert, Gordon Hughes, found the amendments made to the Privacy Act sufficiently protect the rights of individuals using the app in line with Australia’s commitment to human rights charters.<sup>295</sup> According to Hughes, these safeguards include:

- a clear explanation of how contract tracing will be used and a clear statement of limited purpose for which information is collected;
- that coercion of the public or employees to download the app is not permitted;
- data storage will be secure, with offshoring of data storage prohibited;
- contact data will not be retained for more than 21 days;
- oversight of the laws by the Office of the Australian Information Commissioner;
- opportunities for individuals affected by a breach to seek a remedy; and
- clarification that State and Territory health authorities are captured by data use restrictions.

### 3.3 Emergency administration: centralising tendencies?

Australia’s emergency management arrangements have been described by scholars as multi-strand and multi-level, incorporating international, national and state-level agreements and frameworks. This complexity, scholars argue, present strengths and weaknesses, enabling flexible and targeted responses to crises but exposing dangers of confused messaging and responsibilities and tension between jurisdictions.<sup>296</sup>

These arrangements have been significantly tested during the response to COVID-19, resulting in both administrative innovations that reflect the potential centralisation of emergency responses in Australia, and challenges over federal–state emergency responsibilities.

#### National Cabinet and the abolition of COAG

A major administrative change wrought by COVID-19 is the formation of a ‘National Cabinet’ and the subsequent decision to abolish COAG and replace it with the National Federation Reform Council (NFRC). The new National Cabinet, comprising the Prime Minister, state premiers and territory chief ministers, is to be made permanent as the chief committee of the NFRC. The existing Council on Federal Financial Relations (CFFR), consisting of Federal and state treasurers, will now report to the National Cabinet, as will a series of existing taskforces, including those working on domestic violence and Indigenous affairs. The NFRC will meet in person once a year—comprising the National Cabinet, the CFFR, and the Australian Local Government Association—to focus on priority national issues.<sup>297</sup> A series of ‘national cabinet subcommittees’, drawn from the states, territories and Commonwealth, will be

---

<sup>295</sup> G. Hughes (2020) op. cit.; University of Sydney (2020) ‘Experts examine the COVID-19 tracing app’, *The University of Sydney*, 28 April.

<sup>296</sup> B. Bennett et al. (2012) op. cit., p. 3; see also: T. Carney, R. Bailey and B. Bennett (2012) ‘Pandemic planning as risk management: How fared the Australian federation?’, *Journal of Law and Medicine*, 19, pp. 550–568.

<sup>297</sup> Department of Prime Minister and Cabinet (2020) *COAG becomes National Cabinet*, media release, 2 June; Prime Minister of Australia (2020) *Press conference*, transcript, 12 June.

established to drive reform in seven subject areas: rural and regional Australia; skills training; energy; housing; transport and infrastructure; population and migration; and health (see Figure 6).<sup>298</sup>

**Figure 6. Planned new National Federation Council reforms**

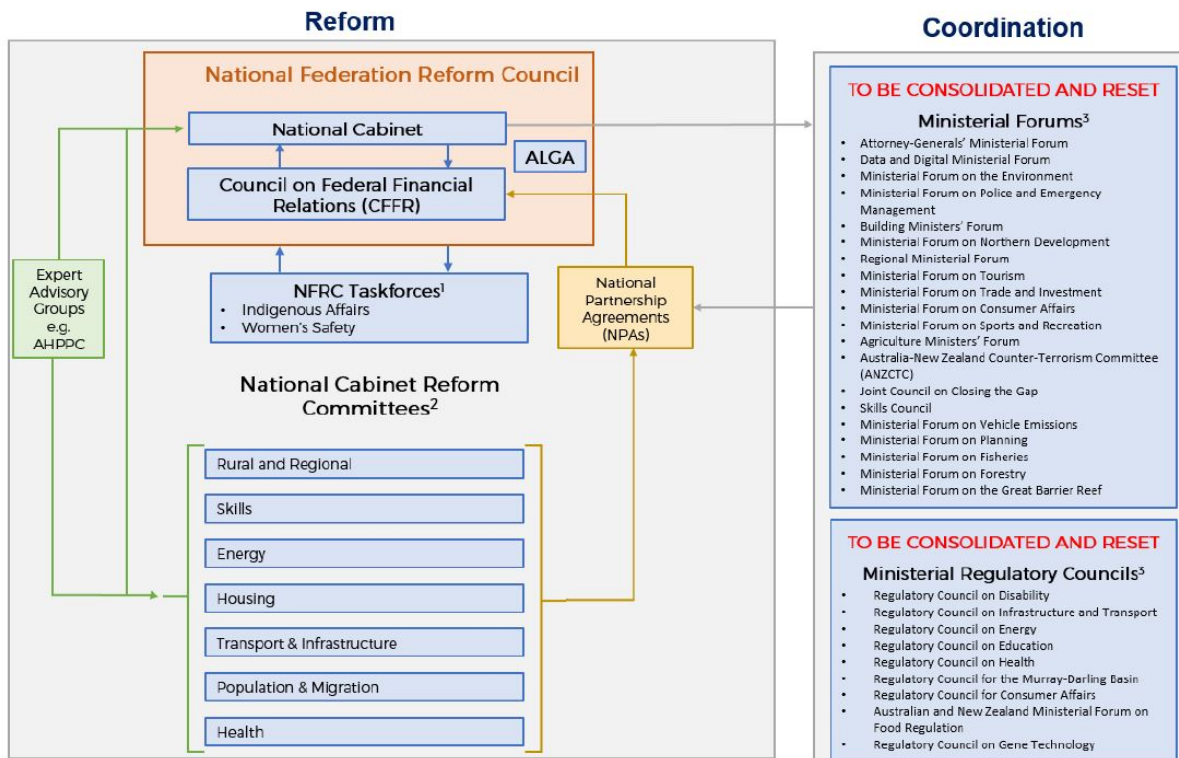

Source: M. McInerney (2020) 'What does killing off COAG mean for health, climate change, transparency and much more?', *Croakey*, 1 June.

### Responses to the National Cabinet

There has been a mixed reaction to this decision. Commentators have identified it as an opportunity to refocus the agenda of federal governance, but also note the risk of replicating the bureaucratic structures of COAG.<sup>299</sup> Calling the meeting a 'cabinet' has been identified as possibly hindering properly intergovernmental deliberation.<sup>300</sup> Relatedly, Professor Twomey, warns that constituting the National Cabinet as a 'cabinet office policy committee' of the Commonwealth cabinet, enables the federal cabinet to alter its decisions and confers the Prime Minister, as chair, with overriding authority, undermining 'the effectiveness of the national cabinet as a council of equals'.<sup>301</sup> Some health experts have expressed concern this change will enable the Commonwealth Government to set the agenda of health emergency priorities and responses, possibly diverting attention from climate change and the social determinants of health, such as poverty and food security.<sup>302</sup> The Australian Medical Association has supported the decision.<sup>303</sup>

<sup>298</sup> K. Lawson (2020) 'COAG abolished, national cabinet here to stay', *Canberra Times*, 29 May.

<sup>299</sup> L. Russell (2020) 'COAG's out. It's a fresh chance to put health issues on the agenda, but there are risks', *The Conversation*, 10 June.

<sup>300</sup> C. Saunders (2020) 'The National Cabinet has worked. Can it last?', *Pursuit*, 11 June.

<sup>301</sup> A. Twomey (2020) 'We should bake in improvements to our federation', *The Australian*, 6 July.

<sup>302</sup> M. McInerney (2020) 'What does killing off COAG mean for health, climate change, transparency and much more?' *Croakey Health Media*, 1 June.

<sup>303</sup> Australian Medical Association (2020) *Smart strategic move by the Government to replace COAG with the National Cabinet*, media release, 30 May.



## Other centralising models

In a substantial review of Australia's COVID-19 response, the Grattan Institute applauded the National Cabinet's cooperation and deference to experts, yet also argued that 'a grand realignment of responsibilities of the Commonwealth and the states', necessary for effective emergency responses, has 'patently has not been achieved'.<sup>304</sup> To achieve such realignment, the Institute advocates 'better on-the-ground coordination' by creating primary care agreements between the Commonwealth Government and each state, as well as making tripartite agreements with every Primary Health Network around Australia.<sup>305</sup>

Australian Medical Association President, Dr Tony Bartone, said the hotel quarantine breaches in Melbourne ([see below](#)) demonstrated the need for an independent national centre for disease control that would provide a uniform, acknowledged source of direction. Dr Bartone told the Senate Select Committee on COVID-19 that a national centre comprising a body of medical experts independent of political influence should be placed in charge of responding to pandemics.<sup>306</sup>

## Challenging state and federal responsibilities

### The Ruby Princess inquiry

State and federal emergency responsibilities have been challenged at various points during the pandemic response. An early issue was the management of the Ruby Princess cruise ship, when 2,700 passengers freely disembarked in Sydney on 19 March 2020, despite some showing COVID-19 symptoms.<sup>307</sup> In late April, it was reported that the cruise ship was Australia's largest single source of infection.<sup>308</sup> The incident has been the subject of three separate inquiries, including a NSW Special Commission of Inquiry, a NSW Police investigation and a coronial inquiry, which is contingent on the findings of a police investigation.<sup>309</sup> The issue has also been the subject of questioning in the federal Senate Select Committee on COVID-19.<sup>310</sup>

The NSW Special Commission of Inquiry focused on the communication, decisions and actions between multiple federal and state agencies that were involved in managing the cruise ship. These agencies included Australian Border Force, the federal Department of Agriculture, Water and the Environment, NSW Health, NSW Police, NSW Ambulance and the Port Authority of NSW.<sup>311</sup> Legal experts have commented that the central issue in relation to the Ruby Princess was 'uncertainty as to who has jurisdiction' due to 'overlapping responsibilities at the border'.<sup>312</sup> Jacinta Carroll, from the National Security College, observed that COVID-19 had generally tested Australia's border security

---

<sup>304</sup> S. Duckett (2020) *Coming out of COVID-19 lockdown: the next steps for Australian health care*, Melbourne, Grattan Institute, pp. 65–66.

<sup>305</sup> *ibid.*

<sup>306</sup> D. McCauley (2020) 'Melbourne quarantine breach sparks calls for independent medical body', *The Age*, 25 June.

<sup>307</sup> A. Patrick (2020) 'The 'super spreader' events behind Australia's epidemic', *Australian Financial Review*, 27 March.

<sup>308</sup> P. Cockburn (2020) 'How the coronavirus pandemic would look in Australia if Ruby Princess had never docked', *ABC News*, 23 April.

<sup>309</sup> NSW Government (2020) *Special commission of inquiry into Ruby Princess*, media release, 15 April; Y. Bashan (2020) 'Coronavirus: NSW Police probe Ruby Princess health report', *The Australian*, 16 April; J. Kidd (2020) 'Police in Ruby Princess coronavirus probe to question more than 5,500 passengers as global cases rise', *ABC News*, 17 April.

<sup>310</sup> For example: (2020) 'Chief Medical Officer Brendan Murphy fronts Senate committee on Australia's coronavirus response', *ABC News*, 23 April.

<sup>311</sup> Special Commission of Inquiry into the Ruby Princess (2020) 'Terms of reference', website.

<sup>312</sup> A. Dale (2020) 'All out to sea', *Law Society Journal Online*, 4 May.



arrangements. ‘The inability of these three agencies [Border Force, Biosecurity Australia and NSW Health] to coordinate effectively at the time’ of the Ruby Princess docking, ‘showed a gap in existing arrangements’.<sup>313</sup>

### Melbourne quarantine hotels

Quarantine breaches also occurred in Melbourne’s quarantine hotels in May 2020. From late March, state and territory governments had quarantined passengers returning from international travels in hotels for 14 days.<sup>314</sup> States administered and paid for hotel quarantine and were assisted by the ADF and Australia Border Force. Legal power for enforcing quarantine protocols rested with state officials.<sup>315</sup>

From late May, the infection of security guards at two Victorian quarantine hotels, as well as breaches by quarantined return passengers, contributed to a new wave of community transmission.<sup>316</sup> The outbreak drew media attention to the Victorian Government’s management of hotel quarantine using contracted private security firms, which was contrasted with NSW hotel quarantine where state police and defence forces were heavily involved alongside private security.<sup>317</sup> Media also reported that security contractors were hastily recruited without proper training or equipment.<sup>318</sup> Industrial relations experts said the outbreak reflected more general and long-term issues over non-compliance with minimum standards in the private security industry.<sup>319</sup>

Following the outbreak, Victoria requested further ADF personnel to assist with the pandemic response, including hotel quarantine and testing. In March, 28 ADF personnel had been sent to Victoria to assist with the pandemic.<sup>320</sup> Around 350 ADF members were deployed to the state in June and a further 1,000 in July.<sup>321</sup>

On 2 July, a judicial inquiry into the hotel quarantine program was established, headed by the Hon. Jennifer Coate. The inquiry is due to report by 25 September 2020. The inquiry will examine the communications, decisions and actions between government agencies, hotel operators and private contractors.<sup>322</sup> The Victorian Government is also conducting a separate Review of Victoria’s Private Security Industry. The review began before COVID-19 and is due to report in December 2020.<sup>323</sup>

---

<sup>313</sup> J. Carroll (2020) ‘Coronavirus has seriously tested our border security’, *The Conversation*, 30 March.

<sup>314</sup> Premier of Victoria (2020) *Enforced Quarantine For Returned Travellers To Combat Coronavirus*, media release, 27 March.

<sup>315</sup> Prime Minister of Australia (2020) *Update on Coronavirus measures*, media release, 27 March; M. Grattan (2020) ‘Hotel quarantine for returning Aussies and ‘hibernation’ assistance for businesses’, *The Conversation*, 27 March.

<sup>316</sup> S. Ilanbey (2020) ‘Sutton says resuming office work from July “not out the question”’, 28 May; L. Thorne (2020) ‘Victoria’s coronavirus quarantine program to get a “reset” after breaches’, *ABC News*, 1 July.

<sup>317</sup> B. Schneiders (2020) ‘How hotel quarantine let COVID-19 out of the bag in Victoria’, *The Age*, 3 July; R. Baxendale (2020) ‘Tender waived for security Victoria’s quarantine hotels’, *The Australian*, 4 July.

<sup>318</sup> G. Tobin and A. McDonald (2020) ‘Coronavirus quarantine guards in Melbourne hotels were recruited via WhatsApp, then “told to bring their own masks”’, *ABC News*, 22 July.

<sup>319</sup> S. Kaine and E. Josserand (2020) ‘Melbourne’s hotel quarantine bungle is disappointing but not surprising. It was overseen by a flawed security industry’, *The Conversation*, 8 July.

<sup>320</sup> D. McCauley, R. Harris and S. Ilanbey (2020) ‘Military deployed to Melbourne’s quarantine hotels’, *Sydney Morning Herald*, 25 June.

<sup>321</sup> Premier of Victoria (2020) *More Australian Defence Force Personnel To Join Victoria’s Coronavirus Response*, media release, 14 July; (2020) ‘1,000 ADF personnel deployed to help coronavirus response in Victoria’, *ABC News*, 13 July.

<sup>322</sup> Premier of Victoria (2020) *Judicial inquiry in hotel quarantine program*, media release, 2 July.

<sup>323</sup> Engage Victoria (2020) ‘Review of Victoria’s Private Security Industry’, website.

## Victorian aged care

Along with meat processing, call centres and distribution centres, aged care facilities have been at the centre of several major outbreaks in Australia. The most notable have included Newmarch House in New South Wales in April and multiple outbreaks in Victorian facilities in June and July. By late July, 683 of the 4,500 active cases in Australia were linked to aged care facilities, including at least 500 in Victoria.<sup>324</sup> The high incidence in aged care facilities is thought to be due to several circumstances. Low-paid and casual staff often work across multiple facilities and are in close contact with residents vulnerable to COVID-19, significantly increasing the chance of transmission.<sup>325</sup>

Both federal and state governments are responsible for sections of the aged care system. Private providers are regulated and inspected by Commonwealth law and agencies, and eligible for some federal funding. Most nursing homes in Australia are privately owned, by both for-profit and not-for-profit providers. States also run a much smaller number of public aged care homes. Out of about 50,000 beds in Victoria, 5,400 are in the public system, largely in regional areas. The federal regulator still accredits and oversees these facilities.<sup>326</sup>

Given that responsibility for the health sector and hospitals rests with the state, the care and management of aged care residents during COVID-19 has proven a point of tension in coordinating the federal–state emergency response to the pandemic.<sup>327</sup> Several agreements are in place outlining federal and state responsibilities. The *Australian Health Sector Emergency response Plan for Novel Coronavirus* outlines the roles of federal, state and territory health departments and non-government agencies, including quality standards and agreements that state and territories will establish systems to protect people in aged care.<sup>328</sup> States and territories have issued aged care plans or directions for COVID-19, including Victoria's *Coronavirus (COVID-19) Plan for the Victorian Aged Care Sector*, which advises on the preparedness, prevention and case management of COVID-19 outbreaks.<sup>329</sup>

In response to the Victorian aged care outbreaks, on 27 July the federal and Victorian governments jointly established the Victorian Aged Care Response Centre to coordinate resources, located at Victoria's State Control Centre in Melbourne.<sup>330</sup> The Centre has moved to providing personnel, including AUSMAT and interstate nurses, restricting staff to working at a single site, distributing personal protective equipment and expanding testing facilities.<sup>331</sup> This response builds on advice, funding and processes, such as limiting visitor numbers, implemented earlier in the pandemic.<sup>332</sup> As with private security contractors, experts observed many of the issues related to COVID-19 outbreaks

---

<sup>324</sup> G. Hitch and J. Hayne (2020) 'What's being done nationally to prevent coronavirus outbreaks in aged care homes?', *ABC News*, 28 July.

<sup>325</sup> B. Judd and C. Taylor (2020) 'Melbourne aged care is facing a coronavirus catastrophe. This is how it happened', *ABC News*, 29 July.

<sup>326</sup> M. Bachelard (2020) 'Who is responsible for aged care homes?', *The Age*, 30 July.

<sup>327</sup> M. Grattan (2020) 'View from The Hill: Aged care crisis reflects poor preparation and a broken system', *The Conversation*, 28 July; D. Crowe (2020) 'Blame game won't help find a fix for the aged care corona crisis', *Sydney Morning Herald*, 28 July.

<sup>328</sup> Department of Health (2020) *Australian Health Sector Emergency response Plan for Novel Coronavirus*, Canberra, Commonwealth of Australia; A. Grove (2020) *COVID-19 and aged care: a quick guide*, Canberra, Australian Parliamentary Library.

<sup>329</sup> DHHS (2020) *(COVID-19) Plan for the Victorian Aged Care Sector*, Melbourne, Victorian Government. This document is adapted from the Communicable Diseases Network Australia (CDNA) national guidelines: Coronavirus Disease 2019 (COVID-19) Outbreaks in Residential Care Facilities, and the Commonwealth Infection Control Expert Group: COVID-19 Infection Prevention and Control for Residential Care Facilities.

<sup>330</sup> Minister for Aged Care and Senior Australians (2020) *Victorian Aged Care Response Centre*, media release, 27 July.

<sup>331</sup> *ibid.*; Hitch and Hayne (2020) *op. cit.*

<sup>332</sup> For an overview of earlier responses, see: Grove (2020) *op. cit.*

in aged care facilities stem from longer-term issues and staff shortages in aged care across Australia, as highlighted in the ongoing Royal Commission into Aged Care Quality and Safety.<sup>333</sup>

A major issue confronting federal–state cooperation is moving infected or at-risk aged care residents into hospitals. State governments control the administration of hospitals during public health emergencies. In July, it was reported that the DHHS had denied some aged care homes transferring residents, diagnosed with the virus, to hospitals.<sup>334</sup> The DHHS reserves this right, noting that according to Victoria’s COVID-19 Plan for the Victorian Aged Care Sector, residents are to be transferred on a case-by-case basis, and ‘cases should not be transferred unless clinically required’.<sup>335</sup>

Transfer policies vary between states. Transfer procedures require explicit state government intervention or guidance as hospitals are a state responsibility. Early in the COVID-19 crisis, South Australia was the only state with an explicit policy to immediately transfer all COVID-positive residents to hospital.<sup>336</sup> On 25 June, following the Newmarch House outbreaks and in consultation with the Commonwealth Department of Health, New South Wales Health released guidelines for the transfer of infected residents to hospitals.<sup>337</sup> On 10 July, it agreed to a joint protocol with the Australian Department of Health on managing residential aged care outbreaks.<sup>338</sup>

As at 2 August July, the Victorian Government remained committed to its case-by-case COVID-19 Aged Care Sector plan. However, it (re)suspended non-urgent elective surgery across public and private hospitals in metropolitan Melbourne to increase capacity for potential aged care transfers.<sup>339</sup> The sector’s peak bodies, including Aged & Community Services Australia and Leading Age Services Australia, have called for a uniform national policy on transferring aged care residents infected with COVID-19 to hospitals.<sup>340</sup> Both endorsed the model set by South Australia.<sup>341</sup>

---

<sup>333</sup> Royal Commission into Aged Care Quality and Safety (2019) *Aged Care in Australia: A Shocking Tale of Neglect*, media release, 31 October; Royal Commission into Aged Care Quality and Safety (2019) *Interim Report: Neglect*, 3 Volumes, Canberra, Commonwealth of Australia; R. Morton (2020) ‘Forgotten lives: Covid-19 outbreaks in aged care’, *The Saturday Paper*, 311, July 25–31.

<sup>334</sup> J. Topsfield and L. Mannix (2020) ‘Aged care home had request to transfer virus cases to hospital denied’, *The Age*, 16 July.

<sup>335</sup> *ibid*; DHHS (2020) *(COVID-19) Plan for the Victorian Aged Care Sector*, op. cit., p. 26.

<sup>336</sup> Department for Health and Wellbeing (2020) *Management of COVID-19 in residential aged care*, fact sheet, Adelaide, South Australian Government; (2020) ‘Stand-off between States over national policy on transferring COVID-19 aged care residents to hospital leaves providers hanging’, *The Weekly Source*, 1 July.

<sup>337</sup> NSW Health (2020) *Guiding principles for safe and efficient admissions into Residential Aged Care Facilities and transfers to hospital during the COVID-19 pandemic*, Sydney, NSW Government.

<sup>338</sup> Department of Health (2020) *Commonwealth and NSW protocol to help manage a COVID-19 outbreak in a residential aged care facility in NSW*, Canberra, Commonwealth Government.

<sup>339</sup> Premier of Victoria (2020) *Working Together To Protect Our Aged Care Residents*, media release, 28 July.

<sup>340</sup> ACSA (2020) *Hospitalisation of aged care residents should happen before major outbreaks*, media release, 28 July; LASA (2020) *Aged care facilities are not hospitals*, media release, 6 March.

<sup>341</sup> LASA (2020) *Call for health system coordination to protect older Australians*, media release, 23 June; ACSA (2020) *Aged care COVID-19 outbreak response must not discriminate or ration hospital care*, media release, 22 June.

## 4. Other Jurisdictions

Across Australia, a wide array of actions and directions have been taken by the different states and territories in response to the pandemic. To further contextualise what has been implemented in Victoria and provide a point of comparison, this section briefly outlines what has been administered under different jurisdictions. It does not intend to provide a comprehensive overview; rather, it highlights the key responses as they diverge from or are enacted similarly to Victoria. As above, the focus will be on the use of powers conferred under the states and territories' respective Public Health Acts.

**Table 6. Comparison of emergency legislation, border controls and penalties in Australian states and territories during COVID-19**

	Public Health Emergency declared (date)	Power and authority to issue directions, requirements or actions	Subsequent legislation	Interstate border control	Penalties for failure to comply with directions
Qld	29 January 2020	Chief Health Officer, <i>Public Health Act 2005</i> (Qld)	<i>COVID-19 Emergency Response Act 2020</i> (Qld)  <i>Public Health and Other Legislation (Public Health Emergency Amendment) Act 2020</i> (Qld)	In the latest Border restrictions <a href="#">Direction on 10 July</a> , any person who has been in a declared COVID-19 hotspot (including Victoria) within the last 14 days is not permitted to enter Queensland.  Any person travelling from NSW, Western Australia, South Australia, Tasmania, the ACT and the NT may enter Queensland subject to completing and signing a border declaration and undertaking to present for a COVID-19 test if they develop symptoms.	<i>Public Health Act 2005</i> (Qld) s 362D, maximum penalty of 100 penalty units, being \$13,345.00 for individuals, or \$66,725.00 for a body corporate.
ACT	16 March 2020	Minister for Health and ACT Chief Health Officer, <i>Public Health Act 1997</i> (ACT)	<i>COVID-19 Emergency Response Act 2020</i> (ACT)	On 8 July, the <a href="#">Directions</a> stated that anyone (other than ACT residents) travelling to the ACT from Victoria will be denied entry to the ACT unless they are granted an exemption by ACT health.  Per Directions made on <a href="#">20 July</a> , anyone who has visited specific NSW venues on specific dates is required to self-quarantine for 14 days from the date they were there, even if they do not have any symptoms.	<i>Public Health Act 1997</i> (ACT) s 120, maximum penalties of \$8,000 for an individual, \$40,500 for a body corporate and \$1,620,000 for a utility that is a body corporate.

NSW	Not declared	Minister for Health, <a href="#">Public Health Act 2010 (NSW)</a>	Evidence (Audio and Audio Visual Links) Amendment (Emergency Measures-COVID-19) Regulation 2020  Crimes (Administration of Sentences) Amendment (COVID-19) Regulation 2020  <i>COVID-19 Legislation Amendment (Emergency Measures) Act 2020 No 1</i>	As <a href="#">at 21 July</a> , anyone wanting to enter NSW from Victoria (or who has been in Victoria in the last 14 days) will need a border entry permit. In almost all cases, permits will indicate that 14 days of quarantine is required for those travelling from Victoria to NSW.	<i>Public Health Act 2010 (NSW) s 17</i> , individuals face up to 6 months' imprisonment and a fine of up to \$11,000, plus \$5,500 fine each day the offence continues. Corporations are liable to a fine of \$55,000 and \$27,500 each day the offence continues.
NT	18 March 2020	Chief Health Officer, <a href="#">Public and Environmental Health Act 2011 (NT)</a>	N/A	According to the <a href="#">Directions</a> issued on 17 July, anyone arriving into the NT from a hotspot (including Victoria) must do 14 days of mandatory supervised quarantine at their own cost.	<i>Public and Environmental Health Act 2011 (NT) s 52</i> , up to \$62,800.00 for an individual and \$314,000 for a body corporate.  <i>The Public and Environmental Health Amendment Regulations 2020 (NT)</i> introduced on-the-spot fines of \$1,099 for individuals and \$5,459 for bodies corporate for failing to comply with emergency declarations and directions.
Tas	17 March 2020, <a href="#">Public Health Act 1997 (Tas)</a>  Declaration of a State of Emergency on 19 March, <a href="#">Emergency Management Act 2006 (Tas)</a>	State Controller, <i>Public Health Act 1997 (Tas)</i> Tasmanian Director of Public Health, <i>Emergency Management Act 2006 (Tas)</i>	<i>COVID-19 Disease Emergency Miscellaneous Provisions Act 2020 (Tas)</i>	<a href="#">Directions</a> from 17 July state that any person who has been in a declared Affected Region (including Victoria) within the last 14 days is not permitted to enter Tasmania.  Every person who arrives in Tasmania (after 12:01am 17 July 2020) from a departure point outside Tasmania, is required to isolate for 14 days.	<i>Public Health Act 1997 (Tas) s 16</i> , maximum penalty of 100 penalty units or \$16,800 for an individual, six months imprisonment, or both. If a body corporate is guilty of an offence, each director of the body corporate is guilty of the offence unless it is proved that the director could not have reasonably prevented the commission of the offence by the body corporate.

<p><b>WA</b></p>	<p>Declaration of a State of Emergency on 15 March, <a href="#">Emergency Management Act 2005 (WA)</a>.</p> <p>16 March, public health state of emergency, declared, <a href="#">Public Health Act 2016 (WA)</a></p>	<p>The Minister, <i>Public Health Act 2016 (WA)</i> and <i>Emergency Management Act 2005 (WA)</i></p>	<p><i>Emergency Management Amendment (COVID-19 Response) Act 2020 (WA)</i></p>	<p>As at 10 July, anyone arriving in WA who has been to or transited through Victoria or NSW in the past 14 days will be required to self-quarantine for 14 days.</p>	<p><i>Public Health Act 2016 (WA)</i> s 202, penalty of \$50,000 plus \$5,000 for each separate and further offence for an individual and \$250,000 plus \$25,000 for each separate and further offence for a body corporate.</p>
<p><b>SA</b></p>	<p>15 March 2020, <a href="#">Public Health Act 2011 (SA)</a></p> <p>Declaration of a 'Major Emergency' on 22 March, <a href="#">Emergency Management Act 2004 (SA)</a></p>	<p>Chief Executive, <i>Public Health Act 2011 (SA)</i></p> <p>State Co-Ordinator, <i>Emergency Management Act 2004 (SA)</i></p>	<p>N/A</p>	<p>As at 29 July 2020, only essential travellers will be able to enter SA from Victoria. South Australians will no longer be able to return to SA from Victoria.</p> <p>Travellers from NT, Qld, Tas and WA are able to enter South Australia directly without restriction.</p> <p>Travellers from ACT and NSW, other than essential travellers, are required to self-quarantine for 14 days after entering SA.</p>	<p><i>Public Health Act 2011 (SA)</i> s 57, maximum penalty for individuals is \$250,000, 5 years' imprisonment, or both.</p> <p>Directions from the Police Commissioner under the Emergency Management Act introduced on-the-spot fines of \$1,000 for individuals failing to self-isolate and \$5,000 for businesses failing to follow laws relating to the pandemic.</p>



## Appendix: Chronology of Directions made by Victorian Government in response to COVID-19 pandemic

Date made	Came into force	Direction/Requirement/Declaration	Gazette	Source of the power
16 March		Declaration: State of Emergency	<a href="#">Special Gazette No. S 129 Monday 16 March 2020</a>	Section 198(1) of the <i>Public Health and Wellbeing Act 2008</i>
18 March	5pm 18 March	Mass Gatherings Direction	<a href="#">Special Gazette No. S 135 Thursday 19 March 2020</a>	Sections 200(1)(b) and 200(1)(d) of the <i>Public Health and Wellbeing Act 2008</i>
18 March	5pm 18 March	Airport Arrivals Direction	<a href="#">Special Gazette No. S 135 Thursday 19 March 2020</a>	Sections 200(1)(b) and 200(1)(d) of the <i>Public Health and Wellbeing Act 2008</i>
19 March	1:30pm 19 March	Cruise Ship Docking Direction	<a href="#">Special Gazette No. S 139 Friday 20 March 2020</a>	Sections 200(1)(b) and 200(1)(d) of the <i>Public Health and Wellbeing Act 2008</i>
21 March	Midnight 21 March	Mass Gatherings Direction (No. 2)	<a href="#">Special Gazette No. S 142 Sunday 22 March 2020</a>	Sections 200(1)(b) and (d) of the <i>Public Health and Wellbeing Act 2008</i>
21 March	6pm 21 March Midnight 18 March	Visitors To Residential Aged Care Facilities Direction	<a href="#">Special Gazette No. S 142 Sunday 22 March 2020</a>	Sections 200(1)(b) and 200(1)(d) of the <i>Public Health and Wellbeing Act 2008</i>
23 March	Noon 23 March	Non-essential Business Closure Direction	<a href="#">Special Gazette No. S 144 Monday 23 March 2020</a>	Sections 190(1)(a) and 200(1)(d) <i>Public Health and Wellbeing Act 2008</i> (Vic.)
23 March	Midnight 23 March	Hospital Visitors Direction	<a href="#">Special Gazette No. S 147 Tuesday 24 March 2020</a>	Sections 200(1)(b) and (d) of the <i>Public Health and Wellbeing Act 2008</i>
25 March	Midnight 25 March	Isolation (Diagnosis) Direction	<a href="#">Special Gazette No. S 155 Thursday 26 March 2020</a>	Sections 200(1)(b) and (d) of the <i>Public Health and Wellbeing Act 2008</i>
25 March	Midnight 25 March	Prohibited Gatherings Direction	<a href="#">Special Gazette No. S 156 Thursday 26 March 2020</a>	Sections 200(1)(b) and (d) of the <i>Public Health and Wellbeing Act 2008</i>
25 March	Midnight 25 March	Non-essential Activity Direction	<a href="#">Special Gazette No. S 156 Thursday 26 March 2020</a>	Sections 190(1)(a) and (g) and 200(1)(d) of the <i>Public Health and Wellbeing Act 2008</i>
26 March	Midnight 26 March	Non-essential Activity (No. 2) Direction	<a href="#">Special Gazette No. S 161 Friday 27 March 2020</a>	Sections 190(1)(a) and (g) and 200(1)(d) <i>Public Health and Wellbeing Act 2008</i>

28 March	Midnight 28 March	Revocation of Airport Arrivals and Cruise Ship Docking Direction	<a href="#">Special Gazette No. S 167 Monday 30 March 2020</a>	Sections 200(1)(b) and (d) <i>Public Health and Wellbeing Act 2008</i>
30 March	Midnight 30 March	Restricted Activity Direction	<a href="#">Special Gazette No. S 169 Tuesday 31 March 2020</a>	Sections 190(1)(a) and (g) and 200(1)(d) <i>Public Health and Wellbeing Act 2008</i>
30 March	Midnight 30 March	Stay at Home Direction	<a href="#">Special Gazette No. S 169 Tuesday 31 March 2020</a>	Sections 200(1)(b) and (d) <i>Public Health and Wellbeing Act 2008</i>
2 April	Midnight 2 April	Stay at Home Direction (No. 2)	<a href="#">Special Gazette No. S 177 Thursday 3 April 2020</a>	Sections 200(1)(b) and (d) <i>Public Health and Wellbeing Act 2008</i>
3 April		Ministers of the Crown: Commissioning of the Crisis Council of Cabinet	<a href="#">Special Gazette No. S 180 Friday 3 April 2020</a>	
7 April	Midnight 7 April	Care Facilities Direction	<a href="#">Special Gazette No. S 191 Wednesday 8 April 2020</a>	Sections 200(1)(b) and (d) <i>Public Health and Wellbeing Act 2008</i>
7 April	Midnight 7 April	Restricted Activity Direction (No. 2)	<a href="#">Special Gazette No. S 191 Wednesday 8 April 2020</a>	Sections 190(1)(a) and (g) and 200(1)(d) <i>Public Health and Wellbeing Act 2008</i>
7 April	Midnight 7 April	Stay at Home Direction (No. 3)	<a href="#">Special Gazette No. S 191 Wednesday 8 April 2020</a>	Sections 200(1)(b) and (d) <i>Public Health and Wellbeing Act 2008</i>
12 April		Declaration: Extension of State of Emergency	<a href="#">Special Gazette No. S 193 Sunday 12 April 2020</a>	Section 198(1) of the <i>Public Health and Wellbeing Act 2008</i>
13 April	Midnight 13 April	Restricted Activity Direction (No. 3)	<a href="#">Special Gazette No. S 194 Tuesday 14 April 2020</a>	Sections 190(1)(a) and (g) and 200(1)(d) <i>Public Health and Wellbeing Act 2008</i>
13 April	Midnight 13 April	Care Facilities Direction (No. 2)	<a href="#">Special Gazette No. S 194 Tuesday 14 April 2020</a>	Sections 200(1)(b) and (d) <i>Public Health and Wellbeing Act 2008</i>
13 April	Midnight 13 April	Hospital Visitor Direction (No. 2)	<a href="#">Special Gazette No. S 194 Tuesday 14 April 2020</a>	Sections 200(1)(b) and (d) <i>Public Health and Wellbeing Act 2008</i>
13 April	Midnight 13 April	Stay at Home Direction (No. 4)	<a href="#">Special Gazette No. S 194 Tuesday 14 April 2020</a>	Sections 200(1)(b) and (d) <i>Public Health and Wellbeing Act 2008</i>
13 April	Midnight 13 April	Isolation (Diagnosis) Direction (No. 2)	<a href="#">Special Gazette No. S 194 Tuesday 14 April 2020</a>	Sections 200(1)(b) and (d) <i>Public Health and Wellbeing Act 2008</i>
17 April	Midnight 17 April	Restricted Activity Direction (No. 4)	<a href="#">Special Gazette No. S 199 Saturday 18 April 2020</a>	Sections 190(1)(a) and (g) and 200(1)(d) <i>Public Health and Wellbeing Act 2008</i>

24 April	Midnight 24 April	Restricted Activity Direction (No. 5)	<a href="#">Special Gazette No. S 206 Saturday 25 April 2020</a>	Sections 190(1)(a) and (g) and 200(1)(d) <i>Public Health and Wellbeing Act 2008</i>
11 May	Midnight 11 May	Declaration: Extension of the Declaration of Emergency	<a href="#">Special Gazette No. S 231 Tuesday 12 May 2020</a>	Section 198(1) <i>Public Health and Wellbeing Act 2008</i>
11 May	Midnight 11 May	Restricted Activity Direction (No. 6)	<a href="#">Special Gazette No. S 231 Tuesday 12 May 2020</a>	Section 200(1)(d) <i>Public Health and Wellbeing Act 2008</i>
11 May	Midnight 11 May	Care Facilities Direction (No. 3)	<a href="#">Special Gazette No. S 231 Tuesday 12 May 2020</a>	Sections 200(1)(b) and (d) <i>Public Health and Wellbeing Act 2008</i>
11 May	Midnight 11 May	Stay at Home Direction (No. 5)	<a href="#">Special Gazette No. S 231 Tuesday 12 May 2020</a>	Sections 200(1)(b) and (d) <i>Public Health and Wellbeing Act 2008</i>
11 May	Midnight 11 May	Hospital Visitors Directions (No. 3)	<a href="#">Special Gazette No. S 231 Tuesday 12 May 2020</a>	Sections 200(1)(b) and (d) <i>Public Health and Wellbeing Act 2008</i>
11 May	Midnight 11 May	Diagnosed Persons and Close Contact Direction	<a href="#">Special Gazette No. S 231 Tuesday 12 May 2020</a>	Sections 200(1)(b) and (d) <i>Public Health and Wellbeing Act 2008</i>
11 May	11:59pm 12 May	Restricted Activity Direction (No. 7)	<a href="#">Special Gazette No. S 231 Tuesday 12 May 2020</a>	Section 200(1)(d) <i>Public Health and Wellbeing Act 2008</i>
12 May	11:59pm 12 May	Stay at Home Direction (No. 6)	<a href="#">Special Gazette No. S 231 Tuesday 12 May 2020</a>	Sections 200(1)(b) and (d) <i>Public Health and Wellbeing Act 2008</i>
24 May	11:59pm 25 May	Restricted Activity Direction (No. 8)	<a href="#">Special Gazette No. S 253 Monday 25 May 2020</a>	Section 200(1)(d) <i>Public Health and Wellbeing Act 2008</i>
24 May	11:59pm 25 May	Stay at Home Direction (No. 7)	<a href="#">Special Gazette No. S 253 Monday 25 May 2020</a>	Sections 200(1)(b) and (d) <i>Public Health and Wellbeing Act 2008</i>
31 May	11:59pm 31 May	Declaration: Extension of State of Emergency	<a href="#">Special Gazette No. S 267 Monday 1 June 2020</a>	Section 198(1) <i>Public Health and Wellbeing Act 2008</i>
31 May	11:59pm 31 May	Care Facilities Direction (No. 4)	<a href="#">Special Gazette No. S 267 Monday 1 June 2020</a>	Sections 200(1)(b) and (d) <i>Public Health and Wellbeing Act 2008</i>
31 May	11:59pm 31 May	Hospital Visitor Direction (No. 4)	<a href="#">Special Gazette No. S 267 Monday 1 June 2020</a>	Sections 200(1)(b) and (d) <i>Public Health and Wellbeing Act 2008</i>
31 May	11:59pm 31 May	Diagnosed Persons and Close Contacts Direction (No. 2)	<a href="#">Special Gazette No. S 267 Monday 1 June 2020</a>	Sections 200(1)(b) and (d) <i>Public Health and Wellbeing Act 2008</i>

31 May	11:59pm 31 May	Restricted Activity Direction (No. 9)	<a href="#">Special Gazette No. S 267 Monday 1 June 2020</a>	Section 200(1)(d) <i>Public Health and Wellbeing Act 2008</i>
31 May	11:59pm 31 May	Stay Safe Direction	<a href="#">Special Gazette No. S 267 Monday 1 June 2020</a>	Sections 200(1)(b) and (d) <i>Public Health and Wellbeing Act 2008</i>
16 June	11:59pm 16 June	Hospital Visitor Direction (No. 5)	<a href="#">Special Gazette No. S 289 Wednesday 17 June 2020</a>	Sections 200(1)(b) and (d) <i>Public Health and Wellbeing Act 2008</i>
21 June	11:59pm 21 June	Declaration: Extension of State of Emergency	<a href="#">Special Gazette No. S 297 Monday 22 June 2020</a>	Section 198(1) <i>Public Health and Wellbeing Act 2008</i>
21 June	11:59pm 21 June	Diagnosed Persons and Close Contacts Direction (No. 3)	<a href="#">Special Gazette No. S 297 Monday 22 June 2020</a>	Sections 200(1)(b) and (d) <i>Public Health and Wellbeing Act 2008</i>
21 June	11:59pm 21 June	Hospital Visitor Direction (No. 6)	<a href="#">Special Gazette No. S 297 Monday 22 June 2020</a>	Sections 200(1)(b) and (d) <i>Public Health and Wellbeing Act 2008</i>
21 June	11:59pm 21 June	Care Facilities Direction (No. 5)	<a href="#">Special Gazette No. S 297 Monday 22 June 2020</a>	Sections 200(1)(b) and (d) <i>Public Health and Wellbeing Act 2008</i>
21 June	11:59pm 21 June	Stay Safe Direction (No. 2)	<a href="#">Special Gazette No. S 297 Monday 22 June 2020</a>	Sections 200(1)(b) and (d) <i>Public Health and Wellbeing Act 2008</i>
21 June	11:59pm 21 June	Restricted Activity Direction (No. 10)	<a href="#">Special Gazette No. S 297 Monday 22 June 2020</a>	Section 200(1)(d) <i>Public Health and Wellbeing Act 2008</i>
1 July	11:59pm 1 July	Area Directions	<a href="#">Special Gazette No. S 339, Thursday 2 July 2020</a>	Sections 200(1)(b) and (d) <i>Public Health and Wellbeing Act 2008</i>
1 July	11:59pm 1 July	Stay at Home Directions (Restricted Postcodes)	<a href="#">Special Gazette No. S 339, Thursday 2 July 2020</a>	Sections 200(1)(b) and (d) <i>Public Health and Wellbeing Act 2008</i>
1 July	11:59pm 1 July	Restricted Activity Directions (Restricted Postcodes)	<a href="#">Special Gazette No. S 339, Thursday 2 July 2020</a>	Section 200(1)(d) <i>Public Health and Wellbeing Act 2008</i>
1 July	11:59pm 1 July	Hospital Visitor Directions (No. 7)	<a href="#">Special Gazette No. S 339, Thursday 2 July 2020</a>	Sections 200(1)(b) and (d) <i>Public Health and Wellbeing Act 2008</i>
1 July	11:59pm 1 July	Diagnosed Persons and Close Contacts Directions (No. 4)	<a href="#">Special Gazette No. S 339, Thursday 2 July 2020</a>	Sections 200(1)(b) and (d) <i>Public Health and Wellbeing Act 2008</i>
1 July	11:59pm 1 July	Care Facilities Directions (No. 6)	<a href="#">Special Gazette No. S 339, Thursday 2 July 2020</a>	Sections 200(1)(b) and (d) <i>Public Health and Wellbeing Act 2008</i>

1 July	11:59pm 1 July	Stay Safe Directions (No. 3)	<a href="#">Special Gazette No. S 339, Thursday 2 July 2020</a>	Sections 200(1)(b) and (d) <i>Public Health and Wellbeing Act 2008</i>
1 July	11:59pm 1 July	Restricted Activity Directions (No. 11)	<a href="#">Special Gazette No. S 339, Thursday 2 July 2020</a>	Section 200(1)(d) <i>Public Health and Wellbeing Act 2008</i>
4 July	11:59pm 4 July	Area Directions (No. 2)	<a href="#">Special Gazette No. S 343, Sunday 5 July 2020</a>	Sections 200(1)(b) and (d) <i>Public Health and Wellbeing Act 2008</i>
4 July	03:30pm 4 July	Detention Directions - 12 Sutton Street North Melbourne	<a href="#">Special Gazette No. S 343, Sunday 5 July 2020</a>	Sections 200(1)(a), (b) and (d) <i>Public Health and Wellbeing Act 2008</i>
4 July	03:30pm 4 July	Detention Directions - 33 Alfred Street North Melbourne	<a href="#">Special Gazette No. S 343, Sunday 5 July 2020</a>	Sections 200(1)(a), (b) and (d) <i>Public Health and Wellbeing Act 2008</i>
4 July	03:30pm 4 July	Detention Directions - 76 Canning Street North Melbourne	<a href="#">Special Gazette No. S 343, Sunday 5 July 2020</a>	Sections 200(1)(a), (b) and (d) <i>Public Health and Wellbeing Act 2008</i>
4 July	03:30pm 4 July	Detention Directions - 159 Melrose Street North Melbourne	<a href="#">Special Gazette No. S 343, Sunday 5 July 2020</a>	Sections 200(1)(a), (b) and (d) <i>Public Health and Wellbeing Act 2008</i>
4 July	03:30pm 4 July	Detention Directions - 9 Pampas Street North Melbourne	<a href="#">Special Gazette No. S 343, Sunday 5 July 2020</a>	Sections 200(1)(a), (b) and (d) <i>Public Health and Wellbeing Act 2008</i>
4 July	03:30pm 4 July	Detention Directions - 12 Holland Court Flemington	<a href="#">Special Gazette No. S 343, Sunday 5 July 2020</a>	Sections 200(1)(a), (b) and (d) <i>Public Health and Wellbeing Act 2008</i>
4 July	03:30pm 4 July	Detention Directions - 120 Racecourse Road Flemington	<a href="#">Special Gazette No. S 343, Sunday 5 July 2020</a>	Sections 200(1)(a), (b) and (d) <i>Public Health and Wellbeing Act 2008</i>
4 July	03:30pm 4 July	Detention Directions - 126 Racecourse Road Flemington	<a href="#">Special Gazette No. S 343, Sunday 5 July 2020</a>	Sections 200(1)(a), (b) and (d) <i>Public Health and Wellbeing Act 2008</i>
4 July	03:30pm 4 July	Detention Directions - 130 Racecourse Road Flemington	<a href="#">Special Gazette No. S 343, Sunday 5 July 2020</a>	Sections 200(1)(a), (b) and (d) <i>Public Health and Wellbeing Act 2008</i>
8 July	11:59pm 8 July	Area Directions (No. 3)	<a href="#">Special Gazette No. S 346, Thursday 9 July 2020</a>	Sections 200(1)(a), (b) and (d) <i>Public Health and Wellbeing Act 2008</i>
8 July	11:59pm 8 July	Stay at Home Directions (Restricted Areas)	<a href="#">Special Gazette No. S 346, Thursday 9 July 2020</a>	Sections 200(1)(a), (b) and (d) <i>Public Health and Wellbeing Act 2008</i>
8 July	11:59pm 8 July	Restricted Activity Directions (Restricted Areas)	<a href="#">Special Gazette No. S 346, Thursday 9 July 2020</a>	Sections 200(1)(a), (b) and (d) <i>Public Health and Wellbeing Act 2008</i>

8 July	11:59pm 8 July	Stay Safe Directions (No. 4)	<a href="#">Special Gazette No. S 346, Thursday 9 July 2020</a>	Sections 200(1)(a), (b) and (d) <i>Public Health and Wellbeing Act 2008</i>
8 July	11:59pm 8 July	Restricted Activity Directions (No. 12)	<a href="#">Special Gazette No. S 346, Thursday 9 July 2020</a>	Sections 200(1)(a), (b) and (d) <i>Public Health and Wellbeing Act 2008</i>
9 July	11:59pm 9 July	Revocation of Detention Direction - 33 Alfred Street, North Melbourne	<a href="#">Special Gazette No. S 350, Friday 10 July 2020</a>	Sections 200(1)(a), (b) and (d) <i>Public Health and Wellbeing Act 2008</i>
9 July	11:59pm 9 July	Revocation of Detention Directions - 76 Canning Street, North Melbourne	<a href="#">Special Gazette No. S 350, Friday 10 July 2020</a>	Sections 200(1)(a), (b) and (d) <i>Public Health and Wellbeing Act 2008</i>
9 July	11:59pm 9 July	Revocation of Detention Directions - 120 Racecourse Road, Flemington	<a href="#">Special Gazette No. S 350, Friday 10 July 2020</a>	Sections 200(1)(a), (b) and (d) <i>Public Health and Wellbeing Act 2008</i>
9 July	11:59pm 9 July	Revocation of Detention Directions - 126 Racecourse Road, Flemington	<a href="#">Special Gazette No. S 350, Friday 10 July 2020</a>	Sections 200(1)(a), (b) and (d) <i>Public Health and Wellbeing Act 2008</i>
9 July	11:59pm 9 July	Revocation of Detention Directions - 130 Racecourse Road, Flemington	<a href="#">Special Gazette No. S 350, Friday 10 July 2020</a>	Sections 200(1)(a), (b) and (d) <i>Public Health and Wellbeing Act 2008</i>
9 July	11:59pm 9 July	Revocation of Detention Directions - 159 Melrose Street, North Melbourne	<a href="#">Special Gazette No. S 350, Friday 10 July 2020</a>	Sections 200(1)(a), (b) and (d) <i>Public Health and Wellbeing Act 2008</i>
9 July	11:59pm 9 July	Revocation of Detention Directions - 9 Pampas Street, North Melbourne	<a href="#">Special Gazette No. S 350, Friday 10 July 2020</a>	Sections 200(1)(a), (b) and (d) <i>Public Health and Wellbeing Act 2008</i>
9 July	11:59pm 9 July	Revocation of Detention Directions - 12 Holland Court, Flemington	<a href="#">Special Gazette No. S 350, Friday 10 July 2020</a>	Sections 200(1)(a), (b) and (d) <i>Public Health and Wellbeing Act 2008</i>
9 July	11:59pm 9 July	Revocation of Detention Directions - 12 Sutton Street, North Melbourne	<a href="#">Special Gazette No. S 350, Friday 10 July 2020</a>	Sections 200(1)(a), (b) and (d) <i>Public Health and Wellbeing Act 2008</i>
10 July	12:59pm 10 July	Stay Safe Directions (No. 5)	<a href="#">Special Gazette No. S 351, Friday 10 July 2020</a>	Sections 200(1)(a), (b) and (d) <i>Public Health and Wellbeing Act 2008</i>
10 July	12:59pm 10 July	Stay at Home Directions (Restricted Areas) (No. 2)	<a href="#">Special Gazette No. S 351, Friday 10 July 2020</a>	Sections 200(1)(a), (b) and (d) <i>Public Health and Wellbeing Act 2008</i>
15 July	11:59pm 15 July	Diagnosed Persons and Close Contacts Directions (No. 5)	<a href="#">Special Gazette No. S 351, Friday 10 July 2020</a>	Sections 200(1)(a), (b) and (d) <i>Public Health and Wellbeing Act 2008</i>
19 July	11:59pm 19 July	Extension of a Declaration of a State of Emergency – until 16 August 2020	<a href="#">Special Gazette No. S 361, Monday 20 July 2020</a>	Section 198(1) <i>Public Health and Wellbeing Act</i>



19 July	11:59pm 19 July	Area Directions (No. 4)	<a href="#">Special Gazette No. S 361, Monday 20 July 2020</a>	Sections 200(1)(b) and (d) <i>Public Health and Wellbeing Act 2008</i>
19 July	11:59pm 19 July	Stay at Home Directions (Restricted Areas) (No. 3)	<a href="#">Special Gazette No. S 361, Monday 20 July 2020</a>	Sections 200(1)(b) and (d) <i>Public Health and Wellbeing Act 2008</i>
19 July	11:59pm 19 July	Restricted Activity Directions (Restricted Areas) (No. 2)	<a href="#">Special Gazette No. S 361, Monday 20 July 2020</a>	Section 200(1)(d) <i>Public Health and Wellbeing Act 2008</i>
19 July	11:59pm 19 July	Stay Safe Directions (No. 6)	<a href="#">Special Gazette No. S 361, Monday 20 July 2020</a>	Sections 200(1)(b) and (d) <i>Public Health and Wellbeing Act 2008</i>
19 July	11:59pm 19 July	Restricted Activity Directions (No. 13)	<a href="#">Special Gazette No. S 361, Monday 20 July 2020</a>	Section 200(1)(d) <i>Public Health and Wellbeing Act 2008</i>
19 July	11:59pm 19 July	Diagnosed Persons and Close Contacts Directions (No. 6)	<a href="#">Special Gazette No. S 361, Monday 20 July 2020</a>	Sections 200(1)(b) and (d) <i>Public Health and Wellbeing Act 2008</i>
19 July	11:59pm 19 July	Hospital Visitor Directions (No. 8)	<a href="#">Special Gazette No. S 361, Monday 20 July 2020</a>	Sections 200(1)(b) and (d) <i>Public Health and Wellbeing Act 2008</i>
19 July	11:59pm 19 July	Care Facilities Directions (No. 7)	<a href="#">Special Gazette No. S 361, Monday 20 July 2020</a>	Sections 200(1)(b) and (d) <i>Public Health and Wellbeing Act 2008</i>
21 July	11:59pm 22 July	Stay Safe Directions (No. 7)	<a href="#">Special Gazette No. S 367, Thursday 23 July 2020</a>	Sections 200(1)(b) and (d) <i>Public Health and Wellbeing Act 2008</i>
21 July	11:59pm 22 July	Restricted Activity Directions (No. 14)	<a href="#">Special Gazette No. S 367, Thursday 23 July 2020</a>	Section 200(1)(d) <i>Public Health and Wellbeing Act 2008</i>
21 July	11:59pm 22 July	Diagnosed Persons and Close Contacts Directions (No. 7)	<a href="#">Special Gazette No. S 367, Thursday 23 July 2020</a>	Sections 200(1)(b) and (d) <i>Public Health and Wellbeing Act 2008</i>
22 July	11:59pm 22 July	Stay at Home Directions (Restricted Areas) (No. 4)	<a href="#">Special Gazette No. S 367, Thursday 23 July 2020</a>	Sections 200(1)(b) and (d) <i>Public Health and Wellbeing Act 2008</i>
22 July	11:59pm 22 July	Restricted Activity Directions (Restricted Areas) (No. 3)	<a href="#">Special Gazette No. S 367, Thursday 23 July 2020</a>	Section 200(1)(d) <i>Public Health and Wellbeing Act 2008</i>
22 July	11:59pm 22 July	Hospital Visitor Directions (No. 9)	<a href="#">Special Gazette No. S 367, Thursday 23 July 2020</a>	Sections 200(1)(b) and (d) <i>Public Health and Wellbeing Act 2008</i>
22 July	11:59pm 22 July	Care Facilities Directions (No. 8)	<a href="#">Special Gazette No. S 367, Thursday 23 July 2020</a>	Sections 200(1)(b) and (d) <i>Public Health and Wellbeing Act 2008</i>

30 July	11:59pm 30 July	Stay at Home Directions (Restricted Areas) (No. 5)	<a href="#">Special Gazette No. S 382, Friday 31 July 2020</a>	Sections 200(1)(b) and (d) <i>Public Health and Wellbeing Act 2008</i>
30 July	11:59pm 30 July	Area Directions (No. 5)	<a href="#">Special Gazette No. S 382, Friday 31 July 2020</a>	Sections 200(1)(b) and (d) <i>Public Health and Wellbeing Act 2008</i>
30 July	11:59pm 30 July	Restricted Activity Directions (No. 15)	<a href="#">Special Gazette No. S 382, Friday 31 July 2020</a>	Section 200(1)(d) <i>Public Health and Wellbeing Act 2008</i>
30 July	11:59pm 30 July	Stay Safe Directions (No. 8)	<a href="#">Special Gazette No. S 382, Friday 31 July 2020</a>	Sections 200(1)(b) and (d) <i>Public Health and Wellbeing Act 2008</i>
2 August	6:00pm 2 August	Declaration: State of Disaster	<a href="#">Special Gazette No. S 383, Sunday 2 August 2020</a>	Section 23(1) <i>Emergency Management Act 1986</i>
2 August	6:00pm 2 August	Stay at Home Directions (Restricted Areas) (No. 6)	<a href="#">Special Gazette No. S 384, Monday 3 August 2020</a>	Sections 200(1)(b) and (d) <i>Public Health and Wellbeing Act 2008</i>
2 August	7:59pm 2 August	Stay at Home Directions (Restricted Areas) (No. 7)	<a href="#">Special Gazette No. S 384, Monday 3 August 2020</a>	Sections 200(1)(b) and (d) <i>Public Health and Wellbeing Act 2008</i>
2 August	11:59pm 2 August	Stay Safe Directions (No. 9)	<a href="#">Special Gazette No. S 384, Monday 3 August 2020</a>	Sections 200(1)(b) and (d) <i>Public Health and Wellbeing Act 2008</i>
2 August	11:59pm 2 August	Restricted Activity Directions (No. 16)	<a href="#">Special Gazette No. S 384, Monday 3 August 2020</a>	Section 200(1)(d) <i>Public Health and Wellbeing Act 2008</i>
2 August	11:59pm 2 August	Restricted Activity Directions (Restricted Areas) (No. 4)	<a href="#">Special Gazette No. S 384, Monday 3 August 2020</a>	Section 200(1)(d) <i>Public Health and Wellbeing Act 2008</i>
2 August	11:59pm 2 August	Restricted Activity Directions (Restricted Areas) (No. 5)	<a href="#">Special Gazette No. S 384, Monday 3 August 2020</a>	Section 200(1)(d) <i>Public Health and Wellbeing Act 2008</i>
3 August	11:59pm 3 August	Diagnosed Persons and Close Contacts Directions (No. 8)	<a href="#">Special Gazette No. S 387, Tuesday 4 August 2020</a>	Sections 200(1)(b) and (d) <i>Public Health and Wellbeing Act 2008</i>
3 August	11:59pm 3 August	Care Facilities Directions (No. 9)	<a href="#">Special Gazette No. S 387, Tuesday 4 August 2020</a>	Sections 200(1)(b) and (d) <i>Public Health and Wellbeing Act 2008</i>

# References

---

## Relevant Legislation, Regulations and Plans

### Victorian Legislation

- *Charter of Human Rights and Responsibilities Act 2006* (Vic)
- *COVID-19 Omnibus (Emergency Measures) Act 2020* (Vic)
- *Emergency Management Act 1986* (Vic)
- *Emergency Management Act 2013* (Vic)
- *Essential Services Act 1958* (Vic)
- *Fuel Emergency Act 1977* (Vic)
- *Health Act 1958* (Vic)
- *Health Services Act 1988* (Vic)
- *Public Health and Wellbeing Act 2008* (Vic)
- *Public Safety Preservation Act 1923* (Vic)
- *Public Safety Preservation Act 1928* (Vic)
- *Public Safety Preservation Act 1958* (Vic)
- *State Disasters Act 1983*

### Legislation in other jurisdictions

- *Commonwealth of Australia Constitution Act* (Cth)
- *Biosecurity Act 2015* (Cth)
- *Coronavirus Economic Response Package Omnibus Act 2020* (Cth)
- *Disaster Management Act 2003* (Qld)
- *Emergencies Act 2004* (ACT)
- *Emergency Management Act 2004* (SA)
- *Emergency Management Act 2005* (WA)
- *Emergency Management Act 2006* (Tas)
- *Emergency Management Act 2013* (NT)
- *Emergency Powers Act 1920* (UK)
- *Human Rights (Parliamentary Scrutiny) Act 2011* (Cth)
- *National Health Security Act 2007* (Cth)
- *Privacy Act 1988* (Cth)
- *Privacy Amendment (Public Health Contact Information) Act 2020* (Cth)
- *Quarantine Act 1908* (Cth)
- *State Emergency and Rescue Management Act 1989* (NSW)
- *Public Health Act 2010* (NSW)
- *Public Health Act 2005* (Qld)
- *South Australian Public Health Act 2011* (SA)
- *Public Health Act 1997* (Tas)
- *Public Health Act 2016* (WA)
- *Public Health Act 1997* (ACT)
- *Public and Environmental Health Act 2011* (NT)
- *Human Rights Act 2004* (ACT)
- *Human Rights Act 2019* (Qld)

### Case law

- *Attorney-General (Vic) ex rel Dale v Commonwealth* (1945) 71 CLR 237.
- *Pape vs Commissioner of Taxation* (2009) 238 CLR 1.

## Parliamentary debates

- Andrews, D. (Minister for Health) (2008) [‘Second reading speech: Public Health and Wellbeing Bill’](#), *Debates*, Victoria, Legislative Assembly, 8 May.
- Andrews, D. (Minister for Health) (2008) [‘Statement of Compatibility: Public Health and Wellbeing Bill’](#), *Debates*, Victoria, Legislative Assembly, 8 May
- Premier of Victoria (2020) [‘Second reading speech: COVID-19 Omnibus \(Emergency Measures\) Bill 2020’](#), *Debates*, Victoria, Legislative Assembly, 23 April.

## Government and Independent Reports

- Australian Institute for Disaster Resilience (2019) [Australian Disaster Resilience Handbook Collection: Health and Disaster Management](#), Canberra, Department of Home Affairs.
- Australian Institute for Disaster Resilience (2019) [Australian Emergency Management Arrangements](#), Canberra, Department of Home Affairs.
- Australian National Audit Office (2017) [Department of Health’s Coordination of Communicable Disease Emergencies](#), Auditor-General Performance Audit, Canberra, Commonwealth of Australia.
- Beale, R., J. Fairbrother, A. Inglis and D. Trebeck (2008) [One biosecurity: a working partnership](#), Canberra, Quarantine and Biosecurity Review Panel and Department of Agriculture, Fisheries and Forestry.
- Burn, M. E, Moore, C. and A. Gissing (2019) [The potential role of the commonwealth in responding to catastrophic disasters](#), Melbourne, Bushfire and Natural Hazards CRC.
- Comrie, N. (2011) [Review of the 2010-11 Flood Warnings & Response: final report](#), Melbourne, The Review.
- Department for Health and Wellbeing (2020) [Management of COVID-19 in residential aged care](#), fact sheet, Adelaide, South Australian Government.
- Department of Agriculture, Fisheries and Forestry (2008) [Review of Australia’s Quarantine and Biosecurity Arrangements - Report and Australian Government Preliminary Response](#), Canberra, Australian Government.
- Department of Health (2020) [Australian Health Protection Principal Committee \(AHPPC\)](#), Canberra, Australian Government.
- Department of Primary Industries and Energy (1996) [Australian Quarantine a shared responsibility: The Nairn report](#), Canberra, Australian Government.
- Mikakos, J. (Minister for Health) (2020) [Report to Parliament on the declaration of a state of emergency: report under section 198\(8\) of the Public Health and Wellbeing Act 2008](#), Melbourne, Victorian Government.
- NSW Health (2020) [Guiding principles for safe and efficient admissions into Residential Aged Care Facilities and transfers to hospital during the COVID-19 pandemic](#), Sydney, NSW Government.
- Royal Commission into Aged Care Quality and Safety (2019) [Interim Report: Neglect](#), 3 Volumes, Canberra, Commonwealth of Australia.
- Royal Commission into Natural Disaster Arrangements (2020) [Issues Paper: Constitutional Framework for the Declaration of a State of National Emergency](#), Canberra, Australian Government.
- Victorian Bushfires Royal Commission (2010) [Final Report. Vol 2](#), Melbourne, Government Printer.
- Victorian Bushfires Royal Commission (2010) [Final Report: Summary](#), Melbourne, Government Printer.

## Plans, Victoria

- Australian Institute for Disaster Resilience (2019) [Australian Emergency Management Arrangements](#), Canberra, Department of Home Affairs.
- Department of Health (2014) [Victorian health management plan for pandemic influenza](#), Melbourne, Victorian Government.
- DHHS (2020) [\(COVID-19\) Plan for the Victorian Aged Care Sector](#), Melbourne, Victorian Government.
- Emergency Management Victoria (2015) [Victorian action plan for influenza pandemic](#), Melbourne, Victorian Government.
- Emergency Management Victoria (2017) [State Health Emergency Response Plan](#). Edition 4, Melbourne, Victorian Government.
- Emergency Management Victoria (2017) [State Health Emergency Response Plan](#). Edition 4, Melbourne, Victorian Government.
- Emergency Management Victoria (2020) [Emergence Management Manual Victoria Part 7 – Emergency Management Agency Roles](#), Melbourne, Victorian Government.
- Mikakos, J. (Minister for Health) (2020) [COVID-19 Pandemic plan for the Victoria Health Sector](#), Melbourne, Victorian Government.

## Plans, Commonwealth

- Australian Institute for Disaster Resilience (2019) [Australian Disaster Resilience Handbook Collection: Health and Disaster Management](#), Canberra, Department of Home Affairs.
- Australian Institute for Disaster Resilience (2019) [Australian Disaster Resilience Handbook Collection: Health and Disaster Management](#), Canberra, Department of Home Affairs.
- Commonwealth Department of Health (2019) [Australian Health Management Plan for Pandemic Influenza](#), Canberra, Government of Australia.
- Commonwealth Department of Health (2020) [Australian Health Sector Emergency Response Plan for Novel Coronavirus \(COVID-19\)](#), Canberra, Australian Government.
- Department of Health (2019) [Australian Health Management Plan for Pandemic Influenza](#), Canberra, Commonwealth of Australia.
- Department of Health (2020) [Australian Health Sector Emergency Response Plan for Novel Coronavirus](#), Canberra, Commonwealth of Australia.
- Department of Health (2020) [Commonwealth and NSW protocol to help manage a COVID-19 outbreak in a residential aged care facility in NSW](#), Canberra, Commonwealth Government.

## Submissions

- Laschz, A. and M. Hurley (2020) 'Joint Submission: OPCAT, places of detention and COVID-19', *Inquiry into the Australian Government's response to the COVID-19 pandemic*, Canberra, The Committee.
- Australian Human Rights Institute (2020) '[Submission To The Parliamentary Joint Committee On Human Rights](#)', *Parliamentary Joint Committee on Human Rights*, Canberra, The Committee.
- Department of Prime Minister and Cabinet (2020) 'Whole-of-Government Submission', *Inquiry into the Australian Government's response to the COVID-19 pandemic*, Canberra, The Committee.
- Human Rights for All (2020) 'Prevention of COVID-19 infection and spread in Australia's immigration detention facilities', *Inquiry into the Australian Government's response to the COVID-19 pandemic*, Canberra, The Committee.
- Human Rights Law Centre (2020) Submission to the Senate Select Committee into COVID-19, *Inquiry into the Australian Government's response to the COVID-19 pandemic*, Canberra, The Committee.
- Victorian Government (2020) [Submission to the Senate Select Committee on COVID-19](#), *Inquiry into the Australian Government's response to the COVID-19 pandemic*, Canberra, The Committee.

## Works Cited

### Media reports

- (2004) '[Hospital's coal briquettes shortage proves costly](#)', *ABC News*, 13 January.
- (2020) '["Ham-fisted" lockdown of nine Melbourne public housing powers, some without confirmed COVID-19 cases, criticised](#)' *SBS News*, 6 July.
- (2020) '[1,000 ADF personnel deployed to help coronavirus response in Victoria](#)', *ABC News*, 13 July.
- (2020) '[Chief Medical Officer Brendan Murphy fronts Senate committee on Australia's coronavirus response](#)', *ABC News*, 23 April.
- (2020) '[Coronavirus funding offer for independent schools 'completely inappropriate'](#), Victorian Government says', *ABC News Online*, 29 April.
- (2020) '[Coronavirus: Federal government to join High Court challenge of WA's border closure](#)', *9News*, 14 June.
- (2020) '[Prime Minister Scott Morrison to address state border closures and economic recovery at National Cabinet](#)', *Perth Now*, 12 June.
- (2020) '[Victoria records 723 new coronavirus cases and 13 deaths in pandemic's deadliest day](#)', *ABC News*, 31 July.
- (2020) '[Victorian police issue more than 400 fines for coronavirus breaches over Easter weekend](#)', *ABC News*, 13 April.
- Bachelard, M. (2020) '[Who is responsible for aged care homes?](#)', *The Age*, 30 July.
- Bagshaw, E. (2020) '[Strange and foreign' coronavirus powers to forcibly detain Australians](#)', *The Age*, 3 March.
- Baker, R. (2020) '[200 police staff in quarantine as union urges state-of-disaster declaration](#)', *The Age*, 25 March.
- Bashan, Y. (2020) '[Coronavirus: NSW Police probe Ruby Princess health report](#)', *The Australian*, 16 April.
- Baxendale, R. (2020) '[Tender waived for security Victoria's quarantine hotels](#)', *The Australian*, 4 July.

- Blakkarly, J. (2020) 'Melbourne's public housing tenants voice concerns about 'prison-like' lockdown conditions', *SBS News*, 7 July.
- Borrello, E., E. Laschon and D. Weber (2020) 'Clive Palmer's WA border challenge backed by Attorney-General Christian Porter, document shows', *ABC News*, 31 July.
- Bunch, A. (2020) 'Qld border court fight may be too late', *News.com.au*, 16 June.
- Carmody, J. (2020) 'Commonwealth withdraws from Clive Palmer border case, Prime Minister's letter to WA Premier reveals', *ABC News*, 2 August.
- Carrasco, S., M. Faleh and N. Dangol (2020) 'Our lives matter – Melbourne public housing residents talk about why COVID-19 hits them hard', *The Conversation*, 24 July.
- Carroll, J. (2020) 'Coronavirus has seriously tested our border security', *The Conversation*, 30 March.
- Carroll, J. (2020) 'Coronavirus has seriously tested our border security', *The Conversation*, 30 March.
- Cockburn, P. (2020) 'How the coronavirus pandemic would look in Australia if Ruby Princess had never docked', *ABC News*, 23 April.
- Collett, M. (2020) 'Coronavirus restrictions: Where you can and can't travel around Australia as borders reopen', *ABC News*, 2 July.
- Crowe, D. (2020) 'Blame game won't help find a fix for the aged care corona crisis', *Sydney Morning Herald*, 28 July.
- Crowe, D. (2020) 'Privacy advocates raise new concerns with COVIDSafe app', *The Sydney Morning Herald*, 11 May.
- Dale, A. (2020) 'All out to sea', *Law Society Journal Online*, 4 May.
- Doherty, B. (2020) 'State leaders resist Morrison government push to reopen borders closed by coronavirus', *The Guardian*, 19 May.
- Doherty, B. (2020) 'State leaders resist Morrison government push to reopen borders closed by coronavirus', *The Guardian*, 19 May.
- Doran, M. (2020) 'Australians could be detained or forced into treatment to prevent the spread of coronavirus. Here's how', *ABC News*, 3 March.
- Estcourt, D. and C. Lucas (2020) 'Thousands of public housing tenants under hard lockdown as COVID-19 spreads', *The Age*, 4 July.
- Fowler, M. and C. Booker (2020) 'Anger at hard lockdown for towers without confirmed virus cases', *The Age*, 5 July.
- Fowler, M., R. Harris and S. Ilanbey (2020) 'Australia's top medical experts to spend Saturday deciding further Victorian restrictions', *The Age*, 31 July.
- Grattan, M. (2020) 'Coronavirus has made state borders a battle zone and premiers are manning the barricades', *ABC News*, 22 May.
- Grattan, M. (2020) 'First locally-transmitted COVID-19 cases in Australia, as Attorney-General warns drastic legal powers could be used', *The Conversation*, 2 March.
- Grattan, M. (2020) 'Hotel quarantine for returning Aussies and 'hibernation' assistance for businesses', *The Conversation*, 27 March.
- Grattan, M. (2020) 'Scott Morrison strengthens his policy power, enshrining national cabinet and giving it 'laser-like' focus on jobs', *The Conversation*, 29 May.
- Grattan, M. (2020) 'View from The Hill: Aged care crisis reflects poor preparation and a broken system', *The Conversation*, 28 July.
- Grattan, M. (2020) 'View from The Hill: Morrison government accepts Victorian closure but won't budge on High Court border challenge', *The Conversation*, 6 July.
- Greene, A. (2020) 'State of emergency: how different countries are invoking extra powers to stop the coronavirus', *The Conversation*, 31 March.
- Harvey, M. (2020) 'If COVID-19 is a national emergency, can the federal government take control of schools?', *The Conversation*, 1 May.
- Hayne, J. and G. Hitch (2020) 'Coronavirus app will not be forced upon Australians, Scott Morrison says', *ABC News*, 18 April.
- Henckels, C. and M. O'Sullivan (2020) 'Explainer: what are the laws mandating self-isolation and how will they be enforced?', *The Conversation*, 17 March.
- Hitch, G. and J. Hayne (2020) 'What's being done nationally to prevent coronavirus outbreaks in aged care homes?', *ABC News*, 28 July.
- Hondros, N. (2020) 'WA Premier to oppose PM's national state of emergency plan', *WAtoday*, 31 January.
- Hope, Z. (2020) 'State of disaster: Premier invoked powers for first time amid bushfire crisis', *The Age*, 2 January.
- Ilanbey, S. (2020) 'Sutton says resuming office work from July "not out the question"', 28 May.



- Judd, B. and C. Taylor (2020) 'Melbourne aged care is facing a coronavirus catastrophe. This is how it happened', *ABC News*, 29 July.
- Kaine, S., and E. Josserand (2020) 'Melbourne's hotel quarantine bungle is disappointing but not surprising. It was overseen by a flawed security industry', *The Conversation*, 8 July.
- Karp, P. (2020) 'Clive Palmer-backed court challenge to Queensland Covid-19 border closure dropped', *The Guardian*, 23 July.
- Karp, P. (2020) 'Coronavirus: what power does the Australian government have over you during crisis?', *The Guardian*, 3 March.
- Kehoe, J. (2020) 'States resist bushfire royal commission, oppose expansion of powers', *Australian Financial Review*, 14 January.
- Kelly, D. K. Shaw and L. Porter (2020) 'Melbourne tower lockdowns unfairly target already vulnerable public housing residents', *The Conversation*, 6 July.
- Kidd, J. (2020) 'Police in Ruby Princess coronavirus probe to question more than 5,500 passengers as global cases rise', *ABC News*, 17 April.
- Kontominas, B. (2020) 'Why the NSW border won't shut despite a spike in Victorian coronavirus cases', *ABC News Online*, 23 June.
- Lachson, E. and R. Trigger (2020) 'Coronavirus sees WA close its borders from midnight on Sunday to stop COVID-19 spread from eastern states', *ABC News*, 2 April.
- Lane, I. (2020) 'What Australia's 'extreme' new coronavirus laws and police powers mean for our civil liberties', *The New Daily*, 30 March.
- Lawson, K. (2020) 'COAG abolished, national cabinet here to stay', *Canberra Times*, 29 May.
- Livingston, A. (2020) 'Morrison wants power to declare national emergencies in disasters', *Sydney Morning Herald*, 29 January.
- Maguire, A. and B. Li (2020) 'Explainer: what are the Australian government's powers to quarantine people in a coronavirus outbreak?', *The Conversation*, 4 March.
- McCauley, D. (2020) 'Melbourne quarantine breach sparks calls for independent medical body', *The Age*, 25 June.
- McCauley, D., R. Harris and S. Ilanbey (2020) 'Military deployed to Melbourne's quarantine hotels', *Sydney Morning Herald*, 25 June.
- McGowan, M. A. Bull and J. Taylor (2020) 'Covid-19 lockdown: Victoria police data sparks fears disadvantaged unfairly targeted', 6 June.
- McInerney, M. (2020) 'What does killing off COAG mean for health, climate change, transparency and much more?' *Croakey Health Media*, 1 June.
- McNeil, H. (2020) "'Back off": Clive Palmer's Federal Court challenge to bring down WA's border begins', *The Age*, 27 July.
- Meixner, S. (2020) 'How many people have downloaded the COVIDSafe app and how central has it been to Australia's coronavirus response?', *ABC News*, 2 June.
- Merritt, C. (2020) 'Coronavirus Australia: See you in court, border rebels tell Anastacia Palaszczuk', *The Australian*, 2 June.
- Moloney, S. and K. Moloney (2020) 'Border closures, identity and political tensions: how Australia's past pandemics shape our COVID-19 response', *The Conversation*, 2 July.
- Morton, R. (2020) 'Forgotten lives: Covid-19 outbreaks in aged care', *The Saturday Paper*, 311, July 25–31.
- Norman, J. (2020) 'States under pressure to reopen borders closed in a bid to contain coronavirus', *ABC News*, 18 May.
- Norman, J. (2020) 'States under pressure to reopen borders closed in a bid to contain coronavirus', *ABC News*, 18 May.
- Patrick, A. (2020) 'The super spreader' event behind Australia's epidemic' *Australian Financial Review*, 27 March.
- RMIT ABC Fact Check Unit, 'Is it illegal under the constitution for a state to close its borders to other Australians?' *Crikey*, 23 April.
- RMIT ABC Fact Check Unit, 'Is it illegal under the constitution for a state to close its borders to other Australians?' *ABC News*, 23 April.
- Russell, L. (2020) 'COAG's out. It's a fresh chance to put health issues on the agenda, but there are risks', *The Conversation*, 10 June.
- Russo, P. (2020) 'Nine Melbourne tower blocks put into 'hard lockdown' – what does it mean, and will it work?' *The Conversation*, 5 July.
- Saunders, C. (2020) 'The National Cabinet has worked. Can it last?' *Pursuit*, 11 June.
- Schneiders, B. (2020) 'How hotel quarantine let COVID-19 out of the bag in Victoria', *The Age*, 3 July.
- Schultz, A. (2020) 'What's the difference between COAG and the national cabinet?', *Crikey*, 1 June.

- Seebeck, L. (2020) 'App is no silver bullet for virus, yet a honey pot for the malign', *Australian Financial Review*, 29 April.
- Shimwell, M. (2020) 'Compulsory isolation in the fight against coronavirus: a clash of human rights and public health' *The Conversation*, 3 March.
- Skatsoon, J. (2020) 'Councils sidelined as COAG abolished', *Government News*, online, 29 May.
- Smee, B. (2020) 'Clive Palmer launches high court challenge to Queensland coronavirus border closure', *The Guardian*, 28 May.
- Styles, A. (2020) "'This nonsense has to stop": McGowan calls on PM to stop supporting Palmer's border fight', *Sydney Morning Herald*, 6 July.
- Tham, J. (2020) 'COVID-19 ministerial powers need to be reined in', *Canberra Times*, 27 April.
- Thorne, L. (2020) 'Victoria's coronavirus quarantine program to get a "reset" after breaches', *ABC News*, 1 July.
- Tobin, G. and A. McDonald (2020) 'Coronavirus quarantine guards in Melbourne hotels were recruited via WhatsApp, then "told to bring their own masks"', *ABC News*, 22 July.
- Topsfield, J. and L. Mannix (2020) 'Aged care home had request to transfer virus cases to hospital denied', *The Age*, 16 July.
- Twomey, A. (2020) 'Explainer: what is a 'state of disaster' and what powers does it confer?', *The Conversation*, 2 August.
- Twomey, A. (2020) 'States are shutting their borders to stop coronavirus. Is that actually allowed?' *The Conversation*, 22 March.
- Twomey, A. (2020) 'We should bake in improvements to our federation', *The Australian*, 6 July.
- University of Sydney (2020) 'Experts examine the COVID-19 tracing app', *The University of Sydney*, 28 April.
- Varga, R. (2020) "'We're so isolated; it's like a prison'", *The Australian*, 6 July.
- Weekly Source (2020) 'Stand-off between States over national policy on transferring COVID-19 aged care residents to hospital leaves providers hanging', *The Weekly Source*, 1 July.
- Williams, G. (2020) 'Coronavirus: Queensland may be on a constitutional borderline', *The Australian*, 25 May.
- Wolfe, N. (2020) 'Coronavirus Victoria: Hundreds more police added to "Operational Sentinel"', *News.com.au*, 8 July.

## Media releases

- ACSA (2020) *Aged care COVID-19 outbreak response must not discriminate or ration hospital care*, media release, 22 June.
- ACSA (2020) *Hospitalisation of aged care residents should happen before major outbreaks*, media release, 28 July.
- ACT Government (2020) *Update on ACT/Victoria travel restrictions*, media release, 7 July.
- Australian Human Rights Commission (2020) *Commission position on the draft 'COVIDSafe App Bill'*, media release, 8 May.
- COAG (2020) *Meeting Communique*, 13 March.
- COAG (2020) *National Partnership on COVID-19 Response*, 13 March.
- Department of Prime Minister and Cabinet (2020) *COAG becomes National Cabinet*, media release, 2 June.
- Emergency Management Victoria (2020) *Eight months of activation at the State Control Centre*, media release, 13 May.
- Emergency Management Victoria (2020) *State of disaster extended for 48 hours*, media release, 9 January.
- Engage Victoria (2020) *Review of Victoria's Private Security Industry*, website.
- Human Rights Law Centre (2020) *Greater transparency needed around Federal Government's new COVID-19 phone app*, media release, 8 April.
- Human Rights Watch (2020) *Covid-19 Apps Pose Serious Human Rights Risks*, media release, 13 May.
- LASA (2020) *Aged care facilities are not hospitals*, media release, 6 March.
- LASA (2020) *Call for health system coordination to protect older Australians*, media release, 23 June.
- Law Council of Australia (2020) *Law Council of Australia President, Pauline Wright, statement regarding biosecurity control orders*, media release, 3 March.
- Liberty Victoria (2020) *Liberty Victoria concerned about consequences of omnibus bill for month-to-month residential tenancies*, media release, 29 April.
- Liberty Victoria (2020) *Refugee protest arrest and fines*, media release, 4 April.
- Minister for Aged Care and Senior Australians (2020) *Victorian Aged Care Response Centre*, media release, 27 July.
- Minister for Regional Development (2020) *Supporting Our Victorian And NSW Border Communities*, media release, 24 July.

National Security Committee of Cabinet (2020) [Media release: Updated travel advice to protect Australians from the novel coronavirus](#), media release, 1 February.

Neville, L., Minister for Police and Emergency Services (2020) [Police out in force to keep Victorians safe this Easter](#), media release, 9 April.

NSW Government (2020) [Border closure to protect NSW](#), media release, 6 July.

NSW Government (2020) [NSW and Victorian border closures](#), media release, 8 July.

NSW Government (2020) [Special commission of inquiry into Ruby Princess](#), media release, 15 April.

Parliament of Australia (2020) [Senate committee to continue to scrutinise delegated legislation, including COVID-19 related legislation](#), media release, 1 April.

Premier of Victoria (2020) [Enforced Quarantine For Returned Travellers To Combat Coronavirus](#), media release, 27 March.

Premier of Victoria (2020) [Face Coverings And Masks For Metro Schools](#), media release, 20 July.

Premier of Victoria (2020) [Judicial Inquiry Into Hotel Quarantine Program](#), media release, 2 July.

Premier of Victoria (2020) [More Australian Defence Force Personnel To Join Victoria's Coronavirus Response](#), 14 July.

Premier of Victoria (2020) [More Restrictions Put In Place In The Fight Against COVID-19](#), media release, 18 March.

Premier of Victoria (2020) [Premier's statement on changes to Melbourne's restrictions](#), media release, 2 August.

Premier of Victoria (2020) [State Control Centre Activated To Oversee COVID-19 Response](#), media release, 11 March.

Premier of Victoria (2020) [State of emergency declared in Victoria over COVID-19](#), media release, 16 March.

Premier of Victoria (2020) [Statement from the Premier](#), media release, 4 July.

Premier of Victoria (2020) [Statement from the Premier](#), media release, 7 July.

Premier of Victoria (2020) [Statement from the Premier](#), media release, 3 August.

Premier of Victoria (2020) [Statement on Changes to Melbourne's Restrictions](#), media release, 2 August.

Premier of Victoria (2020) [Victorian Government Declares A State Of Disaster](#), media release, 2 January.

Premier of Victoria (2020) [Working Together To Protect Our Aged Care Residents](#), media release, 28 July.

Prime Minister of Australia (2020) [National COVID-19 Coordination Commission](#), media release, 25 March.

Prime Minister of Australia (2020) [Press conference](#), transcript, 12 June.

Prime Minister of Australia (2020) [Transcript press conference](#), 15 March.

Prime Minister of Australia (2020) [Update following national cabinet meeting](#), media release, 29 May.

Prime Minister of Australia (2020) [Update on coronavirus measures](#), media statement, 18 March.

Prime Minister of Australia (2020) [Update on Coronavirus measures](#), media release, 27 March.

Prime Minister Scott Morrison (2020) [Transcript press conference](#), 17 February.

Prime Minister, Minister for Health, Chief Medical Officer (2020) [Advice on coronavirus](#), media release, 13 March.

Royal Commission into Aged Care Quality and Safety (2019) [Aged Care in Australia: A Shocking Tale of Neglect](#), media release, 31 October.

## Books

Dyzenhaus, D. (2006) *The Constitution of Law: Legality in a Time of Emergency*. Cambridge, Cambridge University Press.

Gross, O. and F. Ní Aoláin (2009) *Law in Times of Crisis: Emergency Powers in Theory and Practice*, Cambridge, Cambridge University Press.

Lee, H.P., M. Adams, C. Campbell and P. Emerton (2019) *Emergency Powers in Australia*, Cambridge, Cambridge University Press.

Moore, P. (2001) *Killer Germs: Rogue Diseases of the Twenty-First Century*, London, Carlton Books.

## Journal articles and book chapters

Bennet, B. (2009) 'Legal rights during pandemics: Federalism, rights and public health laws – a view from Australia', *Public Health*, 123(3), pp. 232–236.

Bennett, B., T. Carney and R. Bailey (2012) "Emergency Powers & Pandemics: Federalism and the Management of Public Health Emergencies in Australia", *The University of Tasmania Law Review*, 31(1).

Carney, T., R. Bailey and B. Bennett (2012) 'Pandemic planning as risk management: How fared the Australian federation?', *Journal of Law and Medicine*, 19, pp. 550–568.

Carter, D. (2020) 'The Use Of Coercive Public Health And Human Biosecurity Law In Australia: An Empirical Analysis', *UNSW Law Journal*, 43(1), pp. 117–153.

- Chen, C. (2018) 'Less is more: regulating the weaponization of disease under the National Health Security Act 2007 (Cth)', *Journal of Law and Medicine*, 25(3), pp. 678–691.
- Faunce, T. and S. Durant (2018) 'Analysis of Australia's new Biosecurity Legislation', *Journal of Law and Medicine*, 25, pp. 647–654.
- Gerangelos, P. (2012) 'The Executive Power of the Commonwealth of Australia: Section 61 of the Commonwealth Constitution, 'nationhood' and the Future of the Prerogative', *Oxford University Commonwealth Law Journal*, 12(1), pp. 97–131.
- Golder, B. and G. Williams (2006) 'Balancing the national security and human rights: Assessing the legal response of common law nations to the threat of terrorism', *Journal of Comparative Policy Analysis: Research and Practice*, 8(1), pp. 43–62.
- Gray, A. (2015) 'The Australian quarantine and biosecurity legislation: Constitutionality and critique', *Journal of Law and Medicine*, 22, pp.788–810.
- Greenleaf, G. and K. Kempt (2020) 'Australia's 'COVIDSafe App': An Experiment in Surveillance, Trust and Law', *University of New South Wales Law Research Series*, 999.
- Guy, S. and B. Hocking (2006) 'Times of Pestilence: Would a Bill of Rights Assist Australian Citizens Who Are Quarantined in the Event of an Avian Influenza (Bird Flu) Pandemic?', *Current Issues in Criminal Justice*, 17(3), pp. 451–467.
- Howse, G. (2004) 'Managing emerging infectious diseases: Is a federal system an impediment to effective laws?', *Australia and New Zealand Health Policy*, 1.
- Kunc, Justice F. (2020) "'Federalising" emergencies', *Australian Law Journal*, 94(3), p. 167.
- Larkin, P. and J. Uhr (2009) 'Bipartisanship and Bicameralism in Australia's 'War on Terror': Forcing Limits on the Extension of Executive Power', *The Journal of Legislative Studies*, 15(2–3), pp. 239–256.
- Mueller, S. (2016) 'Turning emergency powers inside out: are extraordinary powers creeping into ordinary legislation?', *Flinders Law Journal*, 18, pp. 295–319.
- Neal, A. (2012) '[Normalization and Legislative Exceptionalism: Counterterrorist Lawmaking and Changing Times of Security Emergencies](#)', *International Political Sociology*, 6.
- O'Brien, I. M. (2007) 'Citizenship, Rights and Emergency Powers in Second World War Australia', *Australian Journal of Politics and History*, 53(2), pp. 207–222.
- Opeskin, B. (1998) 'The Architecture of Public Health Law Reform: Harmonisation of Law in a Federal System', *Melbourne University Law Review*, 22, pp. 342–43.
- Pelkas, C. (2010) '[State Interference with Liberty: The Scope and Accountability of Australian Powers to Detain During a Pandemic](#)', *Flinders Law Journal*, 12(1).
- Reynolds, C. (2004) 'Quarantine in Times of Emergency: The Scope of S 51 (ix) of the Constitution', *Journal of Law and Medicine*, 12(2), pp. 166–77.
- Saunders, C. (2005) '[Intergovernmental agreements and the executive power](#)', *Public Law Review*, 16, pp. 294–313.
- Twomey, A. (2010) 'Pushing the Boundaries of Executive Power - Pape, the Prerogative and Nationhood Powers', *Melbourne University Law Review*, (34)1, pp. 313–343.
- Wilson, K., C. McDougall and R. Upshur (2005) '[The New International Health Regulations and the Federalism Dilemma](#)', *PLoS Med* 3, 1, e1.
- Wilson, K., C. McDougall, D. Fidler and H. Lazar (2008) '[Strategies for Implementing the New International Health Regulations in Federal Countries](#)', *Bulletin of World Health Organisation*, March, 86(3), pp. 215–20.

## Other research

- Brenker, S. (2020) '[An executive grab for power during COVID-19?](#)' *Australian Public Law Online*, 13 May.
- Buchanan, K. (2015) '[Australia: legal responses to health emergencies](#)', *Library of Congress*, online.
- Constitution Education Fund (2020) '[Is cooperative federalism all it's cracked up to be?](#)' CEFA website, 26 March.
- Duckett, S. (2020) '[Coming out of COVID-19 lockdown: the next steps for Australian health care](#)', Melbourne, Grattan Institute.
- Edgar, A. (2020) '[Law-making in a crisis: Commonwealth and NSW coronavirus regulation](#)', *Australian Public Law*, 30 March.
- Elphick, K. (2020) '[Australian COVID-19 response management arrangements: a quick guide](#)', Canberra, Australian Parliamentary Library.
- Elphick, K. (2020) '[Australian pandemic response planning: a quick guide](#)', Canberra, Commonwealth Parliamentary Library.

- Elphick, K. (2020) *National emergency and disaster response arrangements in Australia: a quick guide*, Canberra, Commonwealth Parliamentary Library.
- Evans, K. and N. Petrie (2020) 'COVID-19 and the Australian Human Rights Acts', Australian Public Law, 6 May.
- Grove, A. (2020) *COVID-19 and aged care: a quick guide*, Canberra, Australian Parliamentary Library.
- Huf, B. and H. Mclean (2020) 'Epidemics and pandemics in Victoria: Historical perspectives', *Research Paper*, no. 1, Melbourne, Victorian Parliamentary Library.
- Hughes, G. (2020) 'Privacy Act Amended to Regulate COVIDSafe App Data', *Davies Collison Cave*, 18 May.
- Leins, K., S. Coghlan and M. Cheong (2020) 'Do we really need a tracking app and can we trust it?' *Legal Affairs*, 24 April.
- Maclean, H. and K. Elphick (2020) *COVID-19 Legislative response—Human Biosecurity Emergency Declaration Explainer*, Canberra, Australian Parliamentary Library.
- Petrie, C. (2020) 'Privacy Amendment (Public Health Contact Information) Bill 2020', *Bills Digest*, Canberra, Australian Parliamentary Library.
- Pyburne, P. (2020) 'COVID-19 Economic response- delegation by the Director of Human Biosecurity', *FlagPost*, Australian Parliamentary Library.
- Scully, S. (2009) *Does the Commonwealth have constitutional power to take over the administration of public hospitals*, Canberra, Australian Parliamentary Library.
- Smith, S. (2020) 'The Scope of a Nationhood Power to Respond to COVID-19: Unanswered Questions', *Australian Public Law*, 13 May.

## Websites

- AMA and Law Council of Victoria (2020) 'COVID-19: Rights and responsibilities under the Biosecurity Act', Fact Sheet, AMA website.
- Amnesty International Australia (2020) 'Email Minister Roberts: Make sure the COVID-19 app respects human rights', website.
- Commonwealth Department of Health (2020) *Australian Health Protection Principal Committee (AHPPC)*, website.
- COVID-19 Law monitor (2020) 'New and Amended Commonwealth Laws', website.
- Department of Health (2020) 'State quarantine requirements for interstate travel', website.
- Department of Health and Human Services (2020) 'Coronavirus (COVID-19) Information', website.
- Department of Health and Human Services (2020) 'Stay at home – restricted postcodes', website.
- Department of Home Affairs (2020) 'National Coordination Mechanism', website.
- Emergency Management Victoria (2019) 'State emergency plans', website.
- Emergency Management Victoria (2020) *State Control Centre (SCC)*, website.
- Justice Connect (2020) 'How the Victorian Government's Emergency Restrictions on COVID-19 (Coronavirus) work', website.
- Liberty Victoria (2020) 'COVID-19 and human rights', website.
- Practical Law Australia (2020) 'COVID-19: Federal government powers and planning', website.
- Special Commission of Inquiry into the Ruby Princess (2020) 'Terms of reference', website.

# Research & Inquiries Service

---

Research papers are produced by the Library's Research & Inquiries service. They provide in-depth coverage and detailed analysis of topics of interest to Members of Parliament. Research publications are prepared for Parliament in response to Members, and in anticipation of their requirements, in areas of interest to the Victorian legislature.

Information in this paper was current as at the time of printing. It should not be considered as a complete guide to the particular subject or legislation covered. While it is intended that all information provided is accurate, it does not represent professional legal opinion. Any views expressed are those of the author(s).

Some hyperlinks may only be accessible on the Parliament of Victoria's intranet. All links are current and available as at the time of publication.

## **Enquiries:**

Coordinator, Research & Inquiries  
Victorian Parliamentary Library & Information Service  
Parliament House  
Spring Street, Melbourne  
Telephone (03) 9651 8640  
[www.parliament.vic.gov.au](http://www.parliament.vic.gov.au)