

[54] ELECTRICAL HEATING APPARATUS FOR GENERATING SUPERHEATED VAPORS

605,089 7/1948 Great Britain 219/373

[76] Inventor: Dale L. McAlister, 4314 Jefferson, Midland, Mich. 48640

Primary Examiner—A. Bartis
Attorney, Agent, or Firm—Glwynn R. Baker

[22] Filed: Sept. 17, 1973

[21] Appl. No.: 398,047

[52] U.S. Cl. 219/300, 219/275, 219/373, 222/146 HE, 239/133, 239/136

[51] Int. Cl. H05b 3/42, B05b 1/24, F22g 1/16

[58] Field of Search 219/271-276, 219/300, 373; 239/133-136; 222/146 R, 146 HE

[57] ABSTRACT

An improved apparatus for generating superheated vapors of vaporizable organic liquids having a novel superheating section capable of delivering a wide swath of superheated vapors. The new section is substantially a loop of electrical resistance tubing connected to the vapor generating section of a mobile or hand-held electrical resistance tube heater. The loop is hollow through about two-thirds of its length, the remainder, the return to the electrical circuit, being solid. The tubular portion of the superheater has a plurality of perforations in a substantially straight section, which section is surrounded by a slotted housing for directing the vapors entering the housing from the perforated tube.

[56] References Cited
UNITED STATES PATENTS

912,994	2/1909	Conrad	219/300
1,286,512	12/1918	Bintliff	219/300
1,403,594	1/1922	Duo	219/300
2,109,900	3/1938	Cohen	219/300
2,287,974	6/1942	Cohen	219/300 X
3,234,357	2/1966	Suethé	219/300 X

FOREIGN PATENTS OR APPLICATIONS

482,715	4/1938	Great Britain	219/300
---------	--------	---------------------	---------

1 Claim, 1 Drawing Figure

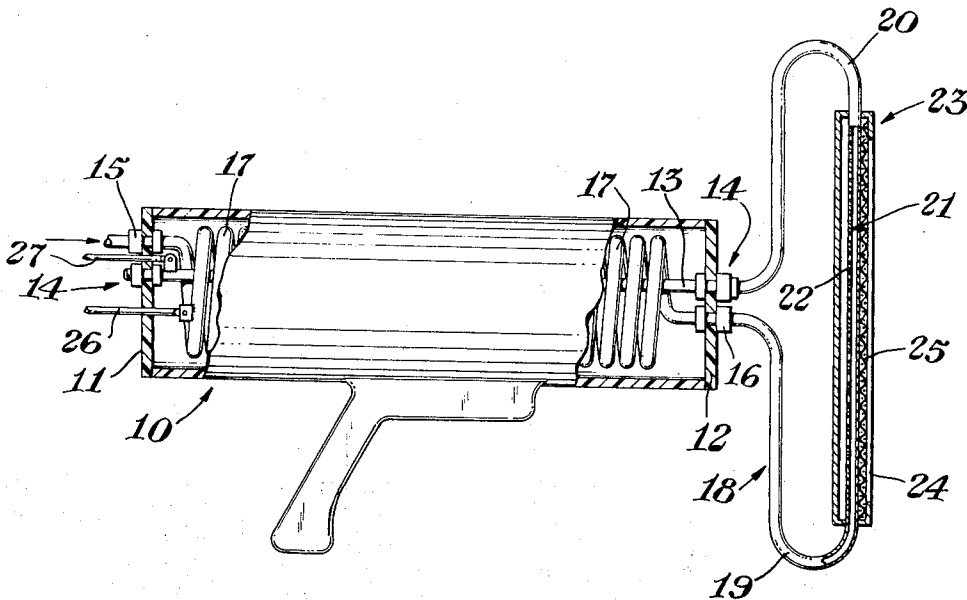

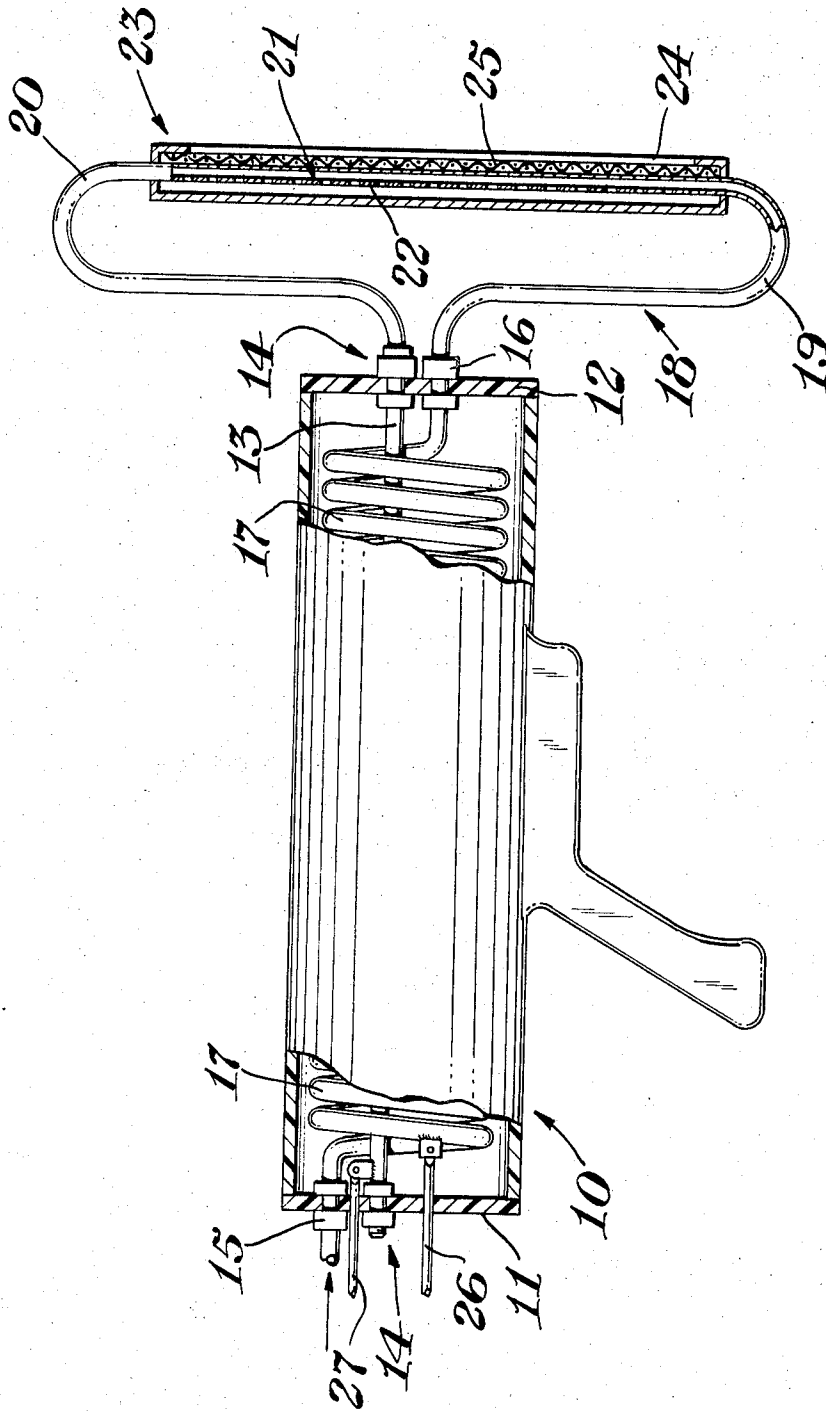

ELECTRICAL HEATING APPARATUS FOR GENERATING SUPERHEATED VAPORS

BRIEF DESCRIPTION OF THE INVENTION

An improved apparatus for generating superheated vapors of chlorinated hydrocarbon based vapor reflow compositions comprised of a hand-held body in which is positioned a tubular resistance coil and its associated wiring to energize the coil. The coil is connected to an exterior spray-superheater which is shaped much in the nature of an oblong single coil. The coil is tubular through about three-fourths of its length and is completed with a return to the housing by an electrical conductive solid rod. The straight length of the coil is perforated on the housing side. A chamber surrounds the coil and is provided with a slit or window 180° from the perforate side of the coil. The window may be provided with a screen to assist in diffusion and uniformity of pattern of the superheated vapors. The window may also be provided with a closure means to permit adjustment of the window size.

BRIEF DESCRIPTION OF THE DRAWING

The sole FIGURE of the drawing is a view, partially in section, showing an embodiment of the apparatus of the invention.

DETAILED DESCRIPTION OF THE INVENTION

One embodiment of the apparatus of the present invention is illustrated in the drawing. In this embodiment, the apparatus consists of an electrical and heat insulating shield member 10 of generally cylindrical shape closed at each end with caps 11 and 12, respectively. The end caps 11 and 12 are preferably retained in their respective positions by a rod 13 axially located between the ends. Each end of rod 13 is threaded and a pair of nuts 14 screwed thereon, one on each side of the respective cap, thus retaining and spacing the end caps in fixed, but removable position, on shield 10. One end cap 11 has two holes through it to enable an electrical cable to be passed into the interior of shield 10. Each end cap 11 and 12 also is provided with a threaded adaptor or connector tube 15 and 16 providing a passage through the end caps and a means for connecting tubular fluid carrying tubes through the end caps. Connector 15 exterior of the end cap 11 is connected to a tube or hose which is connected to a source of fluid (not shown). Interior of end cap 11, connector 15 is connected to a tubular electrical resistance ele-

ment 17 which is illustrated in coil form. The other end of coil 17 is connected to the interior portion of connector 16. Exterior of connector 16 is a loop 18, a part of which is tubular electrical resistance element 19 and a portion of which is a solid electrical conductor 20 which connects the tubular portion 19 of the loop 18 to the conductor rod 13. The tubular portion 19 of the loop 18 has a section of substantially straight configuration 21 which perforated on the rear side 22. A housing 23 surrounds the straight portion 21. The housing is provided with a slot 24 along its length which is positioned on the opposite side of tubular section 21, thus providing an access to the atmosphere of vapors exiting perforate tube 21 into housing 23. The slot 24 may be covered with a fine mesh screen 25 as illustrated to assist in the distribution of the vapors.

Electrical cables 26 and 27 are provided from a source of electrical energy (not shown) connected one to each interior end of rod 13 and heating element 17.

Control means (not shown) may be secured to the handle or to a remote control panel for controlling both the flow of fluid and electrical current to the apparatus.

I claim:

1. An apparatus for generating superheated vapors from liquid compositions based on a poorly conductive organic liquid which comprises:

- a. a tubular electrical resistance heater coil having an inlet end and an outlet end,
- b. a shield around said heater coil,
- c. a handle for said shield,
- d. a superheater element of electrical resistance material, electrically and fluidly connected to the outlet end of said coil,

said superheater element being tubular through a major portion of its length and provided with a straight section which is at right angles to the axis of the heater coil and which straight section is perforated along its length on the side nearest the shield, said perforated tubular section being surrounded by a housing having a longitudinal slot in indirect communication about 180° from said perforations, said tubular portion of said superheater terminating in a solid electrical conductor returning to said shield for completion of the electrical circuit and for positioning said superheater element with respect to said shield.

* * * * *

50

55

60

65