

NEXUS

NEW TIMES MAGAZINE

Volume 4, Number 3 APRIL - MAY 1997

PO Box 30, Mapleton Qld 4560, Australia

CONTENTS

LETTERS TO THE EDITOR.....	4	TREASURE TROVE OF THE KNIGHTS TEMPLARS.....	61
GLOBAL NEWS.....	6	<i>By André Douzet. The mysterious Order of the Knights Templars may have resurrected itself in recent times, but will its legacy of documents and sacred artefacts ever be made public?</i>	
ALONG CAME THE TRANSNATIONALS.....	13	THE TWILIGHT ZONE.....	67
<i>By Daniel Brandt. In their relentless pursuit of power and profit, the transnational corporations of today are debasing the social and economic fabric of cultures worldwide.</i>		<i>Strange tales from around/within/off the world, including a new letter from an ex-Vatican priest concerning Comet Hale-Bopp; and Kris Sherwood's story of marine lightwheels, crop circles of the sea.</i>	
SOYBEAN PRODUCTS: A RECIPE FOR DISASTER?...	19	STRANGE TALES ABOUT SEA SERPENTS.....	73
<i>By Joseph G. Hattersley. According to medical research, soybean-based products can have harmful effects on health. Their place in our diets should be seriously reconsidered.</i>		<i>By C. D. Pollard. So many eyewitness accounts of 'sea serpents' through the centuries can't all be figments of the imagination. Perhaps the plesiosaur has indeed survived the age of the dinosaurs.</i>	
THE PEGASUS FILE—Part 1.....	25	REVIEWS—Books.....	79
<i>By David G. Guyatt. At great risk to self and family, ex-CIA deep-cover agent Chip Tatum has gone public with his disturbing revelations about the "Boss Hogs" who control the global drug trade.</i>		<i>"Paradigm Wars" by Mark B. Woodhouse</i>	
THE LIVING WATER OF JOHANN GRANDER.....	35	<i>"CoEvolution" by Alec Newald</i>	
<i>By Jill Fraser. Our water should be full of life-force, but so often it contains health-depleting energies. Thanks to Austrian naturalist Johann Grander, there is now a way to restore water's essential vitality.</i>		<i>"The Octopus" by Kenn Thomas and Jim Keith</i>	
SOUND TECHNIQUES TO TUNE YOUR HEALTH.....	41	<i>"On the Track of Water's Secret" by H. Kronberger & S. Lattacher</i>	
<i>By Sharry Edwards. Like a musical instrument, the body needs tuning for optimum operation. Sound therapies such as BioAcoustics and the Tomatis Method can help harmonise our energy patterns.</i>		<i>"When the Comet Runs" by Tom Kay</i>	
NEW SCIENCE NEWS.....	47	<i>"Wizard: The Life and Times of Nikola Tesla" by Marc J. Siefer</i>	
<i>A selection of interesting news and views from the underground science network. This issue, we feature Martin Gottschall's speculations on the recent Finnish breakthrough in artificial gravity.</i>		<i>"Mystery Cities of the Maya" by Thomas Gann</i>	
BRIGHT SKIES—Part 1.....	53	<i>"Healing Sounds: The Power of Harmonics" by Jonathan Goldman</i>	
<i>By Harry Mason. Explosive fireball events over the Australian outback are more likely the result of foreign military EM weapons tests than of meteors. Stranger still, they may even involve cults or UFOs.</i>		<i>"Beloved Visitors" by Cherie Sutherland, Ph.D.</i>	
		<i>"Design Ecology" by Michael Riversong</i>	
		<i>"Tooth Truth" by Frank J. Jerome, D.D.S.</i>	
		<i>"Pyramid Power: The Millennium Science" by Dr G. Pat Flanagan</i>	
		<i>"UFOs and Anti-gravity: Piece for a Jig-Saw" by Leonard G. Cramp</i>	
		<i>"Skywatchers, Shamans & Kings" by E. C. Krupp</i>	
		<i>"The Poltergeist Machine: The Hutchison Effect" by Albert Budden</i>	
		<i>"Witnessed" by Budd Hopkins</i>	
		REVIEWS—Video.....	86
		<i>"Jurassic Art" from The Mysterious Origins of Man Series</i>	
		<i>"The Quest for Knowledge Series"</i>	
		REVIEWS—Audio.....	87
		<i>"Windjana" by Tony O'Connor</i>	
		<i>"My People" by Joe Zawinul</i>	
		<i>"Preludes, Airs & Yodels" by Penguin Cafe Orchestra</i>	
		<i>"Flamenco Falsetas" by Dickson & Martinez</i>	
		<i>"Wandjina: Dancing the Dreamtime" by 93-D</i>	
		NEXUS BOOKS, SUBS, ADS & VIDEOS.....	98

NEXUS MAGAZINE

Volume 4, Number 3

APRIL - MAY 1997

PUBLISHED BY

NEXUS Magazine Pty Ltd, ACN #003 611 434

EDITOR

Duncan M. Roads

CO-EDITOR

Catherine Simons

ASSISTANT EDITOR

Ruth Parnell

EDITORS' ASSISTANT

Richard Giles

OFFICE ADMINISTRATOR

Janine Carmichael

CONTRIBUTORS THIS ISSUE

Daniel Brandt, Joseph G. Hattersley,
David G. Guyatt, Jill Fraser, Sharry Edwards,
Martin Gottschall, Harry Mason, André Douzet,
Filip Coppens, Kris Sherwood, C. D. Pollard

LAYOUT & DESIGN

Duncan M. Roads

CARTOONS

Phil Somerville

COVER GRAPHIC

David Rickerd/The Image Bank

PRINTING

Warwick Daily News, Queensland, Australia

AUSTRALIAN DISTRIBUTION

Newsagents Direct Distribution

HEAD OFFICE - All Correspondence

PO Box 30, Mapleton, Qld 4560, Australia.

Ph: +61 (0)7 5442 9280; Fax: +61 (0)7 5442 9381

e-mail address: nexus@peg.apc.org

web page: <http://www.peg.apc.org/~nexus/>

NEW ZEALAND OFFICE

PO Box 34735,

Birkenhead, Auckland. Ph: +64 (0)9 416 7320;

Fax: +64 (0)9 416 7340

USA OFFICE

PO Box 177, Kempton, IL 60946-

0177. Ph: (815) 253 6464; Fax: (815) 253 6454

UK OFFICE

55 Queens Rd, East Grinstead, West

Sussex, RH19 1BG. Ph: +44 (0)1342 322854;

Fax: +44 (0)1342 324574

EUROPE OFFICE

PO Box 372, 8250 AJ Dronten,

The Netherlands. Ph: +31 (0)321 380558;

Fax: +31 (0)321 318892

ITALY OFFICE

c/- Avalon Edizioni, Piazza

Mazzini 52, 35137 Padova.

Ph/Fax: +39 (0)49 912 6006

STATEMENT OF PURPOSE

NEXUS recognises that humanity is undergoing a massive transformation. With this in mind, NEXUS seeks to provide 'hard-to-get' information so as to assist people through these changes.

NEXUS is not linked to any religious, philosophical or political ideology or organisation.

PERMISSION-TO-REPRODUCE POLICY

While reproduction and dissemination of the information in NEXUS is actively encouraged, anyone caught making a buck out of it, without our express permission, will be in trouble when we catch them!

Editorial

Amongst the more controversial articles we have published is one on the subject of urine therapy. Now before you non-believers 'switch off', I want to convey to you my amazement at how many people are phoning or writing in with amazing results—especially with melanoma/skin cancer/mole removal. If you want the actual details on what to do, refer to Letters to the Editor this issue.

I would now like to give some feedback on how I see readers grouped according to two main categories:

a) Readers who pretty much assume that what is in NEXUS is true, and don't bother to check before they try out something they learned from NEXUS.

b) Readers who use the info in NEXUS as a 'prompt' to find out further how various bits of information can be used to benefit them, or whether they should reject it entirely from their view of reality.

Readers in the first category can be a challenge to themselves and others. These people are prone to trying out new health treatments without knowing why; or are likely to regurgitate something they half-remember from NEXUS to someone mildly sceptical—and thus ruin both their and our reputation.

Readers in the second category tend to follow up on items that amuse, inspire or challenge them, to find out how to use this information to improve the quality of their lives. More importantly, they do not rush blindly into things.

My point here relates more to the health articles raised in NEXUS. We have published a lot of material outlining often successful alternative approaches to disease. Obviously, many of our readers have experimented on themselves, or their friends and relatives, with varied results. While I am happy to see INFORMED experimentation, I am unhappy to hear of people rushing blindly into a treatment situation without taking the time to find out the basics of what is happening and why.

It thus leads me to the big point here: sickness and ill health should be viewed as an OPPORTUNITY rather than a setback. When you are sick, it is time to learn about your body, your health and the health-care alternatives facing you.

We strive to present you with alternatives that you would not normally be exposed to via the 'normal' media. Please take these as opportunities to learn more about maintaining good health, and not just physical health, either. Health is important, but it is unwise to give away to other people the power of decision-making regarding what goes into your body to make it healthy. This is the information age, if nothing else. Empower yourselves with the information available, but do not rush off using urine or zappers to cure just anything. Most importantly, you should identify what has caused the problem, then fix that, and fix the rest after that.

Oh dear, I've already raved myself right to the end of this Editorial. You have been spared much more, but it can wait 'til next issue.

Meanwhile, enjoy your reading.

Duncan

WARRANTY AND INDEMNITY

Advertisers upon and by lodging material with the Publisher for publication or authorising or approving of the publication of any material INDEMNIFY the Publisher and its servants and agents against all liability claims or proceedings whatsoever arising from the publication and without limiting the generality of the foregoing to indemnify each of them in relation to defamation, slander of title, breach of copyright, infringement of trademarks or names of publication titles, unfair competition or trade practices, royalties or violation of rights or privacy AND WARRANT that the material complies with all relevant laws and regulations and that its publication will not give rise to any rights against or liabilities in the Publisher, its servants or agents and in particular that nothing therein is capable of being misleading or deceptive or otherwise in breach of the Part V of the Trade Practices Act 1974. All expressions of opinion are published on the basis that they are not to be regarded as expressing the opinion of the Publisher or its servants or agents. Editorial advice is not specific and readers are advised to seek professional help for individual problems.

© NEXUS New Times 1997

Letters to the Editor ...

Moon Photos Cover-up?

Dear Duncan: It was interesting reading the article (NEXUS 2#28) on possible artifacts on the Moon. I was enthralled by the prospects of the remains of an ancient Earth civilization maybe millions of years old, but I admit I was skeptical due to the very tenuous evidence supporting the theory.

However, the article wet my appetite for similar information, and I obtained a copy of the *Hoagland's Mars Vol. III* video which supports similar theories. In his videotaped lectures Hoagland presents evidence from greatly enlarged images taken from early Moon probes that were sent to take surveillance photos before crashing on the Moon, in preparation for the *Apollo* program. These images seemed to show the remains of a super structure that once may have supported vast glass domes miles wide covering entire lunar craters.

My thirst for more information grew as did my level of skepticism. Then I heard about the *Clementine* Moon probe, a military probe sent a few of years ago to provide more detailed images of the Moon.

We all know about spy satellites that from Earth orbit can resolve objects as small as 5 inches through the Earth's atmosphere. Therefore it seems reasonable the *Clementine* would beam back images with a resolution perhaps of 2 inches due to the vacuum of space. I eagerly awaited the *Clementine* images. But alas, when the images were published (Internet users see <http://clementine.cnes.fr/index.en.html>), only images with a resolution of hundreds of meters were presented. Now I am not so skeptical.

Do they honestly believe that we would believe that with all the modern satellite imaging technology they would only equip *Clementine* with 1960s technology? What's going on? I want to see the real images.

All this makes you wonder why apparently the space shuttle can't leave Earth orbit to explore the Moon—strange. Are they worried that new/ancient technology perhaps found underground on the Moon will weaken our dependence on fossil fuel? Are they worried that if the world was united and made a good and happy place it would weaken our 'depen-

dence' on arms technology? All this is of course conjecture, but the *Clementine* affair only makes me wonder.

David D., Buderim, Queensland, Australia.

Do-it-Yourself Urine Cures

No. 1—Dear Duncan: When you used the valuable pages of NEXUS to expound on the "Hollow Earth Theory", I really thought you guys were losing it. Then, when you printed all that stuff on "Urine Therapy", I nearly cancelled my subscription. I mean, come on, I thought, you'd have to be utterly desperate even to try it.

Well, after thirty years of suffering virtually every gastro-related illness there is, I was! I did! And swat me with a stained glass window, it works! My haemorrhoids were the first positive sign: they went in the first week!

Now, three months later, I am the healthiest man that I can remember being, so allow me to sincerely thank all of you at NEXUS for the ultimate gift, my health (though I still don't buy all this Hollow Earth nonsense!).

Regards, Robert J. H., North Arm, Queensland, Australia.

No. 2—Duncan: Your information on urine therapy (NEXUS 3#02) inspired a little experiment this summer.

I've had a large, 15-mm diameter, dark, irregularly shaped and chunky mole in the middle of my chest for 20 years. Doctors checked it a few years ago and gave it a clean bill of health. This year it became scratchy. After reading in NEXUS how skin cancer can melt away through prolonged exposure to the patient's own urine, I wondered how my 20-year-old mole would react. After 10 days it deflated and virtually disappeared.

The fun part was devising a system that prevented any contact, smell or discomfort to myself or friends throughout the course, while keeping the test area saturated 24 hours a day. Here's how.

Cut a square patch of body tape, large enough to cover the mole (or cancer). (Lay it on a table, sticky side up.) Before applying it, place a thick ball of cotton wool central on the sticky side of the tape. Press your cotton wool-filled plaster onto the mole but press only

three sides of the plaster onto your skin. (left, bottom, right) Leave the top open. (But *first*, shave if you have a hairy chest, for reasons that will become apparent later.)

In the morning, pee into a specimen jar. With practice you should aim to capture only a small amount of your midstream urine. Cap it. (Wash if you missed.) Use a hospital syringe, without the needle, to extract an amount that the cotton wool can comfortably hold. In my case, 10 ml worked fine. (Too much will drip, too little is too dry.) Slowly inject this specimen into the cotton wool through the top of your plaster which you left open. Done!

You'll be surprised at the lack of smell but, if you feel self-conscious, a small spray of cologne will do the trick.

Wash the syringe. Reapply from the original specimen as needed to keep the cotton moist. Only twice a day worked fine for me. After three days it began melting away. Just goes to show, if you piss on anything long enough it'll go away, unless it's genetically supposed to be there.

Mike S., Flux Research, NSW, Australia.

(Dear Robert & Mike: The feedback from readers who've tried urine therapy has been absolutely amazing! All sorts of problems have been cleared up—skin cancer being the most commonly reported. Yes, urine applied externally to skin cancers knocks 'em dead, according to about two dozen individual reports to our office alone! Go for it, readers! Ed.)

Not Content with Cover-ups!

I consider NEXUS to be the best of all the lunatic fringe mags I've encountered. This includes quality of writing and editing, which is not to say that it's perfect, but in a dismal field you're better than most. Probably because you weren't 'educated' in the US.

My main request is that you keep publishing stuff that is in totally new fields. You say you have a huge backlog of stuff that you don't have room for. Of course, some perennial favorites like crop circles and ETs are always going to get their due, but a lot of the same old stuff does not need to be represented every issue.

I'm particularly bored with more and more details about how the CIA, the DEA, the NSA and all

the other assholes are importing drugs, killing people, subverting governments and doing all the shit that we know they always do.

I'm much more interested in stuff that I can do in my life to help generate the new frequency of reality that we all think is in the process of emerging.

Of course, it's good to warn people about the latest scams that are supposed to suck us into becoming more compliant robo-slaves, but interminable lists of evil deeds and conspiracy genealogies serve basically no purpose, in my opinion. What the hell am I going to do with this information?

Same goes for UFO sighting cover-up 'scandals'. This shit is no longer news! Let's hear more from people who have talked with these beings, who have interesting speculations about who and what they might actually be and what the hell they're up to. Obviously, they don't all have the same agenda—so let's hear about that.

I would also love to see one new science article about a free-energy device that actually works! Every article is the same: grandiose proclamations about unlocking the secrets of the Universe; horrifically explained technical details; account of building, or trying to build, the holy object; conclusion paragraph admitting that the thing generated about a tenth of a picowatt of a milli-ampere of a microwatt of 'free energy'; or that they didn't have enough money to get it together; or t

hat no one's ever been able to duplicate Tesla's shit anyway...

Overall, though, I give you an A minus. Excellent diversity, pretty good editorial quality, fascinating advertising and, most important, heart's in the right place. Bravo!

Ethan C., Berkeley, CA, USA.

(Dear Ethan: I agree with most of your points, except those about free-energy research. I don't feel we hype it up as much as you suggest, and I do believe that one day such cross-pollination of research will help make the 'big one' available. Ed.)

Making the Right Choices

Dear Duncan: I would take this opportunity to comment on the Editorial which appeared in February/March 1997 issue of NEXUS (4#02).

I was pleased to read what may be considered NEXUS policy, and

... more Letters to the Editor

NB: Please keep letters to approx. 100-150 words in length. Ed.

one which does not pander to the needs of sales, but expresses a powerful message to the readers as to how an individual must take responsibility on all levels of living, beginning with the here and now.

Yes, everyone does have a choice and should use it wisely, for that is the only way that we will see predictable Earth Changes.

In the book, *One Light*, the Transmissions of Zadore consistently exposed the illusion in which we live, and which is propped up by those Entities outlined in your Editorial.

All we need to do is to want to do something, something in a positive manner to assert our freedom, and what better way than to make the right choices, those being the right choices for our Earth.

It is the beginning of true self-empowerment.

Douglas Jesse, Launceston, Tasmania, Australia.

Mother Shipton Prediction

Dear NEXUS: Congratulations on what I believe to be the best magazine in your field! I have collected every copy for the last five years, and am happy to enclose a subscription renewal.

I would also like to bring to your attention something I have discovered, and wonder if you or your readers are aware of the connection between one of the predictions of Mother Shipton and recent events unfolding in and around Mexico City.

NEXUS vol. 2, no. 24 has some very interesting predictions from Mother Shipton which, I believe, could be referring to the present times. In particular, I quote the lines:

*Three sleeping mountains
gather breath;
And spew out mud, and ice
and death.*

There is only one place in the world I know of that could fit this prophecy, and it lies in Mexico—the scene of the largest ongoing UFO flap ever. The key was "sleeping mountains".

If we assume that a sleeping mountain is a volcano, we have, between Mexico City and Pueblo, Mt Popocatepetl, Mt Ixtacihuatl and, east of Pueblo, Mt Citlaltépetl. Translated into English we have: Popocatepetl,

"Sleeping Warrior"; Ixtacihuatl, "Sleeping Woman"; Citlaltépetl, "Sleeping Sentinel".

Today they are no longer sleeping. Popocatepetl has been venting for around four years now, after being dormant for hundreds of years.

Mother Shipton also mentions other signs to watch out for "as man nears latter century". She mentions the coming of a "fiery Dragon", interpreted by most to be a comet.

We live in interesting times and I believe we are about to witness things beyond our imagination. I look forward to reading about them in future issues of NEXUS.

Yours truly, N.J.M., Traralgon, Victoria, Australia.

Acclaim for Colloidal Silver

Dear Editor: In a previous issue regarding an article on Colloidal Silver, you asked for feedback.

Well, I contacted Mr Courtenay of Montville (whose name may well be Courtly, as he was so kindly spoken) on Dec. 13, and he despatched a 300ml bottle immediately (without waiting for payment or anything). I received the package on Dec. 16 and began application immediately on a most horrible gum infection (which I did not have until some very inept dental work) and also ingested the recommended amount.

The results were marvellous. An abscess which had formed, subsided and healed perfectly. I intend to stay with colloidal silver as an immune booster, etc...

Believe me, I would now be toothless in Currumbin if it weren't for colloidal silver...

Lilian T., Currumbin, Qld, Australia.

Alien Communication

Dear NEXUS: The incident of unexplained radio signals from outer space in 1928 was not 'kept secret', as written in NEXUS Feb/Mar '97, but reported in a letter to the scientific journal *Nature* (no. 3079, issue 122/681) in the same year, bearing the title, "Shortwave Echoes and the Aurora Borealis" by Carl Stoermer.

I first read about this astonishing example of communication with an alien technology in Paul Watzlawick's classic *How Real Is Real?*, which I recommend to all

people embarked on the search for truth.

An interesting detail that was left out in your article, is that in the star constellation map obtained by Duncan Lunan, by applying simple geometry, the central star of Bootes, Epsilon Bootis, is grossly displaced. Not in a random way, though, but mirrored precisely along a vertical axis that is an integral part of the message!

Now it has been suggested that to resume the dialogue, we should send out the original message (dating back to 1928), but with Epsilon Bootes in its correct position... This seems like an easy thing to do, yet I have never heard of any progress in this matter. Do any NEXUS readers know more about this?

Yours sincerely, Philip S., London, UK.

In Praise of Sound Therapy

Dear Duncan: My main reason for writing is because when I read the article on Sound and Health in NEXUS 4#01, I knew that I had to make sure you were aware of Sharry Edwards and her 'magical' work with sound!

I studied operatic singing in the late '60s/early '70s, and having always been active in alternative health and libertarian movements I studied all the info I could find on sound and healing. I read the books, took the classes (many of them too 'cutesy' to go into) and even studied Overtone Chanting with Jill Purce on one of her trips to the States.

My hubris was disgusting: I thought I knew it all, and when I came across Sharry Edwards at a Whole Life Conference in New York I didn't bother attending her lecture, assuming that she was going 'to teach me how to hum'. Then, a few months later I attended a Global Sciences Congress in Virginia and, having an hour to kill between lecturers I wanted to hear, I decided to ("What the heck!") listen to the Sound Lady. Five minutes into her lecture I was physically kicking myself and 'mea culpa-ing' my pride. This woman was light years ahead of me and everyone else. One month later, I flew out to Ohio to learn more.

Sharry took Einstein's "mass is energy, energy is mass" to heart and studied the energies—the frequencies—of which we consist.

Over the past several decades, she has been able to determine how to feed different people the different frequencies that they need to reharmonize, or heal, their bodies. I have watched as a paralysed man opened a twisted hand after only twenty minutes of a very specific frequency. I have met a ten-year-old child who weighed 40 pounds, was a sickly shade of blue and was waiting in intensive care for a heart transplant when Sharry got to him. Four months later, he was back at home, a healthy shade of pinky beige and weighing 80 pounds, still healing, but with his old heart ticking just fine. I have met a person who was dying of emphysema. Today he is back at work running his business, golfing on weekends, and, yes, regrowing lung tissue—with frequency.

Last week an emergency came to my door: a young man with rope burns around his neck, who was crying hysterically and suicidal because his wife had left him. I tested his voice and found that her birth sound (yes, we each have a set of birth frequencies!) was missing from his spectrum. You need a balanced spectrum to be mentally, physically and emotionally 'harmonised'. We are attracted to people who have sounds we need and repelled from people who have sounds of which we have too much. I 'fed' this young man the frequency he was missing and within thirty minutes his whole demeanor and attitude changed. He was no longer 'desperate' for his wife's company and he could discuss the situation rationally and logically.

With Sharry's work, I can measure the way a person is using a substance (Is that prescription working for you?), find nutritional deficiencies and toxins, feed them the energy they need to mend their own body parts, discover the root cause of a problem, and on and on. The potential benefits of this work seem endless (anyone want to heat a room with sound?). I am still learning the principles that Sharry has been developing and working successfully with for years...

Keep up the wonderful work. We do look forward to each issue. For Harmony, Kathy Green Fucetola, Life Spirit Center, Newton, NJ, USA.

(Dear Kathy: As you can see, there's an article on Sharry in this issue. Thank you anyway. Ed.)

MOBILE PHONES AS TRACKING DEVICES

Readers of NEXUS will remember a letter to the Editor some issues ago (3#02), where a British motorist reported an accident whilst driving along a motorway. He was surprised to be mildly reprimanded for driving while using the phone, but even more surprised that the emergency operator could tell *who* he was and *where* he was at that point in time, because he was using his mobile phone.

This issue has since made the news in Australia, when New South Wales Privacy Commission chairman Chris Puplick claimed that telephone companies' ability to track customers through their mobile phones was open to abuse under current privacy laws. He also claimed that telecommunications companies (or computer hackers) could keep tabs on mobile phone users via a signal emitted every 30 minutes from their phones, as long as the phone was turned on.

A Telstra spokesman confirmed that mobile phones send a signal to the nearest cell station every half hour, allowing phone companies to determine the location of a customer to the nearest ground cell base. The signal was sent regardless of whether a call was being made, the spokesman said.



According to the *Sydney Morning Herald*, police have been using mobile phone records, kept by Telstra and Optus for billing purposes, to check the alibis of murder suspects and to establish whom drug dealers are calling.

Both Telstra and Optus have confirmed that they keep these records—which give the date, time, cell area from which a call is made, and its destination—for seven years.

(Sources: *Sunshine Coast Daily*, 11 January 1997; *The West Australian*, 4 February 1997; *The Sydney Morning Herald*, 10 February 1997)

GLOBAL BIRTH RATE SLOWDOWN

The world's population will peak at about 10.6 billion in 2080 and then decline, according to a report published last October. One of the main reasons for this slowdown is that the birth rate worldwide is falling faster than expected.

These findings are from the most sophisticated assessment yet of the world's population changes. Published by Earthscan, the survey, titled "The Future Population of the World: What Can We Assume Today?", predicts that the population, which in 1995 was 5.8 billion, will never go higher than 10.6 billion. By the end of the 21st century it will be 10.35 billion.

The UN Population Division's latest biennial analysis also reveals that the growth of the world's population has slowed dramatically and unexpectedly.

According to the report, India will pass China to become the world's most populous nation with 1.6 billion people by 2050.

It also reports that a population landmark was reached in 1996. Africa's population is believed to have exceeded Europe's for the first time in recorded history.

"Nigeria alone will have twice the population of western Europe by 2050, at around 350 million", says Gerhard Heilig of the International Institute for Applied Systems Analysis, based in Austria.

(Sources: *New Scientist*, 14 December 1996; *Sydney Morning Herald*, 9 October 1996)

ADL TACTICS EXPOSED BY NOAM CHOMSKY

"In the United States, a rather effective system of intimidation has been developed to silence critique. Let me give you just one example. Take the Anti-Defamation League (ADL), the B'nai B'rith, which is reputed to be a civil rights organisation.

"It's rather comical. It's actually an organisation which is devoted to trying to defame and intimidate and silence people who criticise current Israeli policies, whatever they may be.

"For example, I, myself, through a leak in the New England office of the ADL, was able to obtain a copy of my file there. It's 150 pages, just like an FBI file—interoffice memos warning that I'm going

God's computer

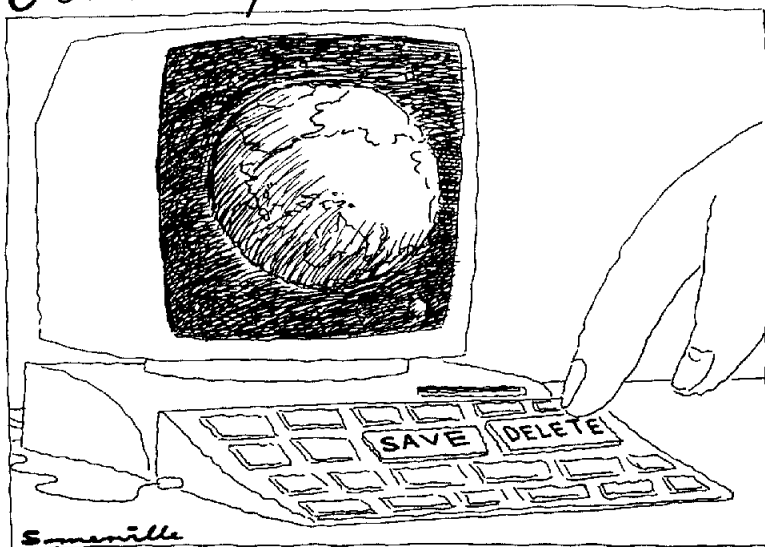

... GLOBAL NEWS ...

to show up here and there, surveillance of talks that I give, comments and alleged transcripts of talks, of the sort that you'd expect—mostly fabricated because people don't hear or can't understand. This material has been circulated. If I'm going to give a talk somewhere—if I came out to Boulder [Colorado] to give a talk—this material would be sent to some local group which would use it to extract defamatory material which would then be circulated, usually in unsigned pamphlets outside the place where I'd be speaking.

"I happened to get this material when it was being sent to a Harvard law professor named Alan Dershowitz in preparation for a debate that we were to have a few days later, so that he would be able to extract from it defamatory material concocted by the ADL surveillance system, which is in fact exactly what he did.

"This is typical of the way they act. If there's any comment in the press which they regard as insufficiently subservient to the party line, there'll be a flood of letters, delegations, protests, threats to withdraw advertising, etc."

(Source: C. P. Otero, *Language and Politics* [Black Rose Books, 1988, p. 642], a book of interviews with Prof. Noam Chomsky)

ASSAULT BY VACCINES

Harris Coulter, author of *Vaccination, Social Violence and Criminality: the Medical Assault on the American Brain*, has found in his research into autism that vaccines have been known to cause encephalitis since 1922, when such an outbreak occurred as a result of the smallpox vaccine. The diphtheria, tetanus and pertussis vaccines followed in 1925.

An article in *Pediatrics Journal* (vol. 39, 1967) suggests it is highly probable that autoimmune and developmental disabilities are interlinked by vaccine-induced encephalitis.

Since 1959 it has been known that the pertussis vaccine (the 'P' in DPT) can cause allergic encephalomyelitis. Scientists who were conducting experiments on lab animals, with the purpose of inducing anaphylactic shock, found it to be extremely effective.

According to the US Department of Health and Human Services, an estimated 60,000 DPT shots annually are reported as having been followed by convulsions, shock, collapse, temperatures of 105

degrees and/or high-pitched screaming. Children who do not survive are often labelled SIDS babies, even if they die on the same day of the shot. One out of 750 children who receives all of their DPT shots is left severely injured. At least 12,000 others are clinically diagnosed as having been severely damaged by vaccinations, yet still alive.

Before 1975, the Japanese also vaccinated their children, beginning at the age of three to five months. In the years following, they noticed an alarming rise in the morbidity and mortality of these children. As a result, they changed the age at which to begin vaccinations to 24 months and made them no longer mandatory. What followed was an 85% to 90% reduction in severe reactions and deaths among these children.

The DPT and the MMR vaccines are thought to cause autism by interfering with normal myelination of the nerves in the brain, or demyelination of the nerves already coated.

Pertussis is thought to be the most dangerous of the vaccines given to babies. When this vaccine became mandatory in 1978, the incidence of whooping cough went up 300%. There have been numerous outbreaks of this in recent years all across the United States, with the majority of people contracting it in the vaccinated group.

An article in the *Journal of Anthroposophic Medicine* (1992) concluded that the MMR vaccine is ineffective and

dangerous. It was also noted that a high vaccination rate in the US is not able to stop measles outbreaks, and there is now an unusually high complication and death rate with measles that was unseen before the vaccine was instituted.

(Source: Denise Thompson, "Do Vaccinations Cause Learning Disabilities and Behavioral Problems?", *Nature's Field* magazine, Jan/Feb 1997)

UK PRESS REPORTS ON CLINTON CORRUPTION ANGER WHITE HOUSE

Most American travellers will agree: if you want to find out what is going on in the US (or the rest of the world), read the British or European newspapers.

The Washington correspondent for the London *Sunday Telegraph*, Ambrose Evans-Pritchard, has done an admirable job reporting on the developments surrounding President Bill Clinton's ever-growing list of scandals. In fact, he has done such a good job that the White House has been caught running a smear campaign against all journalists reporting on such scandals.

In a 331-page report, released in early January by the Legal Counsel's Office, the White House described a conspiracy "food chain" in which a putative right-wing cabal led by the reclusive heir to the Mellon banking fortune, Richard Mellon Scaife, skilfully feeds material to the London newspapers.



... GLOBAL NEWS ...

Blaming journalists for being involved in a "right-wing" information food-chain, Clinton has virtually accused the British press of fabricating many of the scandals kept away from the US media glare.

Another cause of intense frustration at the White House, according to Evans-Pritchard, is the emergence of a new mass media that does not respond to the usual levers of control.

Stories run by foreign newspapers such as the *Sunday Telegraph* can be picked up by the Internet and transmitted instantly across America, to be amplified by the growing number of citizens radio shows. The White House has not figured out a way to jam the transmissions, so it has resorted to shameless propaganda, referring to such newspapers and shows as "right wing".

Ironically, though, the report has now backfired. The White House, in its zeal to discredit critics, has given a fresh lease of life to the very articles on Vincent Foster that caused so much angst in the first place.

(Source: *The Weekly Telegraph*, 15-21 January 1997)

DIVERSITY & DEPOPULATION

"Two million acres in Kentucky and Tennessee to be depopulated; 500,000 people to lose their homes..."

According America's CNN (Cable News Network), a meeting is scheduled for 1 March 1997, at Murray College in Kentucky, to discuss the movement of half a million people in 17 counties across

Kentucky and Tennessee.

A special congressional committee will hear testimony from ecologists on why this move must be accomplished. Very few from the opposing side will be able to speak on this issue. Homes, businesses, farms and lives will be abandoned should the opposition not be successful.

But how can "they" do this? Very few Americans, even environmentalists, know that this change means the end of living in a free society with a decent standard of living.

These ideas were at the heart of the Biological Diversity Treaty that was officially created during the Earth Summit in Rio de Janeiro in 1992. While this 20-page treaty looked harmless, there are sections that will cause massive changes in your life. In Article 25 there was to be a Global Biodiversity Assessment (GBA). This document of many thousands of pages outlines the plans to change the world.

In the GBA, the following is stated: "Societies dominated by Islam and especially Christianity have gone farthest in setting humans apart from nature... In the process, nature has lost its sacred qualities." (Section 8.3.5)

"Human beings are merely one strand in nature's web and are no more important than any other living creature. Therefore, the natural way is right, and human activities should be molded along nature's rhythms." (Section 9.2.3.1.2)

Also in the GBA: "Population growth

has exceeded the capacity of the Earth, and to maintain our current global population of 5 to 7 billion people we must reduce our standard of living to that of an agricultural world in which most human beings are peasants. A reasonable population estimate for an industrialized society would be 1 billion people." (Section 9.2.3.2)

To summarise other sections of the treaty, a heavy global tax would be levied on agriculture, forestry, mining and golfing. Heavy consumption taxes are to replace income taxes to discourage the use of automobiles, air conditioners and other items deemed non-essential to basic human needs.

(Source: From Kenneth White, via the Internet, 19 February 1997; KWhite9472@aol.com)

DID THE FED KILL JFK?

Theories abound as to who killed President Kennedy and why. Most conspiracy researchers agree, however, that the order to kill the President came from within the US military-intelligence hierarchy.

But one clear-cut and well-defined motive has never been successfully circulated to any great degree.

Not many people realise it, but shortly before his assassination, JFK had issued an Executive Order, which, in some people's estimation, would eventually have abolished the US Federal Reserve entirely.

Known as Executive Order 11110, it reads in part as follows:

"Amendment of Executive Order No. 10289, as amended, relating to the performance of certain functions affecting the Department of the Treasury"

[Introductory stuff snipped.]

"(j) The authority vested in the President by paragraph (b) of section 43 of the Act of May 12, 1933, as amended (31 U.S.C. 821 [b]), to issue silver certificates against any silver bullion, silver, or standard silver dollars in the Treasury not then held for redemption of any outstanding silver certificates, to prescribe the denominations of such silver certificates, and to coin standard silver dollars and subsidiary silver currency for their redemption,"

"(June 3, 1963)"

Given that only the President of the USA can issue an Executive Order, and that only a President can repeal it, I am sure that this EO caused considerable concern to power-brokers behind the US Federal Reserve (the Fed), which, incidentally, is a privately

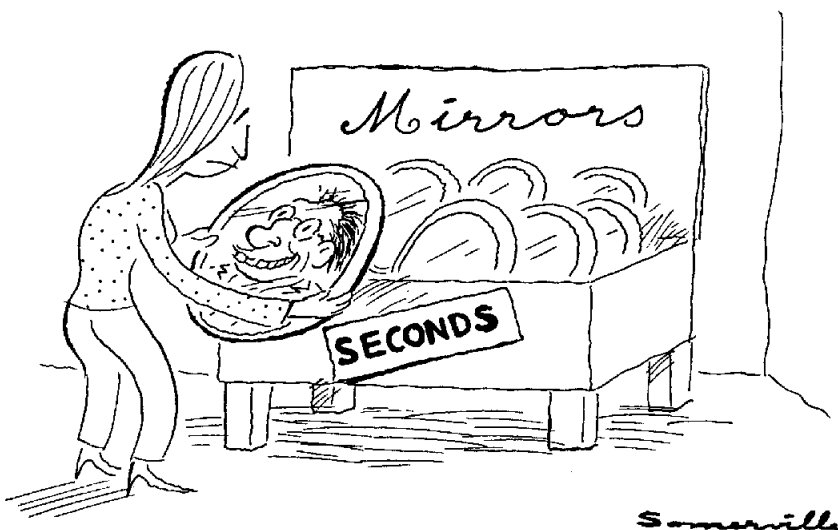

owned organisation, *not* a government body.

Also of interest is that one of the very first acts of business by the new President (LBJ) was to repeal this Executive Order.

(Source: *Free Speech News Wire, fsnw-1@lists.primenet.com via the Internet*)

COMMERCIAL SPY SATELLITES OPENING FOR BUSINESS

Spy satellite photographs were once the exclusive domain of security agencies, but now they are about to become available to anyone with a credit card.

Companies like EarthWatch, scheduled to launch its first commercial spy satellite in April, are now able to offer satellite photos capable of distinguishing objects within a square metre for less than US\$1,000.

To order a photo, customers need only phone or e-mail the company, giving a map reference and a credit card number. The instructions are transmitted to the satellite which takes the photographs within three days then beams them back to Earth.

EarthWatch company officials say the technology will benefit many people including tax officials, who can check on farmers suspected of not declaring earnings from crops; insurance companies looking at homes which are at risk of flooding, with the view to increasing premiums; commodity brokers who gamble on future crop prices and want to see how crops growing in various countries are progressing; fishing fleets who want to see where fish are gathered; people looking for a house in a remote city or country who can 'visit' it without actually going to it; and so on.

However, some governments are positively uneasy about this sort of access. Israel is upset that extremist Arab groups will now be able to obtain military-level intelligence value from these satellites; China is upset that its suppression in Tibet will be exposed; and Turkey fears its assaults on the Kurds may also be revealed.

Commercial and military intelligence agencies are expected to be the largest purchasers of high-resolution images from these probes. The biggest loser is likely to be the US Government, which once used its spy satellites to maintain a huge military advantage over rivals—a superiority used with devastating success in the Gulf War.

(Sources: *The Guardian Weekly [UK]*, 4 August 1996; *The Sunday Telegraph [Aust.]*, 9 March 1997)

CASHLESS SOCIETY JUST AROUND THE CORNER

The cashless society may have taken a long time coming but when historians look back, 1996 will prove to be the watershed year when the convergence of technologies made it all possible.

In the past few months, three important developments have converged: an explosion in electronic banking that has transformed consumer acceptance of new technology; technological developments in 'smart cards' and the acceptance of international standards by the big players; and a surge in acceptance in using the Internet.

All three are complex in their own right. Their convergence virtually assures that the cashless society is inevitable—and it may be here sooner than you think.

According to the Reserve Bank of Australia, the number of automatic teller machines (ATMs) overtook the number of bank branches for the first time in 1996. The number of bank branches fell from 6,655 branches in 1995 to 6,507 in 1996 and the trend towards fewer branches looks certain to continue, thanks to the coming round of mergers and takeovers in the banking sector and the switch to more ATMs by all banks. The number of ATMs increased by 17 per cent over the last year.

Another sign of public acceptance of electronic banking is the number of EFTPOS transactions which in the last year surged by 38 per cent to 470 million transactions.

The next stage of ATM development, expected as soon as the middle of next year, will see an expansion in what clever machines can do with new technology being developed by NCR.

Soon you will be able to buy concert tickets and phone cards, get new cheque books and even electronically speak to tellers—all on an ATM.

While people are now becoming increasingly familiar with electronic banking, the next phase of electronic technology that is about to be unleashed will make an even bigger impact on the way we conduct our finances.

Smart-card technology, which enables microchips to be installed on credit-card-like plastic, has enabled stored-value cards to be produced so that people can swipe cards through special machines and make small purchases without cash. Several trials in Australia and many other overseas trials have confirmed their commercial viability and popularity.

But last week, a giant leap forward was taken when the UK-based Mondex announced a merger with MasterCard that will cut out rivalry, set international standards for smart cards and speed the introduction of smart-card technology.

If, as is widely expected, the Mondex-MasterCard group is joined by Visa, which is the most advanced of the card groups in developing encryption devices that prevent fraud, then electronic commerce through smart cards will be easy and safe to use.

But when the trends towards acceptance of electronic banking and of smart cards that enable new types of transactions are added to the third major trend—an explosion in the use of the Internet—then the combination is truly of historic importance.

Business is clicking onto the Internet boom. While not many companies have made much money out of it yet, that's not stopping a major push into electronic commerce.

Australia's online services alone are now estimated to be a A\$140 million industry.

New research by McNair Anderson shows that older and richer Australians in the 40-plus age group are 'surfing the net'—just what companies developing home shopping and electronic home payments are seeking.

Advertising, a key to making money on the net for many companies, is also beginning to take shape. A new joint venture between Internet server OzEmail and Rupert Murdoch's BSkyB is an ambitious attempt to develop a massive new advertising market that faces some big challenges; but it appears to be just a question of *when*, not *if*.

Many critics and cynics have said that the cashless society would be just like the 'paperless office'—a myth in the minds of technology developers. But this time, the technology developers may well be proved right.

(Source: *Business News*, 28 November-11 December 1996)

ALONG CAME THE *TRANSNATIONALS*

For over a century, corporations have been pursuing their relentless drive for power and profit at the expense of ordinary people.

CORPORATIONS AS 'LEGAL PERSONS'

Many of us sense that the end of history will occur sometime during the next century. We pick up the newspaper and then look out the window, hoping to explain the eeriness of the front page. If there's a full moon in the sky, then maybe, just maybe, the approaching millennium isn't as close it seems. This might at least give us time to quibble over which aspect of social life—cultural, economic, ecological or political—will prove most unstable during the decline of Renaissance man.

Those who escape thought-reform at the end of history may trace our decline back to 1886, when the US Supreme Court declared that corporations are legal persons whose life, liberty and property are protected by the Fourteenth Amendment. Ratified to protect freed slaves, it took railroad-company lawyers less than two decades to turn this amendment into a loophole. By 1904, corporations controlled four-fifths of the nation's industrial production. Today, transnational corporations [TNCs] control the world's cultural and economic production as well, and generate most of its pollution.

A mere three decades ago, investment abroad meant that a US corporation anticipated a foreign market for goods produced domestically. Today it means factories in many countries, through complex global sourcing, production and sales networks. The labour movement, which created the middle class by stunting corporate growth during the first half of this century, can no longer keep up with these changes. Neither can governments. Since the first trade deficit in 1971, the US has shifted from the world's largest creditor nation to the world's largest debtor. By 1991, foreign-owned firms controlled half of the US consumer-electronics industry, a third of the chemical industry, a fifth of the auto industry, and half of the film and recording industry.

The political clout of corporations has kept pace with their economic growth, so there's no longer any need for absurd Supreme Court decisions. Now a lawyer can shop for a congenial offshore bank, deposit a briefcase of mumbo-jumbo in a room with an empty desk, and claim corporate sovereignty anywhere in the free-trade world. Not satisfied with the collapse of Socialism, nor with the worldwide integration made possible by advances in communications, transnationals are setting up international courts such as the World Trade Organization (WTO), packed with their own puppet judges.

Never before have corporations enjoyed such power. Many of the few hundred transnational giants are bigger than most nations. The economy of Ford is larger than Saudi Arabia's and Norway's, and the annual sales of Philip Morris exceed the gross domestic product of New Zealand.¹ Corporate hierarchies are rigidly totalitarian. As the transnationals control more of the world, this inescapably means a loss of rights and resources for many of its citizens.

US law was the first casualty of this corporate onslaught. Originally, corporate charters were designed to serve the public interest. These were State charters. There is no mention of corporate rights in the US Constitution, and very few rights came from legislation. As late as the 1870s, states were still removing charters, which were seen as legal fictions, when they no longer served the public. Charters were granted for fixed terms, and owners, managers and directors were responsible for corporate debts and any harm caused by the corporation, sometimes at double or triple the damage.

Then came the trusts. New Jersey was the first US state to grant corporations any right they wanted. As money flowed into New Jersey, other states did the same thing.² Lawyers hired by the trusts created through the courts a body of case law which continues to grow stronger. In *Buckley v. Valeo* (1976), the Supreme Court decreed that corpora-

by Daniel Brandt ©1996

First published in *NameBase NewsLine*
No. 14, July-September 1996

Public Information Research
PO Box 680635
San Antonio TX 78268, USA
E-mail: info@pir.org

Web: <http://www.blythe.org/NameBase/>

tions are legal persons with First Amendment rights of free speech—and corporate cash is a form of speech. Two years later, in *First National Bank v. Bellotti*, Justice Lewis Powell's opinion was that corporate spending to influence votes during a referendum campaign "is the type of speech indispensable to decision-making in a democracy, and this is no less true because the speech comes from a corporation rather than an individual."

Three justices, Byron White, William Brennan and Thurgood Marshall, dissented in the *Bellotti* case. They argued that corporations are "artificial entities" whose "special status" has "placed them in a position to control vast amounts of economic power... The State need not permit its own creation to consume it."

Two other decisions in 1986 expanded the rights of corporations in elections. In a dissent to one of these decisions, Justice Brennan added that "resources in the treasury of a business corporation...are not an indication of popular support for the corporation's political ideas."³

THE IMPACT ON LOCAL ECONOMIES

Democracies don't stand a chance against these giant treasuries. Corporations can control the way the world thinks simply through the power of saturation. In 1989 they spent over US\$240 billion on advertising and another \$380 billion on packaging, design and other promotions. This amounts to a total of \$120 per person around the world, or double what the average citizen of Mozambique earns in a year.⁴ And it seems that one result of saturation advertising in the Third World is a decline in the perception of class differences. By focusing on the product rather than the lifestyles of the rich, a semblance of equality is projected: everyone has access to the same thrills in a can of Coca-Cola.⁵

Farmers in India had better hope that Coca-Cola will suffice, because transnational corporations want them to stop what they've been doing for generations—namely, swapping seeds for the mutual benefit of the community. Under the intellectual property-rights provisions in GATT (the General Agreement on Tariffs and Trade), which are now enforced by the WTO, farmers are expected to pay royalties to patent-holding companies such as Cargill, the world's largest grain company.⁶ And in Canada, one effect of the free-trade agreements is to give US pharmaceutical corpora-

tions the clout to stop generic drugs, which are available there at a fraction of the cost.⁷

Transnational economic agreements, beginning with the International Monetary Fund (IMF) and World Bank 52 years ago, have escalated in the last decade with NAFTA, GATT, and now the WTO. In response to the 1982 debt crisis in the South, the IMF and World Bank imposed "structural adjustment programs" on poor countries as a condition for new loans. While the loans themselves are guaranteed by the US taxpayer, the "adjustments" benefit only the rich investors. The aim is to weaken domestic entrepreneurial groups in poor countries by eliminating protectionist barriers, price supports and government services. Frequently the currency is devalued, communally-held lands are privatised, and production is reoriented towards export rather than subsistence.

The official justification is that government bureaucracies are holding back development. What's good for business is good for the whole community, for free trade is the rising tide that lifts all boats. But, in practice, this means the deregulation of economic activity, the privatisation of functions once public, and the commercialisation of activities once social. In short, it means a net transfer of power from governments and the people to transnationals and private wealth.

Although governments are too often undemocratic, their mandate is to represent the public interest. Sometimes they stand or fall based on how well they fulfill this mandate. Corporations, on the other hand, are never democratic and frequently claim that their only obligation is to the bottom line of their shareholders. Their transnational character makes them almost immune to organising. If you manage to restrict their activities in one location, they can come back to haunt you.

The most tragic example of this occurred during the early 1970s, when transnationals were just beginning to feel invincible. A coalition of international banks and corporations, led by ITT, secretly worked together to put pressure on a new democratic government in Chile. Eventually Richard Nixon and the CIA joined the effort, which resulted in a bloody coup and years of repression. Presumably it also resulted in happy shareholders.

Poor countries have always wanted foreign exchange for industrial machinery, but now they need foreign exchange just to feed their people. The model imposed by the World Bank requires poor farmers to plant high-margin export crops in order to earn enough to buy imported food. This becomes risky at best, as international commodity prices can fluctuate unpredictably. In Mexico, government support of domestic agriculture has declined by 70 per cent since the mid-1980s. Many Mexicans, whose buying power declined by 60 per cent during that decade, cannot afford imported corn and beans.

The export model encourages migration from the land to the cities, and, to the extent that city slums offer little hope, it also encourages migration across national borders. The logic promoting this is that small farmers are 'inefficient' producers compared to export-driven agribusiness. About a quarter of all fruits and vegetables imported into the US are now from big companies operating in Mexico where labour and land are cheap, exchange rates are attractive and

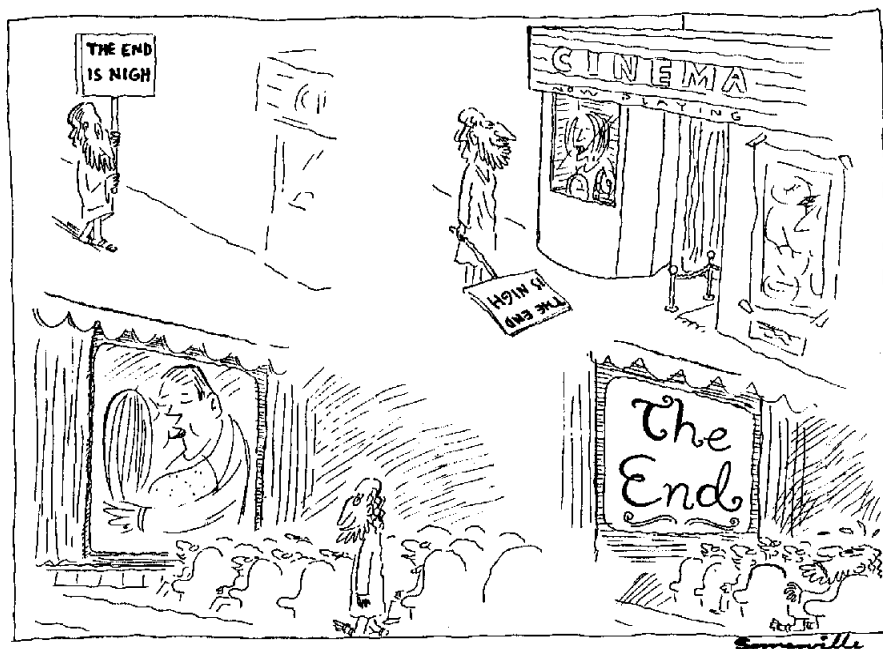

environmental laws almost nonexistent.⁸

To feed themselves, many Mexicans end up working in the 2,000 factories along the border, where US companies pay 89 cents an hour for industrial jobs that were once filled by union labour in US factories. NAFTA was designed to encourage this trend and increase the profits of transnational corporations. During the negotiations between India and the IMF in 1991, one of the IMF's loan "conditionalities", which India resisted, was a cut in food subsidies. "It is clear that hunger, if not starvation, has become an instrument of economic adjustment," writes Jeremy Seabrook, a critic of development trends.⁹

United Nations experts predict that half of the world's population will live in cities by the turn of the millennium, and two-thirds by the year 2025. Already, these experts say, 500 million people living in cities are homeless or live in inadequate housing.¹⁰ Governments are unable to cope with this level of urbanisation, and shanty towns sprout faster than they can be torn down. As governments are forced by the transnationals to become less responsive to the needs of the people, it's unclear what will happen over the next several decades. Meanwhile, the transnationals couldn't care less what happens, as long as their profits increase. Since no one is in a position to tell them differently, they claim that it's not their problem.

The political and economic impact of transnationals in developing countries has been apparent for 25 years, but only recently has this global "rollback", as Noam Chomsky calls it, been felt in the US as well. This term comes from Cold War doctrines that aimed to destroy Soviet power, but Chomsky uses it to describe today's war against the social contract that once mediated between public and private interests. Freedom, democracy, human rights and other threats to authority, which evolved through many decades of social struggle, are being rolled back in favour of the discipline of the unregulated market, resulting in predatory capitalism and the "nanny state" with its welfare for the rich.¹¹

Only the classical economist from a corporate-funded think tank, or the libertarian who places property rights above human rights, bothers disputing the accumulated evidence. Bankruptcies, credit card delinquencies and consumer debt are all at record highs.¹² Falling wages and downsizing are the norm, and Social Security and Medicare may not be there for the next generation of retirees. The figures are in: the US middle class is rapidly disappearing.

CORPORATE TAX PRIVILEGES

Less publicised is the shift in taxation from corporations to individuals. In the 1950s, corporations operating in the US paid an average of 39 per cent of all Federal income taxes, but in the 1980s this figure shrank to 17 per cent. The same is true at the local level. In 1957, corporations generated 45 per cent of property tax revenues, but by 1987 their share dropped to about 16 per cent.¹³

Ronald Reagan's 1981 tax cuts were a bonanza for corporations. General Electric had profits of US\$6.5 billion from 1981-1983 and saw its tax burden go from \$330 million a year to minus \$90

million per year. GE used the rebates not to create jobs (50,000 were slashed from the payroll), but to acquire companies like RCA and NBC. Most new investment by US corporations during this period occurred in foreign countries. "American taxpayers, in other words, were unwittingly subsidizing the globalization of their own industrial structure."¹⁴

Transnationals also use "transfer pricing" to avoid taxes. With operations around the world, it's a simple matter to arrange transactions so that the profits show up in jurisdictions with lower taxes. When California attempted to compute taxes on the basis of assets in the state rather than the corporations' declared profits in the state, Sony chairman Akio Morita went to work and organised campaign contributions to California legislators. Twenty-seven states had followed California's lead, but all of them repealed their laws. California kept the law, but added a provision to exempt any corporation that paid a modest fee.¹⁵

Although another Federal tax law in 1986 was sold as an attempt to restore the balance between corporations and individuals, it didn't work out that way. This new law allowed corporations to deduct their interest on debts, while curtailing the same privilege for consumers. Speculative instruments such as futures markets, stock options, leveraged buy-outs, and mergers and acquisitions continued, financed with corporate borrowing. Now we have a 'casino society', with corporate debt at record levels in response to short-term financial considerations and a decline in tangible assets, such as new plant and equipment, relative to GNP.

Governments are unable to steer this juggernaut. Every day over a trillion dollars pass through worldwide currency exchanges, and an estimated \$150 billion in US Government bonds changes hands. About 10 per cent of these figures involves the normal transfer of goods and services, while the rest is purely speculative. "A financial crisis could assume global proportions in the blink of an eye," said Michel Camdessus, managing director of the IMF, at the June 1996 meeting of G7 leaders in Lyon, France.¹⁶

The tail of US debt is now wagging the dog of US policy. When Bill Clinton came into office with plans for a "stimulus package", bondholders considered this inflationary. The threat that they would unload their bonds meant that interest rates would be driven up. This would have slowed the economy and cancelled out the stimulus package. Clinton's idea was killed at birth.¹⁷

BATTLE FOR THE PUBLIC INTEREST

It's clear that our public institutions are unable or unwilling to ask transnationals to operate in the public interest. Thousands of lawyers, lobbyists, trade association employees, think-tank experts, public relations specialists, politicians and prominent journalists are drawing fat fees, on one level or another, by fronting for free trade and the private interests of international speculators and transnationals.

Aligned against them are a rapidly-increasing number of activists from around the world. They come from labour movements on the left to anti-globalist and anti-immigration movements on the right, and include environmentalists as well as inde-

The economy of Ford is larger than Saudi Arabia's and Norway's, and the annual sales of Philip Morris exceed the gross domestic product of New Zealand.

pendent experts on Third World development issues. All of them are now focusing on the effects of unregulated globalisation, which is emerging as the most important political issue of the 1990s.

Because of the economic and environmental pressures that motivate the activists opposed to globalisation, this will be an important issue well into the next century. Social life promises to get worse before it gets better. World population will increase from 5.5 billion to more than nine billion in the next 50 years, with 95 per cent of this increase in the poorest regions of the world. This growth rate is clearly unsustainable, as it depends on an ecosystem that's losing its capacity to support even current numbers, given the inability of governments to organise in the public interest.

For travelling author Robert D. Kaplan, the anarchy and chaos of West Africa is a premonition of the future, "the symbol of worldwide demographic, environmental and societal stress."¹⁸

Borders become mere conventions used by mapmakers, as refugee migration, smuggling, official corruption, criminals and armed rebels all contribute to the general disintegration:

"It is time to understand 'the environment' for what it is: *the* national-security issue of the early 21st century. The political and strategic impact of surging populations, spreading disease, deforestation and soil erosion, water depletion, air pollution, and, possibly, rising sea levels in critical, overcrowded regions like the Nile Delta and Bangladesh—developments that will prompt mass migrations and, in turn, incite group conflicts—will be the core foreign-policy challenge from which most others will ultimately emanate."¹⁹

Kaplan wrote this three years ago, before the term "globalisation" was used as a handle to identify those private interests that are contributing to the problem. Even when direct acts by the transnationals are not seen as the problem, it is still the case that only these private interests have the wealth and resources necessary to improve the public welfare. Unfortunately, they have yet even to express an interest in lending a hand.

Judging from the people behind Kaplan, he might not use the word "globalisation" today. Kaplan sees the next century with an eye toward its strategic implications for national security, rather than in terms of international class conflict. This isn't surprising. Kaplan received support from the US Institute of Peace and the Foreign Policy Research Institute for expanding his article into a Random House book. Both of these sponsors are linked to the US intelligence community.

While Kaplan captures the sense of social dissolution felt by many of us, his imagination is limited. He envisions a world where private security forces and proxy armies are in perpetual low-intensity conflict with disenfranchised marauders, armed cults and organised gangs. Given this scenario, it's easy to guess which side the Pentagon and CIA will support, for our national security elites were bought and paid for long ago by the transnational elites. There aren't yet any politicians with the clout to challenge this establishment, and only a handful with the courage. But this does not preclude the possibility of organised, effective opposition to globalisation.

THE POWER OF CORPORATE PROPAGANDA

Currently, the major battle is over popular culture and information—a battle for the hearts and minds of consumers and citizens. More precisely, it's a battle that will determine whether the average person will have a heart and mind at all, after another generation of 'McCulture' and infotainment. The question of "Why Johnny can't dissent" is answered by watching MTV and its many imitators. The boundaries between advertising, entertainment and information—with MTV's three-second interviews with political figures—are being utterly destroyed. Special effects have replaced content. These debased messages and images, many coming from a television that's on 50 hours a week in the average American home, has caused a serious decline in literacy and critical thought. Even newspapers, such as *USA Today*, have turned the news into easily-digested bites surrounded by colour.²⁰

Behind the canned news and advertising of the ideology industry are thousands of well-paid professionals. At many universities, journalism schools now share resources with public relations and advertising courses under the same "communications" department. PR practitioners in the US now outnumber reporters, and some of the best journalism schools send more than half of their graduates into these firms.

The distinction between journalism and public relations is fading everywhere. Some estimate that about 40 per cent of all video "news" is fed from PR firms to newsrooms. Journalists get two versions: a slick final version, and a raw one that they can edit. Most budget-conscious newsrooms simply present the slick version as hard news. And worthwhile new books are becoming rare: today's literary agents and publishers consider a promising investigative exposé to be a manuscript that offers titillating gossip about private lives in Hollywood.

It's the rich corporations that can afford the services of PR professionals. Nearly every major advertising agency either owns or is paired with a large PR firm. Along with those catchy "video news releases" that newsrooms love so

much, some PR firms offer industrial espionage, infiltration of civic and political groups, planted stories and phony grass-roots campaigns. Their corporate clients call this "integrated communications". The grass-roots campaigns, commonly referred to as "astroturf movements", are disguised as concerned citizens driven by conscience to petition the government. Since big money is available just underneath this façade, many politicians are no doubt grateful for the cover that "astroturf" provides.²¹

Frequently, PR firms flack for foreign governments and must register with the Department of Justice as foreign agents. Not so long ago, our media was more like a bumbling giant, certainly less centralised and seemingly less homogenous. In a story that made headlines in 1978, Prime Minister John Vorster was forced to resign when South Africa's apartheid government earmarked millions for the secret purchase of two major US dailies, the *Sacramento Union* and the *Washington Star*. After the scandal broke, South Africa had to settle for increasing the number of US public relations firms on its payroll: in 1979 there were 22, and by 1984 there were 31. Haiti, Indonesia, the Philippines, South

"The twentieth century has been characterised by three developments of great political importance: the growth of democracy, the growth of corporate power, and the growth of corporate propaganda as a means of protecting corporate power against democracy."

Alex Carey

Korea and Turkey also used PR firms.²²

South Africa's attempt to purchase newspapers no longer seems so scandalous. Today's smart dictator would merely create an off-shore holding company with laundered money, and purchase newspapers as an 'investment'.

Our culture is so saturated with debased messages that abuse of media power rarely shows up on our radar. Even government officials get involved with illegal propaganda. In the mid-1980s, the US State Department, with CIA assistance, set up its own PR front and called it the Office of Public Diplomacy (OPD). This was a "private, domestic network designed to influence the Congress, the media and public opinion on behalf of the Administration's policies as related to the Iran-Contra affair." The investigation of OPD was minimal, and soon forgotten.²³

The media of the 1990s is significantly different from the media of the 1970s and 1980s. During the Gulf War, Hill & Knowlton, then the world's largest PR firm, collected US\$11 million from their Kuwait account. One of their tricks was to arrange the testimony of "Nayirah" (full name unstated) to the Congressional Human Rights Caucus. This 15-year-old sobbed while telling how she witnessed Iraqi soldiers in a Kuwaiti hospital pulling 312 babies from their incubators and putting them on the cold floor, then leaving with the incubators. This story was repeated countless times before the war started three months later. Even George Bush used it. After the war, it turned out that Nayirah was the daughter of the Kuwaiti ambassador, her testimony was coached by Hill & Knowlton and the entire story was false. Since the US Senate supported the war by a mere five-vote margin, this story may have made a difference.²⁴

The media's behaviour during the Gulf War had a different quality to it. Their disinterest in anti-war demonstrations around the country was matched only by their fascination over Pentagon video clips from the nose-cones of smart bombs. The latter was understandable, since access to stories from the front was controlled by the Pentagon under its new "journalist pool" system. But the former felt strange for many demonstrators.

Spectacular society leads us to dismiss our own experiences when it diverges too far from the official story. For example, the sustaining energy of the anti-Gulf War demonstrations in US cities was in part drained by trivialising, limited media coverage. In San Francisco, 100,000 anti-war protesters were just another "opinion" alongside 300 pro-war protesters in the suburbs. The reality of living through such a large demonstration became hard to believe when it was not reinforced in the *real* public sphere—television.²⁵

Twenty years ago, journalism schools were popular, in response to Robert Redford and Dustin Hoffman in the film *All the President's Men*. For a time there was even a television series about storefront lawyers, battling in court for the rights of the little guy in return for poverty-program wages. Fast forward to the 1990s, and watch a pack of coiffured, vacuous TV 'journalists' scratching for the best angle on one of O.J.'s lawyers every day for many months.

Herbert I. Schiller, a retired communications professor and author of some 10 books, has squarely placed the blame on the big corporations:

"What corporate domination of culture means is that those who get jobs in the varied cultural fields are subject, in different measure, to the commanding logic of corporate business. This logic insists on the unquestioned priority of extracting the largest profit possible from the specific cultural product. It should provide as well, unless it interferes with profitability, ideological comfort and support to the prevailing social order. These are the working

instructions, hardly necessary to be put into manuals, for the employee cohorts of the cultural industries. Employees, whatever their rank and status, disregard them at the cost of their job security."²⁶

Alex Carey, an Australian writer who died in 1988, goes even further. One of Carey's biggest fans is Noam Chomsky, who mentions Carey in interviews and speeches. Carey traces the history of corporate propaganda from the early part of the century, drawing on the American experience but with an emphasis on its lessons for Australia. "The twentieth century," Carey wrote, "has been characterised by three developments of great political importance: the growth of democracy, the growth of corporate power, and the growth of corporate propaganda as a means of protecting corporate power against democracy."²⁷

If Carey were alive to consider the globalisation issues emerging during the 1990s, he might have added a fourth development: along came the transnationals. But he would be correct to remain focused on corporate propaganda, which is where the struggle is being waged today.

SAFEGUARDING OUR 'STAKEHOLDINGS'

Our first task is to devalue the word "shareholder" in our vocabulary. US corporate law holds that the management of publicly-held companies must act primarily in the economic interest of shareholders. Federal law should return to the spirit of early state laws, perhaps by substituting the word "stakeholder" for "shareholder". Stakeholders include everyone—not only shareholders, but also employees, customers and local communities. If there is any justification at all for granting superpower corporations the rights of a person, it can only be in proportion to their respect and concern for *all* of the people.

In addition, Congress and the Supreme Court should require the President to justify any giveaway of our nation's power to govern its own affairs. Our sovereignty is at risk. This has long been of concern to conservative populists, but recently the labour movement and environmental movement have also spoken clearly on this issue.

A window of opportunity for some effective and timely organising has abruptly come into view. If we fail to take advantage of it, this window may disappear just as unexpectedly.

Continued on page 89

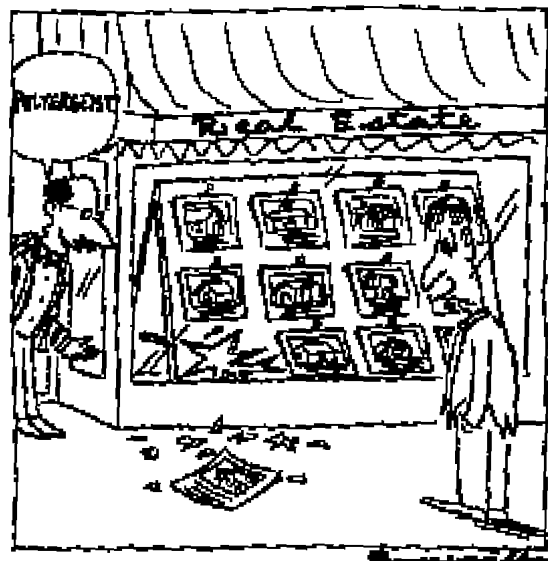

Soybean Products *A Recipe for Disaster?*

Numerous studies show that soybean-based products are not as healthy for us as we'd like to believe.

© by Joseph G. Hattersley

From the forthcoming book
Stopping Crib Death
co-written with Dr Lendon Smith and
due for publication 1997-98.
Extracts originally published in
Townsend Letter for Doctors & Patients
May 1996

INFANT FORMULAS IN 'HOT WATER'

Sudden infant death is not so sudden at all. As I argue in my book (co-written with Lendon Smith, MD), crib (or cot) death is neither random nor sudden, and the causes are known. Preventive techniques have been known and used with 100 per cent success for 40 years, and many studies have been published.

This book has been written with new mothers in mind, and the benefits of breastfeeding are emphasised throughout. However, the fact is that some babies will *not* be breastfed. So, it is appropriate here to suggest alternative, healthy formulas for feeding these babies, and also to raise some of the problems associated with various types of commercial formulas. Indeed, this information is relevant to the good health and well-being of us all, so we would do well to take it on board.

Concerning formula for babies who are not being nursed, important information is provided by Sally W. Fallon, M.A., and Mary G. Enig, Ph.D., in *Health Freedom News*, September 1995 issue. Sally Fallon has extensively studied genuine versions of native cooking methods. Dr Enig, associated with the University of Maryland, is regarded as the greatest American authority in the field of lipid chemistry, i.e., the chemistry of fats and oils. The following passages on soy products are drawn heavily from their important article, and are quoted with their permission.¹

"The soybean contains large quantities of a number of harmful substances. First among them are potent enzyme inhibitors which block the action of trypsin and other enzymes needed for protein digestion. These 'anti-nutrients' are not completely deactivated during ordinary cooking and can produce serious gastric distress, reduced protein digestion and chronic deficiencies in amino acid uptake. In test animals, diets high in trypsin inhibitors cause enlargement and pathological conditions of the pancreas, including cancer.¹

"The food industry touts soy products for their cancer-preventing properties. Isoflavone aglycones are anticarcinogenic substances found in traditionally fermented soybean products. However, in *non-fermented* soy products such as tofu and soy milk, these isoflavones are present in an altered form as beta glycoside conjugates, which have no anticarcinogenic effect.² Some researchers believe the rapid increase in liver and pancreatic cancer in Africa is due to the introduction of soy products there.³

"While fermented soy products contain protein, vitamins, anticarcinogenic substances and important fatty acids, they can under no circumstances be called nutritionally complete. Like all pulses [members of the legume family], the soybean lacks the vital sulfur-containing amino acids cystine and methionine, which our bodies do not synthesise. These are usually supplied by rice and other grains in areas where the soybean is traditionally consumed.

"Soy should never be considered as a substitute for animal products like meat or milk. Claims that fermented soy products like tempeh can be relied on as a source of vitamin B12, necessary for healthy blood and nervous system [and much more], have not been supported by scientific research."⁵

Soy protein isolate is the main ingredient of soy-based infant formulas. That means, "the soy protein isolated from the carbohydrate and fatty acid components that naturally occur in the bean. Soybeans are first ground and subjected to high temperature and solvent extraction processes to remove the oils. The resultant defatted meal is then mixed with an alkaline solution and sugars in a separation process to remove fiber; then it is precipitated and separated using an acid wash.

"Finally, the resultant curds are neutralised in an alkaline solution and spray-dried at

high temperatures to produce high-protein powder. This is a highly refined product in which both vitamin and protein quality are compromised, but some trypsin inhibitors remain, even after such extreme refining! Trypsin inhibitor content of soy protein isolate can vary as much as fivefold. In rats, even low-level trypsin-inhibitor soy protein isolate feeding results in reduced weight-gain compared to controls.⁶

"Soy product producers are not required to state trypsin inhibitor content on labels, nor even to meet minimum standards; and the public, trained to avoid dietary cholesterol, a substance vital for normal growth and metabolism, has never heard of the potent anti-nutrients found in cholesterol-free soy products.⁷

"Along with trypsin inhibitors, these formulas have a high phytate content. Use of soy formula has caused zinc deficiency in infants.⁸ Aluminum content of soy formulas is 10 times greater than milk-based formula, and 100 times greater than unprocessed milk.⁹ Aluminum has a toxic effect on the kidneys of infants, and has been implicated as causing Alzheimer's disease in adults [recent research points the finger of guilt strongly at mercury from amalgam fillings].¹⁰

"Soy milk formulas are often given to babies with milk allergy; but allergies to soy are almost as common as those to milk.¹¹ Use of soy formulas to treat infant diarrhoea has had mixed results, some studies showing improvement with soy formula while others show none at all.¹²

"A number of other substances, which are unnecessary and of questionable safety, are added to soy formulas including carrageenan, guar gum, sodium hydroxide (caustic soda), potassium citrate monohydrate, tricalcium phosphate, dibasic magnesium, phosphate trihydrate, BHA and BHT [butylated hydroxytoluene, an artificial antioxidant; neither it nor BHA has been proved safe for human consumption]. Nitrosamines, which are potent carcinogens, are often found in soy protein foods, and are greatly increased during the high-temperature drying process.⁶

PHYTATE INTERFERENCE

"Not surprisingly, animal feeding studies show a lower weight-gain for rats on soy formula than those on whole milk, high-lactose formula;¹³ similar results have been observed in children on macrobiotic diets which include the use of soy milk and large amounts of whole grains. Children brought up on high phytate diets tend to be thin and scrawny.¹⁸

"Also known as phytic acid—an organic acid—these phytates are present in the bran or hulls of all seeds; they block the uptake of essential minerals—calcium, magnesium, iron and especially zinc—in the intestinal tract. Phytates found in soy products interfere with zinc absorption more completely than with other minerals.¹⁴ Zinc is called the intelligence mineral because it is needed for optimal development and functioning of the brain and nervous system. It plays a role in protein synthesis and collagen formation; it is involved in the blood-sugar control mechanism and thus

protects against diabetes; it is needed for [immunity and for] a healthy reproductive system."¹¹

Literature extolling soy products tends to minimise the role of zinc in human physiology and to gloss over the deleterious effect of diets high in phytic acid.¹

"Only a long period of fermentation will significantly reduce the phytate content of soybeans. Thus-fermented products such as tempeh and miso provide nourishment that is easily assimilated; but the nutritional value of tofu and bean curd, both high in phytates, is questionable. Asian and oriental children who do not get enough meat and fish products to counteract the effect of a high phytate diet, frequently suffer rickets, stunting and other growth problems.¹⁵

"Scientists are in general agreement that grain- and legume-based diets high in phytates contribute to widespread mineral deficiencies in third world countries.¹⁶ Analysis shows that calcium, magnesium, iron and zinc are present in the plant foods eaten in these areas, but the high phytate content of soy- and rice-based diets prevents their absorption.

"The soybean has a higher phytate content than any other grain or legume that has been studied.¹⁷ Furthermore, it seems to be highly resistant to many phytate-reducing techniques such as long, slow cooking. In test animals they cause enlarged organs, particularly the pancreas and thyroid gland, and increased deposition of fatty acids in the liver."^{18,19}

TRYPSIN INHIBITORS AND DENATURED PROTEINS

"Trypsin inhibitors and haemagglutinin, a clot-promoting substance that causes red blood cells to clump together (a situation that hardly promotes cardiac health), are both found in soybeans. They have both been labelled 'growth-depressant substances'. These are deactivated during the process of fermentation.¹ This involves soaking in an alkaline solution. The puréed solution is then heated to about 115°C (239°F) in a pressure cooker.

"This method destroys most (but not all) of the anti-nutrients but has the unhappy side-effect of so denaturing the proteins that they become very difficult to digest and much reduced in effectiveness.²⁰

"The phytate content remains in soy milk to block the uptake of essential minerals. In addition, the alkaline soaking solution produces a carcinogen, lysine-lysine, and reduces the cystine content, which is already low in the soybean.²¹ [Cystine/cysteine are essential for liver detoxification of the hundreds of chemicals to which we are all exposed every day, mostly indoors.] Lacking cystine, the entire protein complex of the soybean becomes useless unless the diet is fortified with cystine-rich meat, eggs, or dairy products.

"The growth of vegetarianism among the more affluent classes has greatly accelerated the acceptability and use of these ersatz products. This helps American farmers to sell their enormous yearly output of soybeans. Unfortunately, as we have seen, they pose numerous dangers."¹¹

The fatty acid profile of the soybean includes large amounts of

The soybean has a higher phytate content than any other grain or legume that has been studied.

... these phytates are present in the bran or hulls of all seeds; they block the uptake of essential minerals—calcium, magnesium, iron and especially zinc—in the intestinal tract.

beneficial omega-3 fatty acids compared to other pulses; but these omega-3 fatty acids are particularly susceptible to rancidity when subjected to high pressures and temperatures. This is exactly what is required to remove oil from the bean, as soybean oil is particularly difficult to extract.

Hexane or other solvents are always used to extract oil from soybeans, and traces remain in the commercial product.¹ Hexane is "any of the five colorless, volatile, liquid hydrocarbons C₆H₁₄ of the paraffin series". Do you really think that ingestion of hexane, even in tiny quantities, will benefit your baby?

COWS' MILK-BASED FORMULAS

What about cows' milk-based formulas? Studies have linked modern commercial milk products with serious afflictions such as allergies, asthma, arthritis, autoimmune diseases, cancer, childhood anaemia and heart disease. For example, Dr J. C. Annand made an epidemiological study of the effect of milk pasteurisation on cardiac and stroke mortality in the 1920s. He found there had been a significant sudden rise in mortality from heart attack and stroke within, at most, two years after the start of compulsory Holder pasteurisation. The milk was heated for 30 minutes to not less than 145°F (62.8°C).²³

A clinical trial appeared to confirm Annand's hypothesis: "All patients suffering from AHD [atherosclerotic heart disease], who maintained a diet devoid of [extended-period] heated milk protein, either showed a sustained improvement in their condition or failed to deteriorate further. On the other hand, patients who for various reasons did not maintain this diet evinced a high incidence of thrombosis and/or cardiac irregularities together with congestive failure."²³

Later, researchers at the Institut National Agronomique in Paris found that consuming plain commercial milk boosted the risk of cataracts among people, especially diabetics, who are able to digest lactose, a milk sugar. Such digestion releases galactose, a substance the researchers blamed for promoting cataracts.

But, natural milk products have a long history of conferring good health in many parts of the globe. For example, the three areas noted for great longevity of local populations—the Caucasus Mountains in the southern republics of the former Soviet Union, the village of Vilcabamba in Ecuador, and the land of the Hunza in northern India—all use whole unprocessed milk products. And Weston Price, studying isolated population groups in the 1930s, found many supremely healthy populations using cows' milk as their principal food.²³ Milk products form the backbone of the Hindu diet.

J. E. Crewe at the Mayo Clinic, in 1929 cured patients of anaemia, hypertension, tuberculosis and many other diseases and conditions using large quantities of raw milk. In his work, pasteurised milk accomplished little against disease because, he wrote, "the heat of pasteurising destroys the enzymes in milk, needed for its complete utilisation and to enable it to do its healing wonders.

"Processing is the problem," according to Fallon and Enig. "The path that transforms healthy milk products into allergens and carcinogens begins with modern feeding methods that substitute high-protein, soy-based feeds for fresh green grass; and breeding

methods to produce cows with abnormally large pituitary glands so that they produce three times more milk than the old-fashioned scrub cow. These cows need antibiotics to keep them well.

"Their milk is then pasteurised so that all valuable enzymes are destroyed: lactase for the assimilation of lactose; galactase for the assimilation of galactose; phosphatase for the assimilation of calcium. Literally dozens of precious enzymes are destroyed in the pasteurisation process; without them milk is very difficult to digest. The human pancreas is not always able to produce these enzymes; overstress of the pancreas can lead to diabetes and other diseases.

"The butterfat of commercial milk is homogenised, subjecting it to rancidity or, even worse, removed altogether. Skim milk is sold as a health food but the truth is that butterfat is in milk for a reason. Without it the body cannot absorb and utilise the vitamins and minerals in the water fraction of the milk.

"Along with valuable trace minerals and short-chain fatty acids, butterfat is America's best source of preformed vitamin D. Synthetic vitamin D, known to be toxic to the liver, is added to replace the natural vitamin D complex in butterfat. Butterfat also contains re-arranged acids which have strong anticarcinogenic properties."²⁶

Further, non-fat dried milk is added to 1% and 2% milk. Unlike the cholesterol in fresh milk, which plays a variety of health-promoting roles, the cholesterol in nonfat dried milk is oxidised and it is this rancid cholesterol that promotes heart disease.²⁷ The multi-source oxysterols injury theory brought together oxysterols from oxidised powdered milk, powdered egg yolk, etc.; those generated internally by homocysteine and from other sources; Matthias Rath's and cellular biologist Bruce H. Lipton's theories into a composite explanation of atherogenesis, the beginning of arterial damages.²⁸⁻³⁰

In Part 5 of my book, I describe how oxidised dried milk can contribute to causing a little-known kind of crib death.

Fallon and Enig point out that "...like all spray-dried products, non-fat dried milk has a high nitrite content [as is well-known, nitrites are carcinogenic]. Non-fat dried milk and sweetened condensed milk are the principal dairy products in third world countries; use of ultra-high-temperature pasteurised milk is widespread in Europe.¹

"Further, soy formulas lack cholesterol, which is absolutely essential for the development of the brain and nervous system; they also lack lactose and galactose, which play an equally important role in the development of the nervous system."¹

What can conscientious mothers substitute, not only to protect their babies from sudden death but to help build their best long-term health? Fallon and Enig have proposed the following¹ for the reasons given above:

"Neither milk-based nor soy-based infant commercial formulas can be recommended for optimal development of the infant. Mothers who cannot breastfeed, for whatever reason, should prepare homemade formula based on whole milk for their babies. The rare child allergic to whole milk formula should be given a whole food meat-based formula, not one made of soy protein isolate. [These suggestions will appeal most to mothers who are not employed away from home.]

... soy formulas lack cholesterol, which is absolutely essential for the development of the brain and nervous system; they also lack lactose and galactose, which play an equally important role in the development of the nervous system.

MILK-BASED FORMULA¹

Makes 32 ounces (approx. 1 litre)

Ingredients:

2 cups (16 ounces, or 0.47 litres) raw organic milk or cultured* milk, not homogenised
1/4 cup whey
4 tablespoons lactose
1 teaspoon cod liver oil
1 teaspoon unrefined sunflower oil
1 teaspoon extra virgin olive oil
2 teaspoons [unrefined] coconut oil
2 teaspoons brewer's yeast
2 teaspoons gelatin
1 3/4 cup (14 ounces/0.4 litres) filtered water
1 100 mg tablet vitamin C, crushed

Method:

Mix gelatin with water and heat gently until gelatin is dissolved. Place all ingredients in a very clean glass or stainless-steel container and mix well.

To serve, pour 6 to 8 ounces into a very clean glass bottle, attach sterilised nipple and set in a pan of simmering water. Heat until warm but not hot to the touch, shake bottle and feed baby. (Never heat formula in a microwave oven!³¹)

Notes:

* Milk cultured with Piima powder for several days will separate into curds and fresh whey. Mothers' milk is richer in whey proteins than cows' milk. Whey assists in the uptake of minerals and contributes to healthy intestinal flora, required for absorption of nutrients and for building a strong immune system. Piima powder, for culturing fresh milk, may be ordered from the Price Pottenger Nutrition Foundation +1 (916) 574 7763.

"Time invested in preparing homemade formula will be well rewarded with the joys of conferring robust good health on your children."

"Public health officials and the National Dairy Council have worked together in this country to make it very difficult to obtain wholesome, fresh, raw dairy products. However, they can be found with a little effort. In some states you can buy raw milk directly from farmers. Whole pasteurised non-homogenised milk from cows raised on organic feed is now available in many gourmet shops and health food stores. It can be cultured to restore enzyme content, at least partially, as noted above. Cultured buttermilk is often more easily digested than regular milk; it is an excellent product to use in baking."¹

Endnotes

1. Fallon, S. W. and Enig, M. G., "Soy products for dairy products? Not so fast", *Health Freedom News*, September 1995, pp. 12-20; published by National Health Federation, PO Box 688, Monrovia CA 91016, USA, phone (818) 357 2181, fax (818) 303 0642.
2. Coward, L., et al., "Genistein, daidzein and their betaglycoside conjugates: Antitumor isoflavones in soybean food from American and Asian diets", *J. Agric Food Chem.* 1993:41, pp. 1961-1967.
3. Katz, S. H., "Food and biocultural evolution: A model for the investigation of modern nutritional problems", *Nutritional Anthropology*, Alan R Liss, Inc, NY, USA, 1987, p. 50.
4. Hattersley, J.G., "High-dose vitamin B 12 for the elderly", for submission to *Townsend Letter for Doctors & Patients* for publication.
5. Scheer, J. F., *Health Freedom News*, March 1991, p. 7.
6. Racks, J. J., et al., "The USDA trypsin inhibitor study; I. Background, objectives and procedural details", *Qual. Plant Foods Hum. Nutr.* 1958:35, pp. 232-240.
7. Fallon and Enig, op cit.

- 8 Lonnerdal, B. et al., "The effect of individual components of soy formula and cows' milk formula on zinc bioavailability", *Am. J. Clin. Nutr.* 1984:40, pp. 1064-1070.
9. Palmer, G., *The Politics of Breastfeeding*, Pandora Press, London, UK, 1993, p. 310.
10. Ely, J. T. A., "Potential break-through on mercury problems", *Well Mind Assoc. Bulletin*, June 1993.
11. Ganse, R., "Doctors still sleuthing cause of food allergies", *Sch. Foodserv. J.* 1986:40, pp. 38-39.
12. Alarcon, P. et al., "Clinical trial of home available, mixed diets versus a lactose-free soy-protein formula for the dietary management of acute childhood diarrhea", *J. Pediatr. Gastroenterol. Nutr.* 1991:12, pp. 224-232.
13. Dukakis, E. S. et al., "Evaluating the nutritional quality of infant formula", *Nutr. Res.* 1989:9, pp. 93-104.
14. Phytate reduction of zinc absorption has been demonstrated in numerous studies; results are summarised in Leviton, R., *Tofu, Tempeh, Miso and Other Soyfoods: The Food of the Future—How to Enjoy its Spectacular Health Benefits*, Keats Pub., New Canaan, CT, USA, 1982, pp 14-15.
15. (a) Mellanby, E., "Experimental rickets: The effect of cereals and their interaction with other factors of diet and environment in producing rickets", *Med. Res. Council* 1925:93, pp. 2-65.
(b) Wills, M. R. et al., "Phytic acid and nutritional rickets in immigrants", *Lancet*, 8 April 1972, pp. 771-773.
16. (a) Van Rensburg, et al., "Nutritional status of African populations predisposed to esophageal cancer", *Nutr. Cancer* 1983:4, pp. 206-216.
(b) Moser, P. B. et al., "Copper iron, zinc and selenium dietary intake and status of Nepalese lactating women and their breast-fed infants", *Am. J. Clin. Nutr.* 1988:47, pp. 729-734.
- (c) Harland, B. F. et al., "Nutritional status and phytate; zinc and phytate X calcium: Zinc dietary molar ratios of lacto-ovo vegetarian Trappist monks: 10 years later", *J. Am. Diet. Assoc.* 1988:88, pp. 1562-1566.
17. El Tiney, A. H., "Proximate composition and mineral and phytate contents of legumes grown in Sudan", *J. Food Composition Analysis* 1989:2, pp. 67-78.
18. Ologhobo, A. D. et al., "Distribution of phosphorus and phytate in some Nigerian varieties of legumes and some effects of processing", *J. Food Science* 1984:49, pp. 199-201.
19. (a) Smith, A. K., *Soybeans: Chemistry and Technology*, Avi Pub., Westport, CT, USA, 1972, p. 183.
(b) Jenkins, M. Y. et al., "Nutritional assessment of twelve protein foods/ingredients", *Nutr. Res.* 1989:9, pp. 83-92.
20. Wallace, G. M., "Studies on the processing and properties of soy milk", *J. Sci. Fd. Agric.* 1971:22, pp. 526-535.
21. Berk, Z., "Technology of production of edible flours and protein products from soybeans", *FAO Agr. Serv. Bulletin* 1992:97, Food & Agriculture

MILK-FREE FORMULA¹

Makes 32 ounces (approx. 1 litre)

Ingredients:

3 1/2 cups (28 ounces or 0.8 litres) homemade broth (beef, lamb, chicken or fish)
2 ounces (56 grams) organic liver, cut into small pieces
5 tablespoons lactose
1/2 cup (4 ounces) whey
1 tablespoon [unrefined] coconut oil
1 teaspoon cod liver oil
1 teaspoon unrefined sunflower oil
2 teaspoons extra virgin olive oil
1 100 mg tablet vitamin C, crushed

Method:

Cook liver gently in broth until the meat is cooked through. Liquefy using a hand-held blender or in a food processor. When the liver broth has cooled, stir in remaining ingredients.
Store in refrigerator and reheat gently as needed.

Continued on page 90

The PEGASUS File

This former CIA deep-cover agent has turned whistleblower at great risk.

His shocking allegations expose powerful names controlling the international drug trade in very high places.

Part 1

by David G. Guyatt ©1997

c/- NEXUS Office
55 Queens Road
East Grinstead, W. Sussex RH19 1BG
United Kingdom

Telephone/Fax: +44 (0)1702 217523
E-mail: david.g7@ukonline.co.uk

Vietnam Special Forces Air Combat Controller; 25-year CIA deep-cover agent; US Army pilot flying classified missions during the US invasion of Grenada; Iran-Contra pilot flying cocaine shipments labelled as medical supplies; and member of the ultra-secret, international G7-run Pegasus "hit team" ...this is the extraordinary story of Gene "Chip" Tatum.

From sensitive, highly secretive (and hitherto largely unknown) Special Forces covert operations in Cambodia, to wandering CIA asset; through to "black ops" activities in Grenada and Oliver North's Iran-Contra "Enterprise", as well as membership in an international "hit team", Gene "Chip" Tatum has seen it all, done it all and is now *telling* it all.

Tatum claims to know where the skeletons are buried. Above all, he is aware that his testimony implicates serving and former US Presidents plus a whole list of high-level government officials and others in a welter of nefarious activities—including assassination, blackmail, coercion, gun-running, money-laundering and cocaine-trafficking.

Tatum, a lanky Floridian, turned whistleblower following his arrest on a treason charge in early 1995. The charge was both astonishing and patently ludicrous, and was later dropped and replaced by a fraud charge—a drastic step-down. Found guilty, he was sentenced to serve a 15-month sentence. In March 1996, an additional charge—conspiring to embezzle—was brought against him. Found guilty, he was incarcerated in Jesup Federal Correctional Facility, Georgia, where he is serving a 27-month concurrent sentence. Ensuuing press interest resulted in one article appearing in the *Tampa Tribune* on 4 May 1996.

Many questions continue to hang over the conduct of the trial. His defence lawyer refused to call any of the 80 witnesses whom Tatum nominated for the defence. Later, his lawyer freely confessed to having come under pressure from the US Department of Defense. Tatum says the first charge was a set-up to discredit him following his "resignation" from "Operation Pegasus". The second charge he views with greater scepticism and concern.

Tatum's resignation from Pegasus followed his refusal to "neutralise" a leading US political figure in the 1992 US presidential elections. Tatum declares he will not "participate in assassinations of any sort, character assassinations or anything, of American citizens". He goes on to explain that back in 1994, in a telephone conference call involving Oliver North, Felix Rodríguez and the late William Colby of the CIA, he was warned to turn over incriminating documents and tapes he had accumulated for his "retirement". He wryly observes that had he done so, he would probably have been quickly "terminated" in an "extreme" way—a speciality of the Pegasus team of which he was once a member.

Countering this demand, Tatum volunteered to plead guilty on a fabricated felony count and serve a 12-month sentence—so that his credibility would be damaged in the event he ever decided to speak out. His incarceration for the second charge—and especially the six-month sentence of his wife, Nancy—led him to speak out about his life, almost 30 years of which he served as a "black" operative, and to reveal and destroy the command structure of Pegasus. It is an extraordinary story.

"OPERATION RED ROCK"

Tatum has written of his early career in the military, and his involvement in a highly sensitive and classified operation, in an unpublished manuscript entitled "Operation Red Rock". Joining the Air Force in February 1970, he went through Army jump school, escape and evasion training, jungle training, sea survival school and diving school and

was assigned along with six others as "Combat Controllers" (the USAF equivalent of Special Forces), receiving his distinctive Special Forces burgundy-coloured beret. From there he was assigned to Tinker Air Force Base, Oklahoma, and then on to Fort Bragg, North Carolina—home of the "Green Berets"—for training in C4 plastic explosives, mines, nuclear, biological and chemical warfare, plus indoctrination in electronic and psychological operations.

Posted to South-East Asia as Airman First Class (A1C) in December 1970, he was assigned as a radio operator on a Forward Air Control (FAC) aircraft attached to Task Force Alpha at Nakhon Phanom, Thailand. In short order he was recruited (an involuntary "volunteer") to "Team Red Rock". The team was composed of eight US Army Green Berets, three US Navy SEALs and two "cowboys"—a euphemism for CIA paramilitary specialists. With Tatum attached, Team Red Rock totalled 14 in all, and was about to be tasked with an operation that came directly from the White House.

In January 1971 the team received a final briefing from General Alexander Haig, who had flown in specially, along with CIA Saigon Chief William Colby—nicknamed by the team as "Mr Peepers" because of his resemblance to a well-known character in a TV sitcom. Haig and Colby outlined the plan, stressing its importance and extreme classification. President Nixon, desperate to quell domestic riots over an increasingly unpopular war, sought to withdraw all US personnel from South-East Asia. Withdrawal would—and, in the end, ultimately did—cause a military vacuum, quickly leading to the defeat of South Vietnamese forces.

During those years, Nixon was also running a "secret war" in Cambodia and Laos. In Laos, a dwindling number of Meo tribesmen, together with covert US personnel employed by the CIA proprietary company, Air America, were battling against superior

North Vietnamese ground forces. A much similar pattern was occurring in Cambodia, amid grave fears that the "domino theory" would result if either of these two nations were to fall to the Communist North Vietnamese. Nixon hoped that the vacuum caused by the withdrawal of US covert forces could be filled by native Cambodian forces. Lon Nol, the Cambodian leader, stubbornly continued to resist Nixon's diplomatic overtures to take up the slack, being anxious to hedge his bets and realistic about his chances of survival as Khmer Rouge and Vietnamese forces prepared to swarm in, unhindered by US air power.

A plan had been drawn up at the highest levels of Nixon's administration. Team Red Rock were to enter Cambodia's capital, Phnom Penh, in secret and attack the airport and military and civil installations, wreaking as much havoc as possible. The plan called for the team to parachute into the outskirts of Phnom Penh, carrying captured NVA "Sappers" with them. Taken in unarmed and alive, the Sappers would be "sacrificed" and their bodies left to be discovered by Cambodian forces. A furious Lon Nol would assume North Vietnam was to blame. It was hoped that such an act would stiffen Lon Nol's backbone. With nowhere else to turn, the US puppet would urgently seek US hardware to strengthen his forces and continue the battle.

The team members were not told that they, too, were to be sacrificed by their President to ensure that word of the operation never reached the light of day. A detachment of Montagnard tribesmen ("the Yards"), in the pay of the CIA, was assigned to liquidate each member of the team and dispose of the bodies. The attack went successfully, but the team's suspicion of "the Yards" foiled the betrayal. Using their knowledge of "escape and evasion" tactics, the team decided to trek to the Vietnamese border and back to safety with US forces.¹

Casualties thinned out their numbers until only eight of them remained. Soon these, too, were captured by NVA regulars and underwent hideous torture at the hands of Chinese and Russian interrogators. Ultimately, only Tatum and one other team member survived the ordeal.

Convalescing, Tatum was debriefed by CIA station chief, William Colby, and told he would, in future, be kept close to "the Agency". Recruited into the CIA, the yawning door of future "black" operations creaked open. Life would never be the same again for Chip Tatum.

CIA DEEP-COVER AGENT

For the next 10 years or so, Tatum's covert activities were varied. For a while, he worked out of Homestead Air Force Base where he was NCIOC of the tower receiver sight and MARS station. This was the base which then-President Nixon used for his frequent visits to the Key Biscayne, Florida, "White House". Much of this period remains obscured behind a thick blanket of classification.

From there, he was stationed in northern Italy, tasked with visiting the border towns of Yugoslavia and Italy. Colby felt that as a young Air Force man, Tatum might be "approached" in these towns for "information". The idea was to make contact with foreign agents and covertly gather information about them and their operations. Later, he was tasked with infiltrating Yugoslavia in order to gather intelligence on potential successors to the then

The team members were not told that they, too, were to be sacrificed by their President to ensure that word of the operation never reached the light of day.



Yugoslavian President Tito.

Tatum was also sent to search for missing US POWs from Vietnam and elsewhere in South-East Asia.

By 1976, Tatum was operating out of Lamar, Colorado, in a communications facility called OLAB. His contact there was Don Holmes, president of Valley—a Savings & Loan bank.² Tatum acted as his courier, shuttling between Lamar and Springfield, Colorado, with transaction files. From there he was transferred to MacDill Air Force Base, Tampa, Florida.

Shortly before his MacDill posting, Tatum received a call from Colby telling him he was resigning his position as Director, Central Intelligence, and recommending Tatum should deactivate his clandestine CIA activities. Colby continued, saying that remaining active without Colby there to protect him might place him in personal "jeopardy", as he had powerful enemies in Washington. This warning referred to Nixon, Kissinger and Haig, and Tatum's role in and survival from "Operation Red Rock".

Tatum took good notice of the warning and became deactive. Later, in 1979, he requested and was granted entry into a USAF Reserve program. Leaving active military service he moved to Gunnison, Colorado, and took up a position with Bo Calloway, owner of the Crested Bute ski area. The appointment was arranged by Colby.

During 1980 he received a visit from two men who informed him he was being reactivated, but into the US Army instead of the Air Force. He was sent to the US Army Flight School for rotary-wing training at Fort Rucker. From there he was assigned to the 160th Aviation Battalion/Special Forces at Fort Campbell, Kentucky. Shortly afterwards, the 160th combined with others to form Task Force 160.

It was in this unit that Tatum played a "spooky" role in the US invasion of Grenada. A photograph of him standing in front of his MD-500 Defender gunship on the beach-head in Grenada, appeared along with a feature story in the Louisville *Courier-Journal*. Tatum will only say of this episode that he "wasn't there", in the same sense that he "wasn't in Cambodia".

At that time he was attached to the US Army's 160th air wing at Fort Campbell. Not only was the Hughes helicopter then *not* in the Army's inventory, but the 160th didn't officially exist. Jim Malone, of the Louisville *Courier-Journal*, finds this extraordinary. He has documents showing the 160th was stationed at Fort Campbell, even though officials in the Pentagon continue to deny it—as they deny the wing's role in Grenada. Malone, in a telephone conversation with this writer, advised that the 160th is now stationed at Fort Bragg, North Carolina—home of the famous Special Forces, the Green Berets. Their mission is to fly "Delta teams" on covert assignments, Malone added.

THE CONTRA COCAINE TRAIN

During 1983, Colby established contact again, advising Tatum he would shortly be contacted by "a man called North". This, as Tatum was to discover later, was none other than Lt Col. Oliver North—the central architect of America's Nicaraguan Contra campaign. Besides fighting a covert war, North was also the link-

man in much, much dirtier work.

The "Contragate" years teem with well-documented accounts of illicit wholesale gun-running and dope-smuggling. The exposé series published in Autumn 1996 by the San Jose *Mercury-Post*, entitled "The Dark Alliance", openly finger-points at the CIA and the Reagan administration for turning a blind eye to massive cocaine smuggling. Moreover, the series of articles claims that the explosion of "crack cocaine" in Los Angeles resulted entirely from the Contra leaders—*cum*—dope peddlers who made vast personal fortunes from their activities. Today, the official argument remains that the Contras were "freelancing" without the knowledge or consent of their CIA "handlers" or North's so-called "Enterprise". Despite these assertions, mountains of hard evidence point in a different direction. Included in this evidence is an entry from North's own diary which shows his knowledge of cocaine shipments.

In stark contrast to these denials, Tatum says that North's "Enterprise" not only set up the cocaine factories and "ran" the Colombian cartels, but was also responsible for masterminding the massive shipments of narcotics into the US. Significantly, he is not alone in making these accusations. A number of those involved in Col. North's operations have subsequently come forward and spilled the beans. Almost all of these "whistleblowers" have been hounded and imprisoned. Some have died, whilst others have fled.

The whole Contra thing, Tatum states, was also being used by an extremely covert group called Pegasus.

During February 1985, Tatum was piloting "Dustoff" (Medevac) flights for the US Army's 3/498th Medical Company, stationed at Fort Stewart, Georgia. Two flight crews, including Tatum's, were transferred to Palmerola Air Base, Honduras. Each flight consisted of a pilot, copilot, medic and crew chief. Once familiarised, they assumed the Medevac mission for Joint Task Force Bravo.

Previously, in 1984, Tatum infiltrated the 3/498th on the instructions of Lt Col. Oliver North who had established contact under the code-name "Jake" (North had "control" of the 160th air wing and was also deeply involved with the tactical planning of "black ops" missions in the Grenada invasion).

On 15 February 1985, during a flight to La Ceiba, Honduras, he was instructed to contact his local "handler", Major Felix Rodríguez—later to prove a major figure in the Iran-Contra investigation. Rodríguez informed Tatum that in addition to his Army "Medevac" duties he was to support covert "Pegasus" missions. These, he was told, would take priority over his other duties. He was also given his "chain of command": three individuals, any of whom could authorise Pegasus missions.

In addition to Oliver North and Felix Rodríguez, Tatum would henceforward take orders from Amiram Nir, a former Mossad agent and advisor to Vice President Bush. Aviation support for Pegasus missions operated out of Ilopango Air Base, Honduras (home of the CIA proprietary airline Corporate Air Services) plus numerous Contra camps located in the jungles and mountains

Tatum says that [Oliver] North's "Enterprise" not only set up the cocaine factories and "ran" the Colombian cartels, but was also responsible for masterminding the massive shipments of narcotics into the US.

along the Honduras-Nicaragua border.³ A common feature of all future Pegasus missions was the transport "of large white coolers in and out of the Contra camps".

On 26 February 1985, Tatum and his crew were instructed to fly two individuals to one of the larger Contra camps on the Honduran border. His flight log lists the names of the two individuals as Bill Cooper and Buzz Sawyer, both of whom worked for Corporate Air Services. Following a meeting between the CIA agents and Contra leaders, Tatum was given a sealed cooler, marked "Vaccine", weighing approximately 200 pounds, and instructed to deliver it to a USAF C-130 transport plane at La Mesa Airport, Honduras. Two crew members offloading the cooler accidentally dropped it, breaking the seal. Inside were over 100 bags of cocaine. Tatum resealed the cooler and later watched as it was transferred aboard the C-130, outward bound for Panama.

On his return to Palmerola Air Base, Honduras, Tatum phoned Col. North to advise him of his discovery. North replied that it was "a trophy of war" and that the "Sandinistas are manufacturing cocaine and selling it to fund the military". North closed the conversation by saying that "the cocaine was bound for the world courts as evidence" against the Sandinistas.

The whole incident struck Tatum as odd and reminded him strongly of earlier missions dating back to 1983-84 when he was stationed at Fort Campbell, Kentucky, as a Special Operations pilot. Regularly he would trans-ship white coolers, marked as "Medical Supplies", to Little Rock Air Force Base, Arkansas. On two occasions he carried similar coolers to Mena Airport, Arkansas. Deliveries of medical coolers to Little Rock AFB were picked up by Dr Dan Lasater—a close confidant of the then Arkansas Governor Bill Clinton.

By now, almost two years later, Tatum had decided to document his discovery to safeguard his "retirement". Thereafter, he documented all Pegasus flights on the reverse of his flight logs.

This was a difficult time for Tatum, since he had three balls to juggle at the same time. On the one hand he was flying classified active-duty missions for the US Army; on the other, he was flying CIA missions arranged through Mil. Group A (CIA), located at the embassy in Tegucigalpa, Honduras; and thirdly, he was flying Pegasus missions under the control of William Colby, Oliver North and George Bush following his recruitment into Pegasus by Colby in 1986.

Tatum completed numerous missions during his rotation out of Honduras. Picking up and trans-shipping coolers containing cocaine was a regular event. Extraordinarily, this included infiltrating Nicaraguan airspace (Tatum says it was not difficult to

infiltrate any country and that "foreign powers" would kill to know how it is done), and landing at Bluefields Air Base with deliveries for placement aboard civilian C-123s and C-130s.⁴ This mission was followed by a brief stint in Colombia, where he was assigned to assist the Drug Enforcement Administration's "War on Drugs", only to discover the DEA was heavily engaged in narcotics trafficking.

THE "BOSS HOG" LIST

One of the most flamboyant individuals involved in the cocaine trail from Columbia through Honduras to Panama and on into the United States, was Barry Seal. Seal flew an assortment of aircraft, offloading shipments of weapons in South America and picking up deliveries of cocaine for his return flight to the US on behalf of Col. North's Enterprise. His primary base of operations was Mena Airport, Arkansas.

A CIA "asset", Seal was later arrested and became a DEA informer. Prior to his killing in 1986—allegedly by a Medellín cartel assassination squad in revenge for informing on them—Seal openly boasted he had information that implicated high-level government officials, including then-Vice President Bush, in the Enterprise's narcotics-trafficking business.

Tatum would soon get to meet Barry Seal and become close friends. Tatum recalls being present during a meeting between Oliver North, Felix Rodríguez, Amiram Nir and General Alvarez from Honduras, when North stated

that Vice President Bush was going to have his son Jeb arrange "something out of Columbia". This conversation focused on Barry Seal's increasingly notorious activities. When Tatum later heard Seal had died, he immediately understood who was behind the killing. The discussion also made it clear that VP Bush, Governor Clinton and his three respective "handlers" were knee-deep in the

cocaine venture and making fistloads of money.

Unknown to all those present, Seal had earlier provided Tatum with a list of names of those high-level government officials deeply involved with or responsible for controlling the narcotics business. Seal called them the "Boss Hogs". Tatum has kept this list a tightly-held secret until recent weeks. The list cites the surnames only, and is reproduced above, as I received it, complete with misspellings as written. I have appended their full names and titles in brackets.

Most, if not all of these names are readily familiar to Contragate investigators and journalists covering this story. Allegations regarding the involvement of former President

"BOSS HOGS" — UNITED STATES

- Casey (William Casey, Director Central Intelligence)
- Clair-George (Clair Elroy George, Head of CIA's Central American Task Force)
- Bush (Vice President George Bush)
- Kissinger (Dr Henry Kissinger, Chairman, Kissinger Associates; former US Secretary of State; former National Security Adviser)
- Haig (General Alexander Haig, former Secretary of State)
- Greg (Donald Gregg, former National Security Adviser to VP Bush, Ambassador to Korea and alleged joint "Controller" of Panama's Manuel Noriega, along with William Casey)
- Clairage (Duane "Dewey" Clarradge, CIA)
- Fernandez (Joseph Fernandez, CIA Costa Rica Station Chief)
- North (Lt Col. Oliver North, National Security Council aide)
- Singlaub (John Singlaub, CIA covert operator)
- Colby (William Colby, Director Central Intelligence, 1973-76)
- Secord (Richard V. Secord, regarded as a "brilliant" CIA black operative)
- Weld (William Weld, head of Criminal Division, US Department of Justice; instrumental in "blocking" Senate investigations into narcotics, according to testimony of former Senate special investigator, Jack Blum)
- Rodriguez (Felix Rodríguez, CIA officer with close connection to VP Bush)
- Peroot (General Peroot, Defense Intelligence Agency)

George Bush in the cocaine business are by no means new—they abound in plentiful supply. The fact that Bush pardoned a number of his closest advisors, who were facing criminal prosecution and possible imprisonment, late on Christmas Eve 1992, just weeks before Bill Clinton's inauguration, left a sour taste in the mouths of many. If prosecuted, they clearly would have fingered the President himself.

PEGASUS: DIRTY MONEY LAUNDERING

But Tatum's story takes us even further along the dark road of power, greed and corruption. During 1986, he had left Honduras and set up a money-laundering business in Watertown, New York State, close to the home base of the Army's 10th Mountain Division at Fort Drum. The location was chosen with care. With access to Fort Drum's telephone lines for secure communications, he was assigned a Cherokee-140 fixed-wing aircraft,⁵ used to ship personnel and supplies across the Canadian border under radar cover. His tenure with these companies lasted from 1986 through to 1990. This was a pure Pegasus operation.

It was at Watertown that Tatum was provided with a civilian cover in the form of three construction companies: American National Home Builders, American Constructors and American Homes. Funding was provided by Henry Hyde, an Illinois Republican politician and well known as the CIA's "black money" man. Hyde provided a US\$250,000 line of credit with Key Bank, Watertown. Although Tatum was listed as the president in all three companies, in reality all were under the control of Ben Whittaker, a lawyer from Rochester, New York. Whittaker, Tatum says, is closely associated with Tony Wilson of the Wilson family who owned Xerox Corporation. They are extremely wealthy and "friends of the Rothschilds and Rockefellers". In addition, he was also closely associated with South Eastern US Investment Group (SEUS)—an investment bank in Savannah, Georgia—from 1985 through to 1989. Another proprietary he was involved with was Irving Place Development, a service organisation of Irving Bank and Trust Company. Cocaine proceeds were laundered through these companies by an ingenious use of construction loans.

In response to a question asking why the "drug-related money" was placed in "Arkansas, Colorado and Ohio", Tatum simply explains that he doesn't know why, adding that "It was being done before I got there. I assume banking laws and whether or not Bush had people in his pocket in these areas." He does explain that the primary figure involved in the laundry exercise in Arkansas was "Jack Stephens". Jackson Stephens, owner of Worthen Bank & Trust Company, is closely aligned with President Bill Clinton. Tatum states that "...Clinton received the cash and divided it up between Stephens and [Dan] Lasater to clean it up. Stephens' company [Worthen Bank] was used as the guarantor, providing 'warehouse' lines of credit."

Developing this theme in more detail, Tatum explains that the Enterprise was receiving drugs in exchange for the guns they supplied to the Contras. The raw product in the form of coca leaves was supplied by the Colombians and pressed into large cube-shaped bales and then shipped to Nicaragua and Honduras.⁶ All the "product" was pre-sold and the delivery into the US "guaranteed".

This eventually resulted in the sale proceeds being pre-paid to Panama, under Noriega's control. Some of this money was washed through banks and other companies operating in Panama and elsewhere. The rest was sent to Arkansas, Ohio and Colorado. Thereafter, the dirty money was filtered via construction loans with permanent "takeouts" "arranged by banks and

mortgage-lenders". These, in turn, were later sold to Fannie Mae's and Freddie Mac's—negotiable US Federal Mortgage Securities that are traded globally on a daily basis. Each laundry "cycle" lasted from six months to a year. The result was dirty money transformed into good, clean, US currency.

This system wasn't arbitrary or accidental. One initial "test-bed" was a small residential mortgage lender named Carl I. Brown (CIB) in Kansas. Others were larger, and still others became national. All were ultimately destined to be purchased by a bank (proprietary) from Japan within a specific time-frame, 1996, as part of ongoing Pegasus plans. Eric Brown, the son of the founder of CIB, was heavily involved in these activities. Three additional companies were involved, to Tatum's knowledge: US Homes, Pulte Homes and Richmond Homes. All became very successful, providing "the American dream—as VP Bush put it in a meeting in 1987".

PEGASUS: ASSASSINATION & NEUTRALISATION

Tatum has gone into considerable additional detail regarding the role of Pegasus as he knew it. He believes Pegasus was established during the Eisenhower years as a secret group inside the CIA to spy on that agency on behalf of the President. At some point—believed to be after the assassination of President Kennedy—Pegasus went AWOL from direct US Government control and came under the direction of an international Board of Directors which Tatum alleges now includes George Bush and Henry Kissinger.

The directors of Pegasus meet once a year in secret conclave

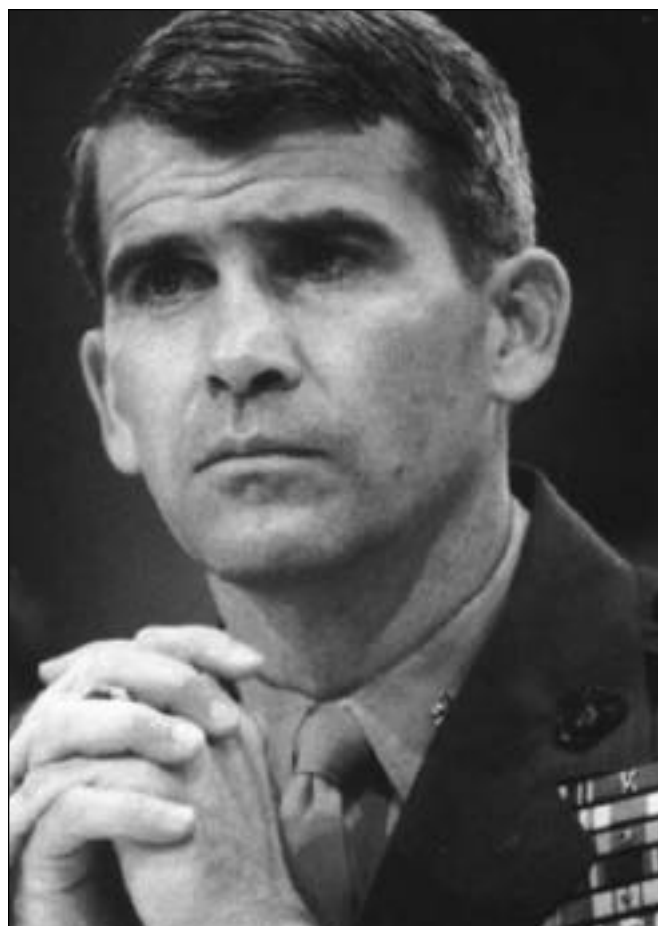

Lt Col. Oliver North, Jr, at the Iran-Contra Inquiry

following G7 meetings. The group has "representation" from a number of intelligence agencies throughout the world. Included are the US Drug Enforcement Administration (DEA), the Central Intelligence Agency (CIA), the Bureau of Alcohol, Tobacco and Firearms (ATF) as well as agents from British, Israeli, Turkish and Danish Intelligence plus "others who performed various functions for Pegasus".⁷ The mission of Pegasus, Tatum explains, is "to 'align' world leaders and financiers to our [US] policies and standards".

One of Tatum's Pegasus duties included flying "Archer Teams" (four-man hit teams) in his helicopter to their insertion point.⁸ He states that Enrique Bermudez was assassinated in 1991 by a Pegasus team, adding he "was shot in the back of the head while walking down the street...from about 150 yards". Bermudez, known as "Commander Three Eight Zero" was the senior Contra leader. Tatum received two broken ribs when he came under small-arms fire during the assassination.⁹

Following the Nicaraguan war, Bermudez sought a prominent position in the new government. Spurned by President Chamorro, "Commander 380" tried to pressure George Bush to intercede on his behalf, threatening to expose Bush's role in the cocaine trafficking enterprise. According to Tatum, Bush ordered his disposal.

Another Pegasus assassination was that of General Gustavo (Dr Gus) Alvarez Martinez, the "cooperating" Armed Forces Commander-in-Chief, Honduras. Alvarez was assassinated in 1989, following his demand for a bigger split of the cocaine profits.

Tatum also describes his involvement in the assassination of Amiram Nir, the former Israeli Mossad agent who went under the assumed name of Pat Weber. Nir was scheduled to testify to the Senate subcommittee and it was feared he would reveal the truth. He perished, following the shooting-down of his aircraft with mis-

siles from Tatum's helicopter.

Other "neutralisations" verge on the bizarre. An individual who must remain nameless for a variety of reasons—but whose name is known to this writer—underwent an experience that is both horrific and chilling. Readers are warned that what follows is not at all pleasant. For the sake of ease, I shall call this individual "Mr X" or, simply, "X".¹⁰

Mr X was a leader of one of the largest CIA-backed Contra groups. He recently testified before the US Senate Intelligence Committee. Formerly, X was a senior executive in a South American subsidiary of a leading US soft drinks corporation. During his Senate testimony, he denied any knowledge of CIA involvement in the narcotics trade, adding that condoning such activity would have been foreign to his way of life. Not so, says Tatum. Mr X had been recruited into the CIA by then-Director William Casey, with the assistance of Oliver North.

In 1990, when Nicaraguan leader Daniel Ortega announced there would be "free elections", X was ecstatic. He began jostling for position and asked President Bush to ensure he be given a prominent position in the new government—in return for his years of toil at the behest of the CIA and the Enterprise. The pressure came in a form that Bush could not ignore.

Failure to help his friend would result in X's intimate knowledge of Bush's involvement in the dope trade being made public. His threat left Bush with a sour taste. A Pegasus team was assigned to "neutralise" him in early 1990.

Mr X, Tatum states, "fancied himself a lover of women. Tall, large-breasted blondes were his favourite. It was determined that, if effectively neutralised, [X] could be an asset. Therefore, it was decided that intimidation would be used to control [X]."

They chose to use the drug Scopolamine, which also went by the nickname "Burundanga" or "the Voodoo drug". The drug is extracted from the pods of a flowering shrub that grows in remote regions of South America. In its processed, powdered form, Scopolamine is "void of smell, void of taste". When properly administered "it causes absolute obedience" without this being "observable by others". Importantly, the target will not recall any of the events that occurred during the period they were under the spell of the drug.

In outlining these details, Tatum adds that it is important to administer the drug in the correct dosage, for he has known targets to die from too high a dose. Others have "remained under the influence of Burundanga for up to three weeks". Precise dosage can be achieved by liquid ingestion, the powder being readily soluble. Ingestion via cigarettes is also an optimum method of ingestion. It is fast-acting and takes no more than 20 minutes to work.

Tatum states that X was invited to spend a relaxing weekend at a luxury hotel as a guest of his friend George Bush. His host for the weekend was a trusted 18-year veteran field-intelligence officer. The evening started with cocktails and was followed by a fine meal. "Nothing but the best" were the orders."

Following the meal, he was ushered into the suite of a "blonde bombshell" supplied by the CIA. Mr X had already ingested a dose of Burundanga during pre-dinner cocktails. X was gallant with the blonde as they both moved into the bedroom where video cameras were already set up in one corner. In short order, the blonde had X standing naked in front of her and began to indulge

The discussion also made it clear that VP Bush, Governor Clinton and his three respective "handlers" were knee-deep in the cocaine venture and making fistloads of money.



US President Bill Clinton and Vice President Al Gore

his desires. All the while, the video cameras whirred. Slowly stripping off, the "blonde" revealed his manhood in all its glory. Mr X was instructed to reciprocate the favour and perform fellatio. He obliged, his intimate activities recorded at 24 frames a second on videotape.

Tatum says the male prostitute was hired from a bar in New York and killed that same evening.

Two weeks later, X—wholly unaware of the events of that evening—was visited in Nicaragua. He was presented with a copy of the video footage, along with instructions. Tatum says that X can never allow that video to be seen: "Not only does it reveal his homosexuality, but it also reveals his bestiality and satanic worship rituals." As frame after frame flicked by, X reportedly wept, forced to watch himself kill his homosexual "lover" and then engage in the most grisly cannibalistic ritual imaginable.

Neutralised, Mr X became a leading member of the Nicaraguan government a few short weeks later.¹¹

PLANNING FOR RETIREMENT

Since 1985, when he first became aware of the Enterprise drug-smuggling, Tatum began collecting documents, audiotapes and videotapes for his "retirement". He was acutely aware that most deep-cover agents do not survive long in what is a very dirty game at a high-stakes poker table.

Tatum says that, in 1992, President Bush instructed him to "neutralise" presidential runner Ross Perot, but he refused to do so. Tatum turned over a copy of an incriminating tape to President Bush, explaining that it would *not* be released—provid-

ing that he, his family and Perot were kept safe. He also told the President that copies of the tape had been placed in six different locations worldwide, saying, "if I didn't contact these capsule-holders by a certain time each year, they are to be sent to the addresses on the packaging". He closed the conversation by stating that when he originally "placed the packages, I gave explicit instructions that if I asked for them to be sent back to me, they were to send them to the addresses on the packages." This, Tatum reasoned, would avoid intimidation or torture.

Note:

Part 2 of David Guyatt's article will cover George Bush's "scope and mission" paper for the New World Order; Chip Tatum's run-down on the counterfeit "Super Bills" CIA scam in Iran; the truth behind the killing of cocaine king Pablo Escobar; the reasons for the US invasion of Panama; the truth behind ex-DCI William Colby's death; more revelations about Clinton's cocaine confidants; and more "Boss Hogs"...

To be continued in the next issue of NEXUS...

About the Author:

Born in England, David Guyatt is a freelance investigative journalist whose former career in stockbroking and banking gave him the background that inspired his research into the shady world of international weapons financing, drug-running and money laundering. His current research interests are focused on military/intelligence mind-control programs and non-lethal weapons systems, as well as the hidden influence of elitist groups around the globe.

Endnotes are continued on the next page

Endnotes

1. Tatum has provided me with a variety of documents covering his military and CIA career from 1971 through 1986 when he was discharged from the US Army. His discharge papers outline a series of military decorations and campaign medals including "The Republic of Vietnam Campaign Medal with Device" and the "Vietnam Service Medal" (there are many others). Appended to these papers is a medical report, signed by Major Charlie Talbert, which outlines Tatum's various injuries gained during his military career—and includes notations describing his capture and torture in South-East Asia. Major Talbert reports that these injuries were treated in June 1972, and adds that Tatum's medical records are incomplete "as details on this are classified". I queried Tatum on the date, which should have been recorded as 1971. He responded, saying it was definitely 1971 and that the Army doctor only had "Secret" security clearance whereas Tatum had "Top Secret" clearance (confirmed in other military records, dated 1972, in my possession). Tatum avers that this discrepancy was the result of a typographical mistake on the part of the Army doctor.

Moreover, Tatum's covert role in the CIA is additionally confirmed by other military papers provided to me. In one dated 1974, Tatum's assignment orders were "cut" by a Lt General USAF (name redacted) who was Chief Military Intelligence Adviser to the Joint Chiefs of Staff.

Other corroborative documents in my possession include a US Army payslip dated 1985; a copy of an "Inmate Request Form" on the Hillsborough County Sheriff's Office, showing Tatum was being detained on a "treason" charge; assignment papers to the 3/498th Medac at Fort Campbell, dated 12 April 1984; copies of media news articles describing the attack on Phnom Penh; a news report and photograph of Tatum in Grenada; a Special Forces USA MED-DAC Mission Request Form dated 6 April 1985, detailing Barry Seal's "Boss Hogs" listing; plus hard copies of Tatum's flight logs dur-

ing his Honduras "rotation", additionally supported by photographs of the original flight logs.

I also have a copy of a TWIX message from the Commander US Forces, Honduras (Task Force Bravo), stating to his superiors that "It has become increasingly evident during the past six weeks that Medevac A/C, in direct support of JTFs, in some cases are being utilised for other than Medevac requirements and are being controlled by other than Medevac Officials." Tatum says he obtained a copy of this message from his Pegasus controller.

I also have a copy of Tatum's full book manuscript, "Operation Red Rock", together with a letter he sent to William Colby, dated 6 March 1996, which threaten: "I will not only write about the missions but about the NWO timetable and planned events, including a chronology. And I will name names."

I have other documents that I am not permitted to reveal but which corroborate missions in South America.

2. The word "contact" is not meant to imply that Don Holmes was a CIA type.

3. Tatum says that, through 1985, "aviation support" for Pegasus was primarily out of Palmerola Air Base, Honduras. Ilopango Air Base is in El Salvador and it had "operational" support.

4. Tatum adds that he had limited flights to Bluefields Air Base, Nicaragua, but "primarily the military aircraft used were USAF C-141s and C-130s at Palmerola, La Mesa and San Lorenzo, Honduras. At San Lorenzo there were also civilian aircraft, including civilian C-123s."

5. In addition to flying rotary-wing aircraft, Tatum was also competent flying smaller fixed-wing craft. He had access to both at Fort Drum.

6. Tatum adds in this connection that they were "supplied with leaves and paste called 'bazooko'...the reason for that was because they were not supplying the paste fast enough, so they needed the leaves to make up for the time. The leaves were brought from Peru."

7. I wrote this sentence based on information

provided to me and also extracted from a long list of Q&As prepared by author Rodney Stich for Tatum's attention (and now in my possession). In reviewing this article for errors and omissions, Tatum stated that "there were no US DEA or ATF agents in Pegasus". This appeared to conflict with an earlier reply to one of Stich's questions which stated, in part, that "DEA was represented. We had DEA agents, ATF agents." Naturally, I wanted this clarified and asked Tatum to explain this quite significant amendment. He replied, advising that "there were joint missions where DEA and ATF agents were used...they were not officially part of Pegasus". Nancy Tatum advises that since Chip Tatum was in prison at the time he answered questions submitted by Stich, the "misunderstanding" was hers.

8. Tatum adds that he also "flew fixed-wing, multi-engine props and jets...for the various missions" and he was not limited to rotary-wing aircraft.

9. These injuries occurred during the departure of the "Team", six hours after the assassination itself, when they came under anti-aircraft fire as they flew low-level across the border. Tatum was wearing two Kevlar (lightweight body armour) vests which absorbed the impact of incoming rounds.

10. Tatum has provided me with the name of this individual, a well-known politician. He also asked that I consider excising this account from the article, for a variety of understandable reasons. I have elected to keep it, as I believe it is both an important and highly significant account.

11. I phoned and spoke with Ron Lard, an official at the DEA HQ, Virginia, to ask about the properties of Burundanga. He was unable to provide any information. However, through other sources I can confirm that this drug is well known to cause both amnesia and a zombie-like trance in which the target follows all orders. Dr Camilo Uribe, head of Bogotá's toxicology clinic, says "it's like chemical hypnotism". See *Wall Street Journal*, 3 July 1995.

The Living Water of Johann Grander

Water can only be truly clean when harmful frequencies have been eliminated from it and vital energies restored.

Austrian naturalist Johann Grander has invented a device that utilises magnetism and spiral motion to reintegrate water's life-force.

© by Jill Fraser

Words on the Wind Communications
Heathmont, Victoria, Australia
Telephone: +61 3 9729 7588
Fax: +61 3 9729 5951

CONTEMPLATING THE LAWS OF NATURE

The story of Austrian naturalist, Johann Grander, revolves around the discovery of an extraordinary truth, the far-reaching repercussions of which affect one of the Earth's most precious commodities: our water. It is also the tale of a remarkable man's comprehension of Nature's laws and his quest to open humanity's eyes to the subtle world that exists beyond science, whilst remaining adamant in his decision to retain a life of simplicity and humility despite an increasingly high profile.

From a very early age it was apparent that the young Johann had inherited his father's fascination with magnetism; in particular, its relevance on a cosmic level. His intrigue with Nature's patterns and cycles didn't seem directly related at the time. In hindsight, however, the link of destiny between the two areas becomes abundantly clear.

Born in April 1930 in Tyrol, Austria, he left school and had already completed several jobs by the tender age of 14. Never giving a thought to furthering his education or formalising his instinctive knowledge of all things natural, he just worked hard in order to survive, and gratefully accepted whatever positions were offered to him.

In 1962, whilst leasing a service station, he started to investigate ways to deal with environmentally harmful petrol fumes, and for the first time he became aware of how his understanding of Nature could be harnessed in a practical sense for the good of mankind.

In 1974 his service station lease expired, so he left his home town and withdrew to the surrounding countryside where he earned a living by building wooden alpine huts on high-lying pastures. It was during this period, whilst working on the alpine slopes, that his intense love of Nature consolidated and strengthened and his observations into the "perfection of creation" became more acute.

Craving a suitable place in which to contemplate and restore his inner quietude he purchased a nearby defunct copper mine, believing that it would provide an ideal atmosphere for meditation but not realising that the spring waters, found deep within the mine, would form the basis for a phenomenal discovery and his ultimate invention.

RESTORING THE LIFE-FORCE TO WATER

Water, the most important element for the continuation of all life on Earth should, by rights, always have been treated with the utmost respect, preserved in its natural, unadulterated, pristine state and kept free from human, animal or chemical contamination.

That, of course, has not been the case. Today, we are aware of the degree of physical pollution that has occurred down the ages in the name of progress. But what we have only just begun to acknowledge (largely due to the insight of two dedicated naturalists, Viktor Schauburger and Johann Grander) is that water is much more than its chemical formula H₂O and its real contribution to the well-being of all living matter occurs on a vibrational level.

Grander didn't set out to investigate the vibrations in water. The profound event, which led to his realisation that the life-force within water can be revitalised by infusing it with its own natural frequency, occurred as the result of a totally unrelated incident that came about after doctors declared that his inflamed, arthritic joint was incurable.

"It was up to me to help myself," he said. "My father had told me about the healing powers of magnetism and I built a massage roller which worked like a bicycle dynamo and generated electrical energy when rolled over the body. In this way I cured my arthritis and became familiar with the healing effects of magnetic forces."

This revelation led him to concentrate on the use of magnetism in healing, to build larger, more efficient devices, and finally to invent a way whereby the artificial source of power could be superseded by natural means.

"I was overjoyed to have made such a revolutionary discovery for mankind," Grander declared.

It was a joy which was to be short-lived however, because the authorities refused to patent his invention. Their decision was revealed to be purely political, based solely on a desire to 'protect' industry and commerce.

With the support, understanding and backing of his family, Grander persevered. When asked what motivated him, he replied, "I feel an invisible hand guiding me."

Grander became more and more adept at utilising the inexhaustible natural forces, but eventually he got to the stage where he needed a greater quantity of batteries than he could afford.

A WORLD WITHIN WATER'S SUBTLE VIBRATIONS

He set about inventing what he described as a "water battery" and one day found that when he switched on the circuit, which was now run by water, the high-frequency energy from the magnetic generator was transferring permanently to the water.

In other words, Grander's simple but sensitive process was re-activating our damaged water with a vibration that had been lost



Johann Grander, naturalist and water revitaliser

Water has the property of being able to transfer information which has entered its memory, to other systems such as living organisms.

for aeons, and at the same time it was restoring its innate vitality.

All of Nature is a 'living being' in mutual vibration with itself. Its dance involves a constant attraction, rejection and transformation and the subsequent release of power, both positive and negative. Water, our most important storage medium, absorbs all the influences in its environment and then passes them onto other living organisms.

Today, the damaged, polluted, artificial landscape through which water flows is producing mostly negative frequencies which, in turn, adversely affect the physical, emotional and spiritual well-being of all life on Earth.

Johann Grander's discovery has opened the door to the reversal of this negative trend by restoring water's natural vibrations and life-force. All that is required is for the authorities to have the insight to see beyond the known, and the courage to take the first step.

The human body is said to be composed of 75 per cent water, and the brain tissue made up of 85 per cent water. To maintain bodily

functions a human needs three litres of fluids a day, for a lack of water will result in certain death over a period of three days because the body can't retain its own reserves.

Humanity has been aware of the preciousness of water for thousands of years. In Rome its contamination was punishable by death, but modern society, driven by progress and a relentless desire for prosperity, has abused its waterways and destroyed water's very essence.

Today, a huge proportion of the world's water supply is undrinkable; not only is it 'sick' or 'dead' water, it is devoid of life-force. This has serious implications for the health of entire populations.

Forced to conform to our highly questionable standards, water is raped by chemicals, effluent, fertilisers, pesticides, acids, fumes, hydrocarbons and fluorocarbons; shoved through tortuous routes using pumps and filters; and then subjected to 'purifying and cleansing' processes until it becomes a commercially viable product which is 'fit for human consumption'.

Water, in its natural state, sustains and renews itself with energy (frequencies) from the stones, rocks, minerals and, indeed, the planets in our solar system. In Nature, every source has a different energy and a different taste because its contents vary according to the minerals and frequencies contained within.

Grander says: "In Nature, water seeks its energy resources by itself and for this it needs its liberty. Natural water flows over and under the earth; it forms its own loops and bends and the entire vegetation benefits from this. Now we deprive water of this liberty by forcing it into canals, by regulating riverbeds, by pressing it through pressure pipes, by adding harmful substances and exposing it to environmental pollution."

WATER POSSESSES MEMORY

By far the most profound and progressive aspect of Grander's discovery was his realisation that water possesses memory. Any life-impeding information that water gathers in the form of harmful vibrations (or information) is not erased by any of our conventional cleansing or purifying processes.

Grander asserts that water is still harmful even after being subjected to filtration and purification processes. He says: "Water, once impaired by metals, nitrates, toxins, etc., remains harmful

even after a thorough processing by chemicals or filtration because negative vibrations that once were stored are still preserved. This is the reason why the use of water is so precarious today. Drinking water may be filtered, irradiated and chemically processed but the harmful vibrations are still being passed on to the organisms of living beings."

Once water has been contaminated with pollutants and damaged, by constantly being forced into unnatural shapes and contours, it is energetically dead and even the best regenerating plants cannot restore it to life.

Modern research confirms that even after chemical or mechanical removal, harmful toxic materials remain present in water in the form of electromagnetic frequencies. These negative oscillations are transferred to the human body and can cause a range of sometimes inexplicable allergies or sickness.

The physicist, Dr Wolfgang Ludwig, explains in the book, *Environmental Medicine*, that: "Water has the property of being able to transfer information which has entered its memory, to other systems such as living organisms. What most people do not yet know is the following fact: while water may have been chemically cleaned and all bacteria eliminated, it still possesses certain electromagnetic frequencies or vibrations of certain wavelengths which, when we take a closer look, can clearly be allocated to exactly the pollutants which were supposedly removed. So even after regeneration, water still contains certain signals which, depending on their wavelength, may be injurious to health."

Dr Ludwig goes on to reveal that certain electromagnetic frequencies of water, polluted with heavy metals, have been found in cancerous tissue. He says that in one German metropolitan area the drinking water, prior to its distillation, had a frequency of 1.8 hertz (very low life-energy) and that experimentation showed that although it had been treated and distilled twice, the low frequency 1.8 hertz still remained—proving that although the drinking water was chemically pure, it remained physically contaminated with pollutant information and therefore retained a low life-force.

Once it is recognised that all living matter is constantly exchanging (giving and taking) vibrations (information), it follows that living matter always seeks the vibration it lacks. Thus our damaged water, which is very low in both energy and vibration, is depleting instead of nourishing us (which may go towards explaining the feeling of tiredness after having a bath.)

A SIMPLE SOLUTION: A PROFOUND INVENTION

Several years after his initial discovery, and after much contemplation in a little wooden hut (which combined as a laboratory and a new 'meditation centre'), Johann Grander invented the now widely acclaimed Living Water energising unit, which captured brilliantly his 'accidental' concept for revitalising water in such a way as to make energised water accessible to everyone.

The potent cleansing and health-giving properties of water have been recognised for a long time, and eminent researchers such as Viktor Schauberger, Theodore Schwenk, Fritz Koch, Henri Coanda, Nikola Tesla, Samuel Hahnemann (the father of homeopathy) and Anton Mesmer had all pre-empted Grander's work.

But Grander discovered what centuries of study by notable scientists, physicists and chemists had failed to find: the key to duplicating Nature's ability to restore a range of vibrational frequencies to water and energise it like a mountain spring. And now he had developed a practical and useful unit for doing just that.

"The high energy which flows from my device cannot be compared with the energy from a power socket," he said. "It is a natural energy in every sense of the word, made up of light vibra-



Implosion experiment with water, carried out by Walter Schauberger

tions. These are natural, vital forces, the strongest of which you can touch without getting an electric shock."

Grander's vision took him where no one else had gone. In fact, his discovery has been described as being as "significant as electricity and the silicon chip" because to possess the knowledge to restore water's life-giving frequencies is to hold the key to transmute all the damage that has ever been done to it by human and chemical pollution and, ultimately, to return to the world its most vital 'element'.

Many countries offered him millions of dollars to buy the secret to his alternative source of energy, but, because he feared that his inventions could end up either getting shelved or placed in the wrong hands, he renounced all offers despite his serious financial difficulties at the time. He says: "I regarded my discovery as a divine inspiration which ought to be further developed."

GRANDER'S LIVING WATER FOLLOWS NATURAL LAW

Hans Kronberger, in his book, *On the Track of Water's Secret*, says: "It is not a theory of miracles that Johann Grander teaches. For him, his research has a simple self-evidence. Grander feels like a 'servant' who is in a position to recognise certain natural processes. His results are far from being miracle cures or some kind of supernatural knowledge... The only miracle is Nature itself."

Grander perceives life to have a spiritual, not a magical, thread which holds it together, and he humbly accepts everything that occurs on his journey as a gift from God.

He says: "As I see it, not a single event in our lives is based on coincidence. This is why I believe that being aware of the fact that everything God allows to happen is important and could help many people to cope with their daily problems, even if they don't immediately see the sense... I was virtually guided towards the water. So, of course, it was not a coincidence... I am grateful that I was allowed to acquire this knowledge for the benefit of the entire creation."

"Above all, I consider it to be a grace that I was allowed to come to this state of humility, which I want to preserve by all means. Because only by this humility, the divine guidance and the divine protection will be maintained... I have recognised how important it is to let oneself be guided instead of always trying to succeed with one's obstinacy."

Explaining the Living Water unit, Grander says that magnetism is information, vibration or power that flows from one pole to the other, and that there is always a giving and a taking pole, corresponding to the principles of plus and minus, yin and yang, etc.

He explains: "With magnetism we draw a distinction...that is, earth or permanent magnetism, which is stationary and in which only certain energies flow and only certain materials (iron) are attracted and ejected; and gravitational magnetism, which is bound to time and space and in which several energies flow and all materials are attracted. And finally, as the highest form, the spiritual or planetary magnetism, which is neither bound to space nor to time, and by which all hereditary information and all vital powers are transmitted. No life would be possible without it. It regulates the mechanism of the three cycles (cycles of the year, month and day) between plus and minus."

Grander's Living Water unit is poled in such a manner that all three forms of magnetism are integrated. He says: "All three natural magnetisms are amplified so that energy starts to flow. This cosmic energy, which is highly efficient and, above all, harmless, changes the structure of the water so that it gains specific magnetic characteristics and high-grade hereditary information... It is the implosive energy that works. Contrary to the explosive energy, which is harmful and destroys Nature, this implosive energy is a gentle, absorbing power which flows from the outside to the inside."

LOW ZETA-POTENTIAL MEANS A CLOGGED SYSTEM

It has been said that Johann Grander's water is the closest mankind has got to producing cellular water—which has trace elements in a special colloidal form that are insoluble in water, do not ionise, and remain suspended due to a natural law known as "zeta potential".

This is the phenomenon by which the billions of circulating cells maintain their discreteness, thus playing a vital role in all forms of animal and plant life. If zeta potential is low, toxins cannot be suspended for elimination and nutrients cannot be suspended

for transportation to the cells—so the whole system becomes clogged.

For hundreds of years others have tried to reproduce cellular water but, before Living Water, no one was able to recreate its unique health-giving properties.

As Hans Kronberger points out that, until relatively recently, Grander's work and discoveries caused him to be labelled a "crackpot" and he was left alone to think and observe in his own beloved natural environment.

Now, since Grander's discovery and invention of 'revitalised' water, doctors, scientists and naturalists come from all over the world to consult with him. Numerous attempts have been made to discredit him and halt his developments, but none has succeeded.

He reflects on the first 10 years of his work, when nobody came to see him, and says that this was one of the most beautiful times of his life. There have been practically no media reports on him because, with the exception of Hans Kronberger, he refuses to have contact with journalists.

In a conversation which took place around a table with friends, and at which Hans Kronberger was present, he spoke of his sadness concerning the fact that most people today have lost their knowledge "of what really happens in Nature and what is really important in life".

He said: "It often hurts when I have to look on and see such a false picture being drawn for people that causes them to become ignorant and blind in respect of Nature. And that is why I wish people themselves would start to think about the processes of Nature again and, through this, learn to respect Nature again... Because this knowledge about Nature can, for the most part, only come from within themselves."

When asked why he doesn't reveal the secret of his Living Water, he replied: "It is not a secret but a natural law. The fact that to many people it seems to be a secret indicates how far science has already digressed from Nature."

It has been said that Johann Grander's water is the closest mankind has got to producing cellular water—which has trace elements in a special colloidal form that are insoluble in water, do not ionise, and remain suspended due to a natural law known as "zeta potential".

References and Further Reading

- Batmanghelidj, F. (M.D.), *Your Body's Many Cries For Water*, Global Health Solutions, Inc., Virginia, USA, 1992, 1995 rev. ed.
- Coats, Callum, *Living Energies: Viktor Schaubergers brilliant work with natural energy explained*, Gateway Books, Bath, UK, 1996.
- Kronberger, Hans and Siegbert Lattacher, *On the Track of Water's Secret: From Viktor Schaubergers to Johann Grander*, Uranus Verlags gmbh, Vienna, Austria, 1995; Books of Revelation, Melbourne, Australia, 1996.
- Ludwig, Wolfgang, in *Umweltmedizin* (Environmental Medicine) (Treven and Talkenhammer, eds.), Mowe-Verlag, Idstein, 1991.

About the Author:

Jill Fraser is a Melbourne-based freelance journalist who writes for a number of publications on a range of subjects including health, spirituality and the environment. She is currently under author contract to Random House Publishing.

Sound Techniques for Tuning your Health

*Modern voice-
and machine-
aided sound
therapies can
restore the range
of harmonious
frequencies
necessary for
complete physical
and emotional
good health.*

by Sharry Edwards ©1997

Signature Sound Works, Inc.
1007 East State Street
Athens, Ohio 45701, USA
Telephone: +1 (614) 592 5115
Fax: +1 (614) 592 6116
E-mail: 104411.3257@compuserve.com

BIOLOGICAL PRINCIPLES AND PROCESSES

Sound therapy can most aptly be described as a cross between music therapy and biofeedback. It is related to music inasmuch as specific combinations of sounds are used; but not necessarily sounds that would be considered musical by even the most lenient critic. Biofeedback comes into play as low-frequency sounds are presented to elicit specific biological and emotional responses.

Some similarities to light therapy are obvious since both use the concept of full-spectrum oscillation. Light as a healing modality seeks to use full-spectrum light, while sound therapy employs the idea of full-spectrum sound.

The process of sound therapy requires two distinct processes if maximum results are to be achieved. First, it is essential to determine the individualised patterns for each person, prior to any actual sounds being provided. Just as important are the sound formula sets that must be specifically constructed and presented to each individual. Both steps must be comprehensively performed to ensure that each person be given the most accurate and complete approach available.

Sound therapy seeks to influence the systems within the body that produce, interpret and use frequency. It was probably performed intuitively as a response to human interactions even before the ability to make and interpret sound consciously was realised. Using computer analysis, the sounds of spontaneous moaning, groaning, yawning, screaming, sighing, laughing, and 'filler' sounds such as "mmm" and "ah" have been found to contain the stressed frequencies that are required to elicit improvement.

The principles of sound therapy originate with the idea that the brain perceives and generates impulse patterns that can be measured as brain-wave frequencies which, in turn, are delivered to the body by way of nerve pathways. The theory incorporates the assumption that these frequency impulses serve as directives that sustain structural integrity and emotional equilibrium. When these patterns are disrupted, the body seeks to reveal the imbalance by manifesting symptoms that are interpreted as disease and stress.

Enquiries by modern as well as ancient researchers have attempted to develop a screening procedure that would accurately delineate the frequency measurements of the body.

BIOACOUSTICS AND THE TOMATIS METHOD

One approach to sound therapy is BioAcoustics, which uses voice spectral analysis as a tool to identify and interpret the constant, complicated frequency interactions within the body. The technique has given insight into the possibility that the frequencies contained in the vocal patterns provide a holographic representation of the human body. (In the animal kingdom, vocalisation patterns are being studied as a representation of the environment. This is a separate branch of BioAcoustics.)

A second approach, known as the Tomatis Method, identifies stressed frequencies by auditory screening. It is based on the principle that the voice contains only what the ear can hear.

Each method is clearly distinct in approach and strategy but both evaluate the body for stressed frequencies. By introducing individualised sets of sound formulas, each approach seeks to establish continuity within the frequency systems of the body.

Although different in approach, evaluation, instrumentation and fields of research interest, both BioAcoustics, using vocal assessment, and the Tomatis auditory method are compatible considering that both have the same goals in mind: structural and emotional integrity.

Auditory assessment for the purposes of sound therapy was founded by Alfred A.

Tomatis, a French physician, psychologist and educator. BioAcoustics, with emphasis on human voice spectral analysis, was originated in 1982 by Sharry Edwards, M.Ed. The foundational work accomplished by these two pioneers will likely support many variations of sound therapy as the data and acceptance expand.

PRINCIPAL CONCEPTS

Sound therapy proposes the idea that the body requires the presence of a full range of harmonious frequencies working cooperatively. Consider the body as a musical instrument. When even one note is out of tune, the result is often discordant. Tune the instrument and the sounds become consonant.

It has long been known that sounds reflected from a metal girdler can predict the integrity of the structure. This parallel was used to develop the process of using sound to test the integrity of bone density and formation. Each structure and process within the body has a distinctive combination of frequencies that must be present for the body to maintain integrity. The body is capable of being self-diagnostic, but not so capable of self-generating the frequencies that are required for restoration.

The idea of using sound to facilitate change within the body is



Sharry Edwards, M.Ed., founder of BioAcoustics

not a contemporary notion. Song and movement to create mood and provide physical dominion over the body was an intimate part of almost every culture on Earth, but those efforts were often surrounded with superstition and mysticism.

It wasn't until recent times that computerised technology and instrumentation was developed that allowed the advancement of procedures that could be used to help the body to predict and prescribe for itself. By correctly interpreting the data, appropriate patterns could be provided to help the body reverse its own disease.

SIGNATURE SOUND FREQUENCIES

According to the word of God and the mandates of science, everything is frequency—and frequency is everything. Science shares this thought by stating that the most common denominator of all structure, the atom, is energy—a form of frequency. An expression attributed to God states that "In the beginning was the Word", and, since sound is also frequency, God joins science in the observation that, at its foundation, frequency is the basis of our universe.

This thought gives credence to the idea that our bodies are frequency and energy. This collection of energy patterns, called a Signature Sound, is a frequency representation of all that we are. If we were to learn the governing patterns of individual Signature Sounds we would be able to interpret and have dominion over all aspects of our mechanical and emotional substance.

Essentially, all forms of curative intervention influence the frequency systems of the body. Heat is a form of frequency; colour is a form of frequency; sound, smell, vibration, homoeopathic remedies, herbs and even medications, at their structural base, are all forms of frequency.

Experiments have been repeated that show that introducing a person the frequency formula for niacin, a nutritive substance, can cause a niacin-like skin flushing—the same as if the person actually ingested the nutrient.

THE EAR AND THE VOICE

No matter what the nature of the input, information is received by the brain in like form. We see frequencies of light that are transformed into electrochemical impulses and sent to the brain. We hear octaves of sound frequencies that are translated into electrochemical impulses and then provided to the brain for interpretation. No matter what we perceive, on what octave, it is all received by the brain via the same route of frequency impulses: brainwaves.

If we are composed of frequency patterns, it seems reasonable to use the most readily available frequency source of the body—the voice—to obtain information about the body. The voice is a source of sound; the ear is the most obvious receiving unit of sound. The voice and the ear form a dynamic system that are extraordinary as inherent diagnostic systems of the body.

Tomatis believes that during gestation the brain is developed from the pattern of the first organ to form: the ear. His techniques have been successful in showing that when hearing is corrected, many learning and emotional problems are eliminated. While the ear deals with innate issues that create the foundation of the energy patterns, the voice is capable of displaying a kinetic account of the body in motion.

VOCAL SOUND ASSESSMENT

As the frequencies of the body become chaotic and manifest symptoms, pain or emotional stress, the vocal print begins to display the same disorganisation.

Using a computer representation of the voice, decibel and frequency levels can be used to identify the stress. The vertical axis is used to show decibel, the horizontal axis to show frequency. Points that are located high on the graph, i.e., "risers", would proportionally represent sound frequencies that are loud and overabundant. Points that are low, i.e., "stringer", would indicate sound frequencies that are not apparent. The objective is to cause the voice to "collect" in a smaller, more unified pattern. Fewer risers and/or stringers would indicate more coherence in a vocal presentation.

AUDITORY SCREENING

The Tomatis Method addresses specific problems of listening, not hearing. Using a listening test, it seeks to evaluate listening strengths and weaknesses. By introducing the ear to filtered and unfiltered sound stimulations through special headphones, the ear is forced to expand its range of perception. Using a patented instrument called the "Electronic Ear", the sounds are gated between two channels and given a precession delay between bone and air conduction. This "filtered music" increases the selective power of the ear.

The client is given the ability to perceive sound with less distortion and to analyse more precisely the fundamental frequencies and harmonics. The Tomatis Method works simultaneously on three levels: functional, emotional and relational.

SOUND FORMULA CREATION AND DELIVERY

Sound therapy should not be confused with frequency therapy that uses ranges that are not considered to be auditory and also delivers the frequencies by way of transducers placed directly in contact with the body. Sound therapy uses ambient sound and/or headphones. The Tomatis Method additionally employs the use of sound delivery through bone conduction.

Sound therapy is very different from music or light therapy because the sounds used are not always within the range of vocal or instrumental octaves. In the case of BioAcoustics, the objective is to entrain brain-waves. To do this, very low frequency sounds are required.

The sounds used by sound therapy are created by frequency-generating and filtering equipment. To involve the client more, both methods encourage the use of the voice as a supplement to mechanical presentations.

The actual results are accomplished by the harmonics of the sound formula formats. Unlike light, sound frequency can be presented over a range of eleven octaves (20 to 20,000 cycles per second), while the known spectrum of visual light is one octave. Shades of light can be extremely varied; shades of frequency can be very precise and

are required to be. In some cases, a difference of .02 hertz can mean the difference between effect and no effect.

AUDITORY SOUND THERAPY APPLICATIONS

Specialities for auditory sound therapy include learning disabilities, problems with speech, language acquisition and development, brain dominance, handedness, singing, hearing and behavioural problems. Vocal sound therapy has had success with varying issues during their research efforts but several specific areas of expertise have emerged—sports injuries and structural problems, pain management, nutritional evaluation and tissue regeneration being among the most successful. Of particular interest in using vocal assessment is the recent finding that implies that the poor use of digestive enzymes is responsible for allergic reactions.

The inventory of unsuccessful outcomes of sound therapy is short. It does not do well against invading forces such as bacteria, viruses, fungi, yeast or parasites, although a vocal analysis pilot project is presently underway and looks promising. Metabolic problems can be detected, but attempts to reverse such issues as overweight have been unsuccessful.

It is not recommended that sound therapy be used for emergency situations such as poisoning, traumatic bleeding, broken bones or issues analogo-

us to heart attack and appendicitis unless no other treatment is possible. Sound therapy is more appropriate for diagnosis, prediction and the reversal of non-emergency symptomatic conditions. For instance, it would not be suggested that sound therapy be used to set a broken bone, but it could be used to accelerate healing, reduce pain and swelling and decrease the duration of recuperation.

Auditory sound therapy should be used as a first resort when any learning, hearing, language, speech or behavioural problems are suspected. Sound therapy can be used as a diagnostic tool with a great deal of accuracy.

**According to the word of
God and the mandates of
science, everything is
frequency—and frequency is
everything.**

X	DELTA	THETA	ALPHA	BETA	C-3	C-2	C-1	Middle C	NOTE
1.02	2.04	4.08	8.17	16.35	32.70	65.40	130.81	261.63	C
1.08	2.16	4.33	8.66	17.32	34.64	69.29	138.59	277.18	C#
1.14	2.29	4.58	9.17	18.35	36.70	73.41	146.83	293.66	D
1.21	2.43	4.86	9.72	19.44	38.89	77.78	155.56	311.13	Eb
1.28	2.57	5.15	10.30	20.60	41.20	82.40	164.81	329.63	E
1.36	2.72	5.45	10.91	21.82	43.65	87.30	174.61	349.23	F
1.44	2.89	5.78	11.56	23.12	46.24	92.49	185.99	369.99	F#
1.53	3.06	6.12	12.25	24.5	49	98	196	392	G
1.62	3.24	6.48	12.97	25.95	51.91	103.82	207.65	415.3	Ab
1.71	3.43	6.87	13.75	27.5	55	110	220	440	A
1.82	3.64	7.28	14.56	29.13	58.27	116.54	233.08	466.16	Bb
1.92	3.85	7.71	15.43	30.86	61.73	123.47	246.94	493.88	B

Particularly when the symptoms are varied, obscure or non-discriminating, sound therapy can be predictive of issues before they become apparent.

Vocal sound therapy has become a very useful tool for pain relief especially when the use of medication is contraindicated.

PREVENTIVE VALUE OF SOUND THERAPY

Nutritional assessment can be very expensive, but by using vocal assessment it becomes an inexpensive, time-saving, preventive measure.

The identification of seven-year-long problem was solved recently when a nutritional analysis revealed that all components relating to the Krebs cycle were under stress. This shows that sound therapy can provide indicators that would prompt medical attention.

Indications that fibromyalgia may be due to stored drug deposits (prescription or otherwise) in the muscle tissues, are a result of BioAcoustic nutritional vocal analysis. This experimental aspect of sound therapy shows promise as a diagnostic tool.

BioAcoustics is particularly helpful as a supplement to sports medicine and traumatic structural injuries. As a complement to occupational, physical and chiropractic therapies, it shortens and facilitates the exercises.

The condition known as TMJ (Temporomandibular Joint Disorder) has responded particularly well to BioAcoustic methods.

Although the foundational principles of BioAcoustics are not yet completely established, the results are undeniable. From the preliminary research it appears that the sound presentations

cause entrainment of brain-wave frequencies. In turn, these frequencies act as a support to the body until it can maintain them independently.

At present, the scope of practice and treatment of sound therapy is only limited by the number of practitioners and the acceptance by the insurance underwriters. Most practitioners have a waiting list. It wasn't until recently that computerised equipment allowed for the inclusion of BioAcoustic assessment as a complementary tool to conventional wellness practices. These recent improvements in assessment time and presentation delivery will allow sound therapy the potential to become a standard diagnostic tool.

The Tomatis Method is used in 180 facilities in 15 different counties. The Tomatis Centre headquarters are located in Paris, France. The most well-known US centre is located in Phoenix, Arizona and is under the direction of Billie M. Thompson, Ph.D.

BioAcoustics facilities are located in six countries, with many positioned around the US. At present, 1,500 persons have been trained, about 40 per cent of them being medical practitioners, but not all of these individuals are practising.

RESEARCH DISCLOSURES

Most of the present-day research in sound therapy using voice spectral analysis has been done by a corporation called Signature Sound Works, Inc., aka Sound Health Alternatives International, guided by the very unusual healing ability of the founder (this author).

My first publication concerning this work was published as a graduating thesis in 1982. In that initial paper I was very cautious about revealing that I had a very unusual ability. I could hear

sounds emitted from people that were in a range not normally perceived. A hearing test revealed that I could hear well above the normal range and, equally surprising, I could produce sine waves with my voice. The production of sine waves by anything other than a machine is quite unusual. I was tested in three labs, including one at Wright Patterson Air Force Base, to prove the point that my voice was unique.

I was cautioned by my professors and colleagues to keep this information to myself. How could I be hearing sounds being emitted from the side of a person's head? After all, there was nothing there to create a sound and certainly the ear was incapable of making sounds. Later, Wendell Brown of Johns Hopkins University published several papers indicating that the ear is capable of emitting a sound that he calls "oto-acoustic emissions". He assumed that the stapes muscles in the ear were responsible. A recent work by James P. Cowan, titled *Handbook of Environmental Acoustics*, states that the actual formation of the ear canal only lends itself to creating sounds that range from F to A. The sounds that I heard contained a full range of notes over several octaves.

From the preliminary research it appears that the sound presentations cause entrainment of brain-wave frequencies. In turn, these frequencies act as a support to the body until it can maintain them independently.

It is my assumption that the brain creates frequencies that are amplified through the brain fluids. (Liquid is a highly efficient sound-conductive source.) The sounds created by the brain are then amplified by the ear, and this is what I hear.

From being able to hear the sounds being emitted, we were able to use trial and error to correlate sound with diseases and muscles. Being able to have clues that sent us in the right direction made the entire field easier to develop.

The work with Signature Sound and BioAcoustics has been made possible because of this talent that was at first perceived as very esoteric. Today, modern computers and electronics have made it possible for the ideas of BioAcoustics to be moved from the realm of disbelief and fear to the realm of repeatable science and technology. My goal has been to educate, because I believe that what people don't understand, they fear. It has been my mission to prove that what I am capable of doing can be duplicated through technology. I feel very fortunate to have been able to contribute many of the clues that have made this particular branch of sound therapy possible.

I will continue to work with those persons who are non-verbal and hopefully, in the very near future, we will be able to develop a microphone that will determine the body's frequencies without the need for voice spectral analysis.

Eventually we will be able to use this technique with animals and, in the not-too-distant future, to help our environment.

FUTURE PROSPECTS

Sound therapy was originally developed to consider the potential applications for the frequencies thought to emanate from living systems.

Now that the foundation work is completed, the possibilities are far more extensive than previously imagined. Areas of development for sound therapy are being explored. As both branches of sound therapy have different potential applications, these are listed separately.

Continued on page 91

FINNISH SCIENTISTS DISCOVER ARTIFICIAL GRAVITY

by Martin Gottschall ©1997

Information about this discovery has come to us from two sources. The November 1996 issue of the Australian International UFO-Flying Saucer Research, Inc. Newsletter carries an article on page 15 which appears to have been taken straight from *Skywatch*, 8 September 1996, and is entitled "Antigravity from Finland". The other source is an article that appeared in the *Sunday Telegraph* (UK) on 1 September 1996 (page 3), obtained off the Internet by our treasurer, Lee Earle.

To all appearances, this is a genuine report of an anomalous discovery with stupendous implications, and will be treated as such in this article. From what we know about the UFO cover-up and, in particular, the secrecy over advanced technology, this may well be all we will hear about this discovery if it is absolutely genuine and real. So we might as well make the best of what we have now, rather than wait for more.

It is apparent that the *Skywatch* article is itself based on the *Sunday Telegraph* article, or that both share a common source, because the wording is virtually identical. I reproduce here all the wording which describes the discovery, but leave out most of the paragraphs or sentences which speculate on the possible significance and application of this discovery. We know its significance well enough.

THE REPORT

"Scientists in Finland are about to reveal details of the world's first anti-gravity device. Measuring about 12 inches across, the device is said to reduce significantly the weight of anything suspended over it.

"The claim—which has been rigorously examined by scientists, and is due to appear in a physics journal next month—could spark a technology revolution...

"The *Sunday Telegraph* has learned that NASA, the American space agency, is taking the claims seriously and is funding research into how the anti-gravity effect could be turned into a means of flight.

"The researchers at the Tampere

University of Technology in Finland, who discovered the effect, say it could form the heart of a new power source, in which it is used to drive fluids past electricity-generating turbines.

"According to Dr Eugene Podkletnov, who led the research, the discovery was accidental. It emerged during routine work on so-called 'superconductivity', the ability of some materials to lose their electrical resistance at very low temperatures.

"The team was carrying out tests on a rapidly spinning disc of superconducting ceramic suspended in the magnetic field of three electric coils, all enclosed in a low-temperature vessel called a cryostat.

"One of my friends came in and he was smoking his pipe,' Dr Podkletnov said. 'He put some smoke over the cryostat, and saw that the smoke was going to the ceiling all the time. It was amazing—we couldn't explain it.'

"Tests showed a small drop in the weight of objects placed over the device, as if it were shielding the object from the effects of [the Earth's] gravity—an effect deemed impossible by most scientists.

"We thought it might be a mistake,' Dr Podkletnov said, 'but we have taken every precaution.' Yet the bizarre effects persisted. The team found that even the air pressure vertically above the device dropped slightly, with the effects detectable directly above the device on every floor of the laboratory.

"In recent years, many so-called 'anti-gravity' devices have been put forward by both amateur and professional scientists, and all have been scorned by the establishment. What makes this latest claim different is that it has survived intense scrutiny by sceptical, independent experts, and has been accepted for

publication by the *Journal of Physics D: Applied Physics*, published by Britain's Institute of Physics.

"Even so, most scientists will not feel comfortable with the idea of anti-gravity until other teams repeat the experiments. Some scientists suspect the anti-gravity effect is a long-sought side-effect of Einstein's general theory of relativity, by which spinning objects can distort gravity.

"Until now it was thought the effect would be far too small to measure in the laboratory. However, Dr Ming Li, a senior research scientist at the University of Alabama, said the atoms inside superconductors may magnify the effect enormously. Her research is funded by NASA's Marshall Space Flight Center at Huntsville, Alabama, and Whitt Brantley, the chief of Advanced Concepts office there, said, 'We're taking a look at it, because if we don't, we'll never know.'

"The Finnish team is already expanding its programme, to see if it can amplify the anti-gravity effect. In its latest experiments, the team has measured a two per cent drop in the weight of objects suspended over the device—and double that if one device is suspended over another.

"If the team can increase the effect substantially, the commercial implications are enormous."

HOW THE ANTI-GRAVITY DEVICE WORKS

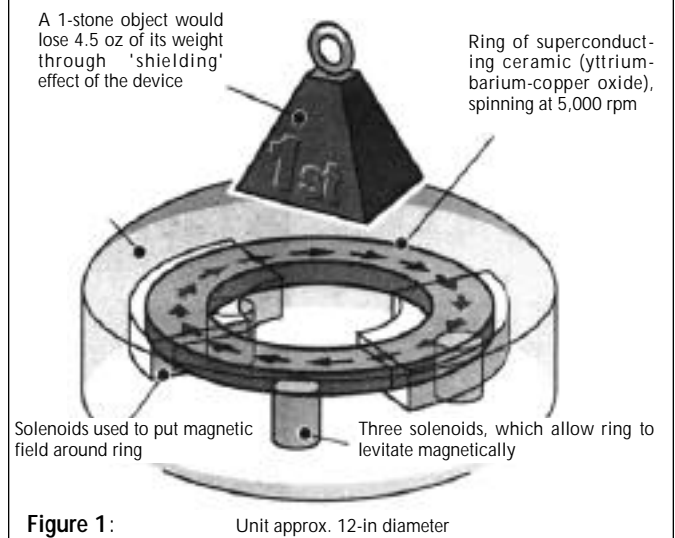

DESCRIPTION OF EXPERIMENTAL APPARATUS

The Internet version includes a diagram (which was presumably published by the *Sunday Telegraph*) of the apparatus used in this experiment. The diagram shows a ring-shaped ceramic superconductor spinning at 5,000 rpm about a vertical axis of rotation (see Figure 1). This ring is about 8 inches (200 mm) in diameter on its outside, and possibly 5/16th inch (8 mm) thick. Three solenoids are positioned under the ring and produce a magnetic force which supports its weight (levitates the ring). The same solenoids were probably used to levitate and spin up the ring before it became superconducting. More on this later.

Another two solenoids seem to wrap around the ring. They were "used to put magnetic field around the ring". Since the discovery was accidental, we infer that this apparatus was designed for a different purpose. We need to speculate on the original purpose of these experiments in order to appreciate better exactly what electromagnetic effects were being produced that might have led to the gravitational effect.

CURRENT RESEARCH ON SUPERCONDUCTORS

Superconductors are a technical innovation with tremendous commercial potential; hence the huge research effort by many scientists. Much of this work is directed at overcoming two problems that stand in the way of this commercial application. One is that the temperatures have to be very low. Until recently, a few degrees above absolute zero were needed

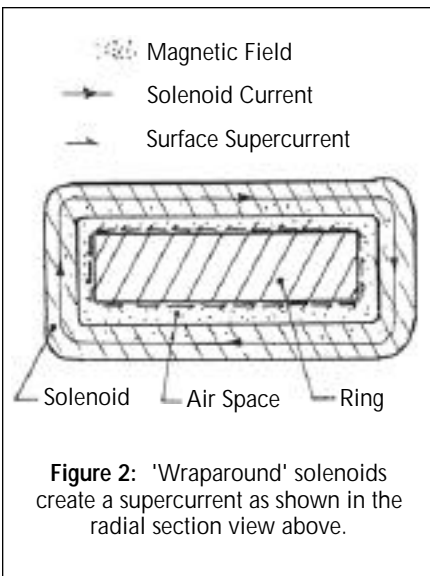

to create superconductivity. In recent years, a class of materials was found which became superconducting at tens of degrees absolute—a tremendous improvement, but not quite enough.

The second problem relates to the amount of current which a superconductor can carry. When a material becomes superconducting, a strange thing happens: all external magnetic fields are expelled from the body of the material. If we cause a current to flow in a superconducting wire, only the outer surface of the wire will carry current; the bulk of the wire does not participate at all. This means that the supercurrent is extremely intense, and a point is quickly reached where this current intensity destroys the superconducting condition.

From the nature of the apparatus given in Figure 1, it seems that the experimenters were testing the ceramic material for its ability to sustain a certain current intensity. The gravitational effect might therefore have been due to the three levitating solenoids, or the two 'wraparound' solenoids, or the start-up procedure, or a combination of any or all these things.

ANOMALOUS OBSERVATIONS

Before looking at these processes in more detail, let us consider exactly what was observed. The outside of the cryostat was probably cold due to imperfect insulation, and the air in contact with it would have been cooled, too, and descended towards the floor. When the visitor made some of this air visible with smoke, the scientists were surprised to see the air rising towards the ceiling. Being a little warmer than the surrounding air, the smoke rose, but near the cryostat the cooling effect of the apparatus predominated. The experimenters were no doubt surprised to see the descending air, as revealed by the smoke.

They measured the pressure of the atmosphere above the device and found it to be a little lower. We are not told how much change was measured, but a pressure reduction was also obtained on other floors of the laboratory, directly above the device. This tells us the effect had a long range.

The effect of a bar magnet drops off as the cube of distance, i.e., very rapidly. If we had placed a 12-inch-long bar magnet where the device was, its effect on the next floor would have been only 1/500th of the effect near the magnet. Natural gravitational fields fall off with the square of distance, i.e., not so rapidly. The field around

a single electric charge behaves the same way. If a 12-inch sphere had been charged up, the effect of its field on the next floor would have been about 1/60th of the effect near the sphere.

The Finnish experimenters will no doubt have determined how the influence drops off with distance, both vertically and horizontally, but they have not said. We might assume that it either falls off as the inverse square, like natural gravity, or as the inverse distance, as with radio waves emanating from an antenna. Had the drop-off been more rapid, it would have been quite difficult to measure over a distance of several floors.

The experimenters also suspended an object from a weighing device and observed a 2% reduction in its weight. To eliminate non-gravitational effects, this object would have been a non-magnetic metal like copper, lead or aluminium. They would have earthed the device and the weight to eliminate electric forces, and measured the weight with a device like a spring balance which does not depend on gravity for its action.

The last item of information is that when two devices were stacked one above the other, the weight reduction was doubled. This tells us that this influence is linear and allows us to predict that by either intensifying the action, or by stacking up devices, or both, any degree of gravitational effect will ultimately be achievable.

Nothing was said about the effect below the apparatus. Was there an effect there also? Was it to reduce weight or increase it? The fact that nothing was said would seem to imply that below the device there was also a weight reduction, and that it

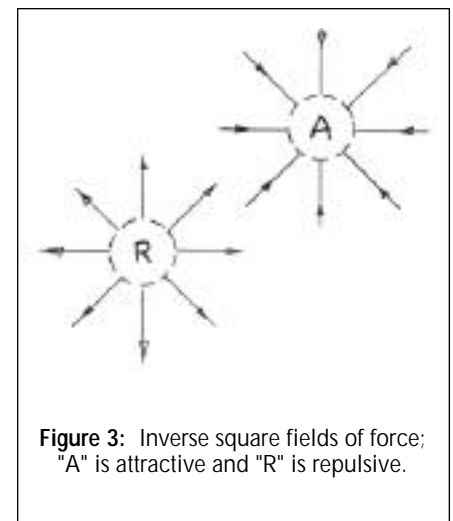

NEWSCIENCE NEWSCIENCE NEWSCIENCE

diminished with distance in much the same way as above. But we don't really know. The experimenters might have wanted to keep something up their sleeves, too.

THE LIKELY EXPERIMENTAL PROCEDURE

Let us now consider the electromagnetic events of this experiment. First the ring is cooled down to near its superconducting temperature. I don't know much about the electrical properties of the ring material, but will assume here that it was able to conduct electricity, like metals do, before it became superconducting. If that was not the case, then the superconducting material would have been applied as a thin layer over a metal ring such as iron, and the metal would have been used to levitate and spin up the ring before the superconducting condition took over.

Ordinary conductivity is needed for the three levitating solenoids to lift and spin up the ring. This action is just like what happens in an ordinary AC induction motor—the type invented by Tesla. One-hundred cycle, three-phase power might have been used to do this. When excited by three-phase power, the solenoids produce the same effect as a pair of vertical bar magnets rotating under the ring at 6,000 rpm. Because of the electrical resistance in the ring, a kind of electrical friction is produced which drags the ring around with them. At the same time, the ring is repelled upwards and levitated.

As the ring is brought up to speed, it probably cools more rapidly due to gas turbulence. At 5,000 rpm it becomes superconducting. When this happens, the frictional effect disappears but the levitating effect remains. The three-phase AC can now be switched off and replaced by an equivalent DC current in all three solenoids to maintain levitation.

With the ring up to speed and superconducting, it is time to perform the current-intensity measurement. At this stage the disc is slowing down due to friction from the gas inside the cryostat, which is probably helium. This could take minutes, and hence allow ample time for the gravitational effect to be observed. During this phase, the two wraparound coils are energised with either AC or DC, probably DC. The entire ring is enfolded by this effect, and the field tends to centre the superconducting ring in the solenoid. Thus it can also be used to levitate the ring, and current to the three solenoids can be switched off alto-

gether. Figure 2 shows the current flow pattern in the ring that is associated with these coils.

REPLICATING THE EXPERIMENT

The purpose of the above examination of this experiment is not only to understand what might have happened, but to help any interested researcher to repeat the experiment. Although the original experiment was performed with a superconductor, it is not immediately obvious that this feature is essential. Certainly, similar current flow patterns can be produced in ordinary conductors. Thus, since the superconductor may be hard to obtain, at least some meaningful work can be done without it.

It is entirely possible that the superconducting property is an essential ingredient of the gravitational effect—and not just any superconductor but particular ones, such as the materials used by the Finnish team. If that is the case, then they have the field very much to themselves at this time. They may not even know exactly what it takes to produce the gravitational effect—only that their apparatus is somehow doing it.

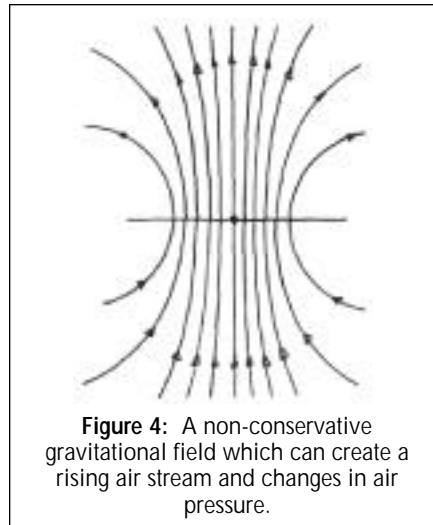

Figure 4: A non-conservative gravitational field which can create a rising air stream and changes in air pressure.

When the promised paper appears, we will know more about what may be required to produce a gravitational effect. I have checked copies of this publication up to November 1996 but have found no reference to this work. This is not unusual. It could take the Finns a year to satisfy the reviewers and examiners of this publication that their work is genuine, and put their report into a form acceptable to its editors.

Knowing what we know about 'the cover-up', our concern is that if the discovery is genuine, the report of the Finnish team may never appear in print at all.

NATURE OF THE GRAVITATIONAL FIELD OBTAINED

There is enough information in the *Sunday Telegraph* report to allow us to say something about the kind of field of influence which the Finnish team observed. Figure 3 shows a natural inverse square attractive field, and an inverse square repulsive field. So far, the latter field has not been observed.

If the experiment had produced an inverse square repulsive field, there would have been a weight loss above the device, a weight increase below it, and a reduction in air pressure near it. However, no air movement would have been produced because all changes in weight would have been balanced exactly by the change in pressure. Such a field would be called "conservative". In a conservative field, an object taken around any path in this field, but brought back to its starting point, would neither lose energy to the field nor gain any energy from it. The experimenters made a point of saying that the air above the device was constantly rising. This means that the field was not conservative.

Figure 4 shows a field which can produce a pressure reduction as well as air movement. This is just the kind of field that various researchers have postulated as required to explain the behaviour of UFOs (see, for example, Aimé Michel's *The Truth About Flying Saucers*, p. 211). To interpret the field, the reader need only assume that, at each point, the force on any object there acts along the local field line in the direction given by the arrows; and that the more crowded the lines, the stronger the force.

In Figure 4 there is a weight reduction above and below the apparatus, and the apparatus itself should show the greatest reduction. Around the apparatus the effect is mostly vertical and fairly uniform—an ideal propulsion field.

There is talk in the article about generating energy by harnessing the weight-loss effect. This is entirely possible in the field of Figure 5, but the energy may not be free. This energy may have to come from the spinning disc or the solenoids. Until we have proof to the contrary, it is unwise to assume that just because the field is not conservative, energy is therefore not conserved in the overall action of the field. Magnetic induction fields are not conservative either, but energy is certainly conserved in their action. We have here an experiment based almost wholly on magnetic induction. To find a non-conservative

NEWSCIENCE NEWSCIENCE NEWSCIENCE

gravitational field is not that surprising, but to find that energy was not conserved would really be new.

POSSIBLE APPLICATION TO POWER GENERATION

A 2% reduction in weight is quite enough for producing substantial amounts of power. In the laboratory, air was rising over the apparatus, spreading horizontally at the ceiling, and descending at a distance from the axis of the spinning disc. If a pipe filled with, say, water, were made to trace out that path, it would move just like the air, and a turbine could extract energy from the flow.

An even simpler solution is to make a large wheel with a heavy rim and position it with its axis horizontal so that one side of its rim is just above the device, while the other side is as far away as possible (see Figure 5). The wheel could be placed inside an evacuated container to reduce air friction. If the rim of this wheel weighed 1,000 kg and moved with a speed of 500 m/s (the kinds of speeds we have in gas turbines), a 2% reduction in the weight of the rim would generate 100,000 watts of power—about the output of a medium-sized car engine at full throttle.

Elsewhere in this article it was noted that this energy had to be coming from somewhere, most probably the spinning superconductor disc or the solenoids, or all of them. In this case, the energy would be no use as a source of primary power.

However, there are significant engineering applications even then. Firstly, if the wheel motion is reversed and it is driven, we are then pumping energy into the device. This could be one way of intensifying the field, or of maintaining it in ways

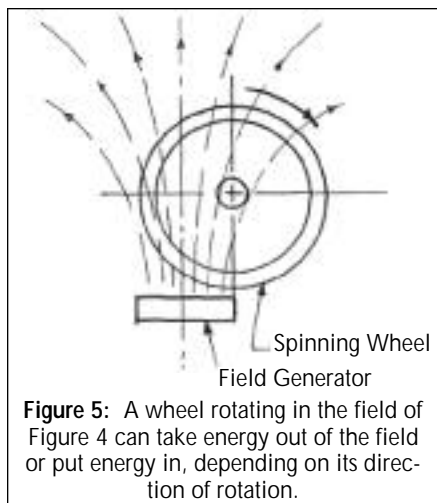

Figure 5: A wheel rotating in the field of Figure 4 can take energy out of the field or put energy in, depending on its direction of rotation.

that might be more convenient or more efficient than the various electrical inputs.

The device could also be a mechanical transformer. One wheel could pump energy in, while another could take it out. The two wheels could be running at different speeds, giving the effect of a gearbox—possibly one that is near 100% efficient.

At this stage we don't really know what the effect might be of pumping energy in. Since one possible effect is to intensify the field, one would expect the experimenters to waste no time in conducting some spinning-wheel tests, especially since they are relatively easy to do.

EXTRATERRESTRIAL SOURCES ON ARTIFICIAL GRAVITY

Gravitational propulsion is dealt with in the UFO literature, but two sources which I believe all researchers should keep in mind are those from George Hunt Williamson and Daniel Fry.

On page 83 of *The Saucers Speak*, Williamson conveys the following message given by ETs on 19 September 1952:

"The four great primary forces are: static magnetic field; electrostatic field; electromagnetic wave; resonating electromagnetic field. Your scientists do not understand the last one mentioned."

On page 51 of *The White Sands Incident*, Fry quotes his ET contact as saying on 4 July 1950:

"You are familiar enough with electro-dynamics to know that a moving electron creates a magnetic field. The tremendous surge of electrons through the force-rings produces a very strong magnetic field. Since the direction and amplitude of flow can be controlled through either ring, and in several paths through a 'single' ring, we can produce a field which oscillates in a pattern of precisely controlled modes. In this way we can create magnetic resonance between the two rings, or between several segments of a single ring.

"As you also know, any magnetic field which is changing in intensity will create an electric field which, at any given instant, is equal in amplitude [this should perhaps read "phase". Auth.], opposite in sign, and perpendicular to the magnetic field. If the two fields become mutually resonant, a vector force will be generated. The effect is similar to, and in effect identical with, a gravitational field. If the center of the field coincides with the craft's center of gravity, its only effect will be to increase the inertia or mass of the craft.

"If the center of gravity does not coincide with the center of force, the craft will begin to accelerate towards that center. Since the system which creates the field is part of the ship, it will of course move with the ship, and without interruption it will continue to generate a field whose center of attraction is just ahead of the ship's center of gravity, so the ship will continue to accelerate as long as the field is generated.

"Note that this system does not involve 'free energy' or what your people refer to as perpetual motion...

"To slow or stop the craft, the controls are adjusted so that the field is generated just behind the center of gravity so that negative acceleration will result."

By the time these messages were given, government authorities already had in their possession crashed UFOs and the means to discover their method of propulsion. This information was being denied to the general public and the scientific community. The ETs, as they often do, were evening the scales a little in our favour. Unfortunately, UFO researchers and the scientific and technical communities were just too blind and deaf to benefit from this effort. It is not too late yet: they might still redeem themselves. The Finnish discovery is just the latest in a series of 'nudges' which could turn them around.

WHY DID THE FINNISH TEAM ISSUE A PRESS RELEASE?

The researchers at Tampere University had already spoken to British scientists by the time they gave this press release. They could have had several reasons for issuing this press release:

- The experiment is relatively easy to duplicate in various other superconductivity laboratories around the world, and they wanted to secure their priority.
- Negotiations with other scientists were breaking down and publication in a suitable scientific journal was becoming doubtful.
- The cover-up merchants were moving in and they saw a press release as a way to keep the discovery in the public domain.
- They might have suspected or known that secret gravity research has already progressed way past this point, and the best use of their discovery was to bring it into the public domain.

This article also appeared in *UFO Encounter* (Jan/Feb 1997), published by UFORQ, PO Box 222, 50 Albert St, Brisbane Qld 4002, Australia, phone +61 (0)7 3376 1780.

BRIGHT SKIES

Top-Secret Weapons Testing?

Strange fireball events have been witnessed in many remote parts of Australia recently.

With the meteor theory ruled out, could these moving plasmoids be part of some military secret-weapons program, or even the work of UFOs?

Part 1

by Harry Mason, B.Sc., M.Sc.
©1997 All Rights Reserved

1313 Armstrong Road
Jarrahdale WA 6203, Australia
Phone: +61 9 525 5999
Fax: +61 9 525 5944
E-mail: orbitx@ois.com.au

My research into the subject of Australian fireballs began about two years ago in early 1995. A colleague and friend, John Watts, of geological consultants Mackay & Schnellmann Pty Ltd, asked for my opinion on earthquake risk in an isolated area of the Eastern Goldfields of Western Australia (WA). John knew of my long experience in the Laverton region, conducting geological and geophysical field exploration surveys there for gold mineralisation—hence his approach to me for scientific advice concerning an odd series of events that occurred in this area of WA in May 1993.

THE BANJAWARN FIREBALL EVENTS

Whilst visiting a small underground gold-mine John had noticed a *Kalgoorlie Miner* newspaper article, dated 1 June 1993, attached to the barracks' kitchen fridge door. This reported that on 28 May 1993 at 23.03 hrs a meteor fireball was seen by several observers to be flying from south to north between Leonora and Laverton. This was immediately followed by a significant 3.9 Richter-scale earthquake—picked up by 23 seismic receivers around WA and the Northern Territory (NT). Ed Paul, a geophysicist at the AGSO (Australian Geological Survey Organisation) Mundaring Seismic Observatory near Perth, had received several telephone calls from the public, as had the Laverton Police. Ed had reasoned that there was a possible connection between the meteor fireball and the quake due to an impact with the ground.

The small gold-mine (the Alycia mine) experienced this quake event as underground three-inch steel pipes sheared clean in half and drives and shafts collapsed. My friend John has done a considerable amount of earthquake risk assessment during his consulting career and thought that this damage pattern was more like instantaneous blast damage, as is normally caused by big explosions, rather than standard earthquake damage. The key to this was the underground damage, and the type of damage caused, in comparison to the more normal quake mine damage which is usually limited to surface building collapse caused by quake-induced seismic ground waves.

Many observers reported that the fireball passed overhead making a pulsed roaring noise, similar to a very loud road-train diesel engine, and that after the seismic wave hit they heard a huge, long-drawn-out explosion—similar to a very major, but long-drawn-out mine blast, but somehow peculiarly different. (Note: The seismic ground wave moves much faster than the speed of sound from an explosion).

At the time we reasoned that Ed Paul was probably correct and that a meteor fireball (a bolide) could have impacted explosively into the ground and caused the apparent "earthquake" by impact or by airburst-explosion shock-wave induction. This area of WA has had no recorded quakes since seismographs were first installed in 1900, nor Aboriginal racial memory of any quakes.

As such an impact event is a major geological curiosity, often observed in the Earth's geological record but rarely recorded as occurring in human history, we decided to embark upon a private research project to document the event—leading, we hoped, to scientific fame and glory. We did not then appreciate just where this research work and interest would lead...

I visited the area in May and June 1995 and began to interview, by personal visit or telephone, the inhabitants of a 300-kilometre-radius area centred upon Laverton. This Eastern Goldfields region of WA is semi-desert and very isolated with an extremely low population density. It contains several very large sheep stations, a couple of small gold-mining towns (Leonora and Laverton), plus several isolated gold-mine sites, a few gravel or dirt roads, a lot of thick mulga bush and gum-tree scrub vegetation with some sand dune fields and spinifex-grass cover.

I hired a light plane so I could visit outlying stations and Aboriginal settlements to search for eyewitnesses and for "ground zero". This took some three weeks. A summary of all currently available witness data follows:

A large orange-red spherical "fireball" with a very small bluish-white conical tail had flown from low down in the south over observers to the north. Some observers reported that the fireball was cylindrical in form and more yellow-blue-white in colour. It was heard as a pulsed, roaring or loud diesel-engine sound—well before it passed overhead. It dropped off no glowing fragments, and had no long, luminous tail or sparks—as is common meteor activity. Its speed was similar to a 747 jetliner or a fast jet-plane and was obviously less than the speed of sound since loud noises were heard in advance of its arrival.

The sounds heard before the "object" arrived were most definitely *not* "normal" electrophonic sounds as have been quite commonly reported from historical meteor fireball events. Such electrophonic sounds are experienced as weird "pings" and "whees" of low-volume intensity and are not fully understood at this time, but they are believed to be due to hertzian electromagnetic (EM) waves produced in the bolide plasma trail and propagated at the speed of light to the observer—in advance of the bolide. These sounds are thought to couple harmonically with the inner ear or cause nearby objects to vibrate sympathetically, thus producing the characteristic low-volume sounds. No sonic booms were reported, and no observer believed that any explosion was heard until the object had got to ground level, or very nearly so, behind low hills or treeline cover and then exploded or impacted.



The fireball object flew apparently parallel to the Earth's curvature in a long, "nap-of-the-Earth" arcing trajectory at low altitude (possibly some 1,000 to 2000 metres), from low down on the southern horizon—not with a "normal" meteor's inbound high-angle, high-altitude trajectory.

The fireball lit up some observers and their vicinity as it passed overhead. Its flight trajectory was observed over a distance of least 250 km—although it probably had a much longer flight path well out over the southern Indian Ocean from Antarctica. It then appeared to arc down towards the ground before it disappeared out of sight behind trees or low hills.

This was followed by a near-blinding, massive high-energy burst of blue-white light that rippled for about three to five seconds. This lit up the windless, cloudless, moonless night sky as if it were daylight. Observers could see for some 100 km in every direction at ground level—"as clear as day". The energy intensity involved in this light flash was similar to the light flash generated by a significant nuclear blast, and in many respects the incident strongly resembled a night-time nuclear test.

A huge red-coloured flare then shot vertically skywards for some considerable distance (several kilometres?). This event was immediately followed by a massive seismic ground wave that hit the observers nearest to "ground zero" such that rocks and beer cans vibrated off tables and the ground shook so violently that persons tending a campfire fell over.

Then followed a very loud, major explosive blast that was heard over a 250 km by 150 km corridor. Minor quake damage was reported as far as 150 km southeast of ground zero (the other directions, excepting Leonora to the southwest, being largely uninhabited). Located that night in Laverton was an engineer—with Gulf War experience of missiles and aircraft breaking the sound barrier—who described it as "definitely a major explosive concussion-wave blast [not a sonic boom], similar to, but *much* bigger than, a normal open-pit mine blast".

A large, deep-red-orange-coloured hemisphere of opaque light, with a silver outer-shell lining, then rose from ground level to hover around over the "ground zero location". This structure, when fully developed, was approximately three times the size of a typical Goldfields setting Moon, as seen by observers located 30 to 50 km away (in other words, it was *very* big), and it "bobbed around a bit for *nearly two hours* before disappearing suddenly—as if someone threw the light switch off".

This "half-soup-plate structure", looking like a "deep-red, very large and half-set Sun", was seen by two observers from widely separated locations, one at the Banjarnaw station buildings and one at the Deleta station buildings. Dogs at both locations went totally berserk, whining and howling and attempting to get off their leads whilst the aerial light hemisphere was up. Presumably there was an ultrasonic or EM wave propagation to which the dogs were extremely sensitive.

Aboriginal prospectors who were camped very near to ground zero at the Freeman's Find gold prospect were extremely spooked by the event, believing that it was "the end of the world". Some of them thought that they had witnessed a "jumbo jet" crash behind a range of low hills. They gathered their swags (bed rolls) close together as they were too scared to sleep apart. In the morning they climbed a hill to look for fires in the distance but could see no smoke. They quickly departed the area for the safety of Leonora.

One Aboriginal stockman observer, located at the Banjarnaw station buildings, believed that he was witnessing a fairly slow-moving "UFO" and became very worried that they were going to land and abduct him and his two companions—since it flew directly at him and then passed, very noisily, low overhead before going into

its final downwards-arcng plunge.

Almost exactly one hour after the first big event, three observers located at the Banjawarn station buildings saw a second, much smaller fireball which they described as being more of a blue-green-white colour. It appeared to rise from ground level, but definitely rose from behind distant trees well south of the station perimeter, and then flew to the north in a high mortar-shell-type arc before coming down to ground level behind distant bush. Its flight path was divergent to the north-northeast when compared to that of the first major fireball event of that night.

This later event then created a second but very small explosion and concomitant minor ground shake, similar to the first event but much smaller in size and with no resultant rising hemisphere of opaque light. A prospector located north of the Mulga Queen Aboriginal settlement also reported seeing parts of this second event.

This second event does not appear to have been of sufficient enough magnitude to register on AGSO seismographs. However, analysis of the best AGSO seismic records by USGS (US Geological Survey) energy conversion equations suggests that the energy involved in the first main event quake was probably of the order of one to two kilotonnes of TNT equivalent. The blast itself was probably bigger, as not all such explosive energy is transmitted efficiently into the ground and along the Earth wave path to the seismic observatories.

The main fireball eyewitness "explosion ground zero" was located near to the northern edge of Banjawarn station, whereas the calculated AGSO quake epicentre fix was close to the southern perimeter of Banjawarn station, the difference reflecting the difficulties involved in calculating accurate quake epicentres from remote seismographic locations.

In spite of the excellent eyewitness "ground zero impact" cross-fixes, a considerable time in the air in a Cessna-172 failed to find any crater or ground anomaly of any kind there or anywhere else in a 300-km-diameter search area. Ground and air examination of the nearby Celia fault lineament produced no evidence of any movement on this structure.

Banjawarn is arguably the most isolated station area in the Eastern Goldfields region of WA. This sheep station has gained notoriety since its purchase the same year (1993) by the Japanese Aum Supreme Truth (Aum Shinrikyo) sect—of 1995 Tokyo subway gas-attack fame. Research soon showed that a Japanese Aum Supreme Truth sect representative—deputy leader Hayakawa—had been inspecting sheep stations for sale, around and including Banjawarn, in early April 1993.

Hayakawa initiated purchase procedure for Banjawarn in late April 1993, desiring to "conduct experiments there for the benefit of mankind". The station actually changed hands when papers were signed and a bank cheque was provided on 1 June 1993—only three days after the fireball event. However, the agreement regarding the sale to the Aum sect was completed on 23 April 1993—some 35 days prior to the fireball event.

As the 28 May 1993 event did not appear to fit any normal mete-

or impact scenario, we began to joke that the Aum sect had probably sent a cruise missile with a pulse jet engine and detonated a nuclear weapon on the uninhabited desert fringe immediately north of Banjawarn station...

Meteors usually travel at hypervelocities, greater than 25,000 mph, and do not normally fly low-speed, "nap-of-the-Earth", low-level (1,000-to-2,000-metre-altitude) trajectories. They usually have long, luminous tails and drop-off fragments, and are not documented as triggering earthquakes.

Pressure changes due to storms (or, possibly, pressure waves created by a meteor flypast) are known to trigger quakes in stressed-plate regions of the crust, but this region can hardly be assigned a high-stress fault signature, given the total lack of such quake events in human memory. It is a very stable Archaean Age cratonic shield area, with the nearest location demonstrating quake activity being located in the Fraser Ranges, some 500 to 600 km to the south, east of Norseman.

In response to recent ABC radio interviews given by the author, three truckies reported seeing yet another fireball soon after starting work at 5.00 am one day (exact date unknown) in May or June of 1993. Their "Moon-sized" fireball flew from south to north at low level (some 1,000 metres) with a high-speed jet-plane velocity. It was yellow-orange-red in colour and had a very small blue-white tail. It lit up the early morning dark sky in an intense blue-white light flash that silhouetted the countryside as it headed immediately west of Laverton directly for Banjawarn station. As the truckies were sitting next to loud diesel engines of their own, they do not know if this third Banjawarn fireball made any pulsed, roaring noise.

This third fireball held a course that would not only pass over Banjawarn but might ultimately have reached the Exmouth Peninsula in far northwest WA.

Now, for three fireballs to be heading towards Banjawarn is just too much of a coincidence for a meteor-type event. Meteors of this size are very rare events, let alone *three* heading around May-June 1993 into one small space on the Earth's surface at Banjawarn. If we assume that fireball no. 3 was seen at 5.00 am on 29 May 1993—and thus followed fireball no. 1 by six hours, as in, say, a south-to-north-

travelling chain of bolides (rather like the recent Comet Shoemaker-Levy 9 impacts on Jupiter)—we have a problem with the meteor theory, for in that six-hour period the Earth would have rotated 90 degrees about its north-south axis and fireball no. 3 should have come in over East Africa!

OTHER FIREBALL EVENTS IN AUSTRALIA AND NZ

Since the May 1993 event, there have been many other reports (in excess of 1,000 and often of multiple events) concerning aerial fireballs and associated light-energy emissions. They involve exotic, spherical fireballs making diesel freight-train noises (although there are some noiseless variants), flying long trajectories over different parts of Australia. Isolated but similar reports have also originated recently from New Zealand.

These fireballs have been observed in all our Australian states (as late as 4 February 1997), and in many cases have exhibited varia-

The main fireball eyewitness "explosion ground zero" was located near to the northern edge of Banjawarn station...

Banjawarn is arguably the most isolated station area in the Eastern Goldfields region of WA. This sheep station has gained notoriety since its purchase the same year (1993) by the Japanese Aum Supreme Truth (Aum Shinrikyo) sect...

tions on and combinations of the following actions: very-low-altitude; nap-of-Earth trajectories; small-to-nonexistent tails; no fragmentation drop-off; apparent velocity often very slow and commonly less than that of sound; no associated sonic booms; considerable and sudden changes in course, as well as speeding up, stopping dead, reversing course and flying vertically upwards into space; creation of intense vibration of ground and housing during flypast; explosion in massive blue-white arcing light displays with major explosive sound events or silent, intense light-flashes; regular creation of power generation overvoltage outages and other electrical effects.

The Banjawarn case demonstrates a cause-effect relationship with a 3.9 Richter-scale earthquake, and other fireballs have possibly been related on at least two occasions to 3.0 to 4.0 Richter-scale earthquakes in eastern Australia.

If meteors are the source of these observations, then lately we appear to be continually encountering a very odd species of meteor that exhibits a previously undocumented, very exotic behaviour and a very high statistical rate of arrival in Australia, apparently (until recently, i.e., 1996) largely ignoring the rest of the world.

Other possible causes such as natural-gas fireballs, min-min lights and earthquake stress lights may be easily discounted by many aspects of these *multiple* fireball events—but not least because of their usually very-low-energy output when compared to the very large energies involved in these recent Banjawarn fireball incidents.

However, possible scenarios such as off-planet alien UFOs, or Earthbound powers testing new exotic power-plant, military spacecraft and/or EM weapons systems, cannot be so easily discounted.

THE PERTH FIREBALL EVENT

Probably the most spectacular of these fireball events was that which occurred at approx. 2.00 am on 1 May 1995 above Perth, WA. At that time, a large spherical orange-red fireball with a small conical blue-white tail was observed as it flew from the Indian Ocean over Bunbury, in southwestern WA, in a north-northeasterly direction at a relatively high altitude, apparently with a trajectory that was parallel to the Earth's curvature. The altitude of this fireball is open to question as many observers thought that it was not very high in the sky, but newspaper reports later placed it at several kilometres in altitude.

The fireball soon arrived above the eastern side of the City of Perth (population >1 million) and was seen and heard by many eyewitnesses over its 150-kilometre land-flight trajectory. Observers reported that the "object" emitted a loud, roaring, pulsed noise—similar to a diesel freight train—before it arrived, and that it flew at a steady velocity similar to a high-speed jet aircraft. There was no report of a sonic boom.

Whilst moving over the eastern part of Perth, near Midland, the fireball reportedly stopped dead in the sky and the tail inverted through the fireball to point towards the previous direction of travel! Then there was an enormous burst of blue-white arcing light-energy that briefly lit up the city and its suburbs as clear as daylight for many kilometres. In many ways the event was similar in force level to a nuclear blast. A loud, vibrating, massive explosion-cum-seismic wave reverberated around Perth, causing the city buildings to shake and books and objects to fall off shelves.

Several observers reported that, at the instant of the explosion,

four white lights raced apart from the centre of the main "object" and formed a right-angled white cross in the sky. No actual object was seen at any time—just a bright orange-red fireball of light emission and its very small blue-white-light conical tail.

One observer reportedly told the Perth Astronomical Observatory of seeing sparks drop off the fireball during its flight and that it had a long tail or streak of orange colour. All other police and public eyewitnesses reported that the fireball had no tail (or, at best, a rudimentary, very short tail) and that they definitely saw no sparks. They noted that it was spherical or cylindrical in form, as defined by light-energy emission.

About half the city's population, some 500,000 people were estimated to have been woken up by the violence of this explosive, seismic-wave event. The ground vibration wave was picked up by the AGSO Mundaring Seismic Observatory as a paper analogue recording lasting some two minutes, timed at 17.57 UTC, i.e., commencing at 1.57 am WA time.

This event raised some discussion in the WA press over the next few weeks and was generally explained in the media by the Perth

Astronomical Observatory as the explosion of a meteor fireball with a power of *one or more megatonnes of TNT equivalent*, at an altitude of several kilometres. Surprisingly, this event was apparently not widely reported in the world press. One would think that something with a force level equivalent to a large hydrogen bomb detonating above a city like Perth would be worthy of great discussion. Obviously it was not loud enough to wake

Now, for three fireballs to be heading towards Banjawarn is just too much of a coincidence for a meteor-type event.

Canberra...

Reports soon came in of small lights and strange aerial noises that had moved to the north-northeast of Perth towards the small town of Toodyay and beyond, on the night in question. Amateur meteor astronomers spent a considerable amount of time interviewing farmers out that way but no meteor fragments have been recovered to date (December 1996).

Later reports noted that on the same night, some 1,900 km to the north-northeast of Perth, a couple situated on Sunday Island, near One Arm Point north of Broome in the Kimberley region of WA, were woken some time around 3.00 am by a loud, roaring, pulsed diesel-engine noise, "similar to a D9 bulldozer or tank engine", advancing directly towards their front door. This noise rose to a crescendo and books and objects fell from their shelves. The seismic ground-vibration wave and sound event lasted for one to two minutes.

Believing they had experienced an earthquake, the family listened to the early morning ABC radio, but the only story was of the explosive meteor fireball event above Perth. A check of the Mundaring seismic records has shown that no earthquakes of any magnitude at all occurred at Sunday Island or anywhere else in their region that night.

One possible interpretation of these events is that a meteor fireball exploded on contact with the Earth's denser atmosphere high above the east of Perth and that small fragments, including a very large fragment, flew north-northeast over Toodyay, eventually to be heard flying low over Sunday Island in the Kimberley region.

This meteor interpretation ignores the fact of the fireball's slow speed, reportedly similar to that of a jet plane. Due to its roaring sound being heard before it arrived, the fireball apparently travelled at less than the speed of sound at some 750 mph. Most meteors are generally hypervelocity objects flying at many thousands of miles

per hour, often greater than 25,000 mph.

The meteor hypothesis also ignores the strange aerodynamics of an "object" that reportedly stopped dead in the sky, whilst the very small luminous tail inverted through the spherical fireball. Moreover, it ignores the lack of recovered fragments from so great an explosive event, and the accumulated evidence from many other similar fireball events that have occurred throughout Australia in recent years.

Observations of the fireball's flight, or effects associated with the event, cover some 2,000 km in strike across WA and thus allow a reasonably reliable attempt at reconstruction on a globe from a planetary perspective. The trajectory starts somewhere to the south-southwest of Perth—possibly in the Indian Ocean or in Antarctica—and projects north-northeast towards the northeastern coast of Japan and across the centre of the Siberian Kamchatka Peninsula. If continued, the trajectory would cross over northern Alaska and over Arctic Canada to emerge into the Atlantic somewhere near Nova Scotia.

It is interesting that the projected trajectory skims Antarctica along its coast near Enderby Land. At this location is a complex of three research bases: the Japanese bases of Syowa (approx. 40° East) and Mizuho (approx. 45° East and inland), and the former USSR base of Molodezhnaya (approx. 45° East on the coast). Further northwest, the former USSR base of Novolazarevskaya (approx. 15° East on the coast) also lies approximately upon the projected trajectory. The former USSR also has bases ringing the coast of Antarctica at the following approximate locations: 92°E (Queen Mary Land), 105°E (Vostok, inland near the South Magnetic Pole), 163°E (Oates Land), and 224°E/44°W (opposite the Rockefeller Plateau). These bases effectively give a good arc-coverage of the entire globe from the radio transmission viewpoint.

The Kamchatka Peninsula in Siberia was the site of the infamous KAL 007 incident. Recent research by David Pearson, published in his book, *KAL 007: The Cover-up*, concerning this 747 jumbo-jet shoot-down by the Soviets, suggests that KAL 007 was attempting to gain intelligence on a very large transmitter site located in the central part of the peninsula.

It has been suggested by Japanese journalists (*Archipelago* magazine) as well as American scientific researcher Tom Bearden that this Kamchatka transmitter is one of a series of former Soviet EM weapons complexes.

Such weapons are believed to have the ability to transmit explosive and other effects, such as earthquake induction, across inter-continental distances to any selected target site on the globe, with force levels equivalent to major nuclear explosions.

Evidence for the existence of such exotic weapons is given in part in a "Voice of Russia" radio broadcast on their Science and Engineering program of 23 December 1996, where they discussed modern Russian electromagnetic weapons of the microwave plasma variety. The following is a part-transcript of that program, featuring the interviewer Yekimenko and the science authority Boris Belitsky:

Yekimenko: How would a microwave generator be used 'in anger', Boris?

Belitsky: It would be used to fire a plasmoid—that is, a blob of plasma—into the path of an incoming missile, its warhead or an aircraft. The plasmoid would effectively ionise that region of space and, in this way, disturb the aerodynamics of the flight of the missile, warhead or aircraft and terminate its flight. This makes such a generator and its plasmoid a practically invulnerable weapon, providing protection against attack via space or the atmosphere.

Yekimenko: Boris, I hate to ask this question, but still... The generals and scientists who speak of this weapon—they couldn't be bluffing, could they?

Belitsky: Oh, no. This is evident if only from the fact that a few years ago, in 1993, at the Russian-American summit in Vancouver, the Russians proposed a joint experiment in testing such generators—or plasma weapons, as they are called here—as an alternative to the Strategic Defense Initiative, SDI. In such an experiment, which was proposed to be code-named *Trust*, the system would be used to repulse a missile attack. In this way, Russia hoped to strengthen the new climate of post-Cold War security in the world.

These comments of course emphasise that many observed "objects" in the night sky may in fact have no mass associated with them at all, and are actually holograms of light being given off by

slugs of dense EM energy, these being held in place by three or more transmitters' Tesla wave outputs manipulating plasmoid blobs in 3D space.

SILENT FIREBALLS

Another fairly typical (but silent) fireball event occurred in October 1994 at the iron ore mining town of Tom Price in the Pilbara region of Western Australia.

One night in mid-October 1994 a family was having a patio barbecue at about 8.30 pm. They saw a very large red-orange-coloured ball of fire moving at very low altitude directly towards them at a steady, slow, light-aircraft speed (100 mph?) at an altitude of 200 to 300 metres. It was bigger than the Moon in apparent size.

They rang the local police to alert them to a possible aircraft on fire. The two policemen raced outside to watch. By now, half the town (population of some 4,000) was outside

watching the fireball. From front-on it appeared to be a fiery orange-red-yellow colour; from the side it appeared to be yellow-white and pulsing up and down in light intensity (as captured on video).

Our original barbecue observers, by now some 200 metres directly below the "object", reported that it was an intense ball of orange-red fire or plasma with the fire swirling in a spiral pattern and the flames disappearing internally upwards into "a central black hole" or void within the spherical mass of flames. The fireball had no tail and made no noise at all, and there was no ground seismic/noise wave as experienced in many other recent Australian fireball events. It was described as a sort of "implosion ball of flames", with all the fire or flames originating in local space outside the fiery, spherical form, and then being sucked into the centre where they disappeared—"like a moving plasma ball in a local space-time warp around a central black hole". "Never ever seen anything like it before, therefore difficult to describe accurately." (Really aware

About half the city's population, some 500,000 people were estimated to have been woken up by the violence of this explosive, seismic-wave event...

Surprisingly, this event was apparently not widely reported in the world press.

people, these outback mining families!)

The observers said that the fireball took about five to seven minutes to cover the distance from a line of hills west of Tom Price to a line of hills to their east. At this point it flashed a bright blue-white colour that lit up the area; then it took off at very high speed, moving very quickly to the east and disappearing almost instantly. Other observers simply believed that it just disappeared with the intense, bright blue-white light-energy emission flash/explosion, but with no explosive noise.

The observers turned around to look back to the west. Immediately, a *second* fireball appeared in the west, following the path of the first. It flew slightly lower, but at the same slow light-aircraft speed (i.e., about 100 mph) and, similarly, at constant altitude. Again it flew directly over the barbecue observers and was identical in all respects to the first fireball. Likewise, it moved at very high velocity to the east and disappeared in a massive blue-white flash of light-energy.

This was followed by a *third* fireball that was exactly the same size and travelled exactly the same low-level altitude (nearly in the treetops), exactly the same slow flight-speed, exactly the same course, and again disappeared at high speed to the east in exactly the same kind of light flash.

The time between the appearance of each separate fireball "pulse" was almost identical. Observers reported that after the first one had disappeared to the east, they swung around to look west, only to find that another fireball had arrived; and after that second one disappeared, they turned again to the west to see that a third fireball had arrived straight away—just like clockwork!

There remains a difference of opinion between observers as to exactly how many fireballs were seen in sequence that night. All observers agree that two fireballs were seen, but several claim that *three* were actually seen, but that strange time-space-mind distortion effects were in operation (emanating from the fireballs) such that confusion reigned immediately, during and after the sightings, leading to disagreement and argument over the exact number of discrete fireball events.

This entire sequence of events (or parts thereof) was seen by many of the inhabitants of Tom Price, i.e., possibly well over 2,000 people. Many eyewitnesses attempted to take photographs, but when they got their developed film rolls back from Perth they discovered their photos showed good family snaps and only white blanks where the fireballs had been! The films were developed by friends and were not tampered with, suggesting that X-ray or similar EM radiation from the fireball may have fogged the film.

One videocamera tape recording was made, but later accidental over-recording meant that only two minutes of this incident remained—taped as a pulsing light or fireball, as seen from well south of the fireball track. This videotape has since been appropriated by a UFO researcher in New South Wales and has never since seen the light of day.

All residents were shocked by what they had observed, eventually believing that someone deliberately wanted them to see these fireballs as some sort of test over an isolated outback town. They confirm that the object appeared to have no solid mass when seen close up, but from a distance many thought they were seeing an aircraft on fire—but the second and third fireballs disabused them of this idea. No one could align their sighting with anything within

their experiential memory. Some thought that "it was like the end of the world"—that same expression yet again!

The two policemen were taken the next day to a point halfway to the Paraburdoo townsite (residents there also saw the fireballs to their north that night), located some 50 km south of Tom Price. The policemen were briefed by "officials" on what had occurred and thereafter refused to discuss the evening's events with their friends in Tom Price.

Being a small town with few inhabitants, and pretty lonely if the other residents cold-shoulder you, one policeman later admitted that he would like to say what it was all about but had been ordered to keep his mouth shut and it was more than his job and life were worth to say more.

The residents of Tom Price discussed these events for days, but attempts to go public on Perth TV were met with ridicule and loony epithets.

They noticed that the fireballs had flown from the direction of the Exmouth Peninsula "US radio communications base" and knew that, in spite of recent newspaper publicity claiming that "this base has been deserted by the USA and handed over to the Australian government", there were still many Americans to be seen in the town of Exmouth who continued to live and work at the base (as is the case even now, in early 1997). Many suspect that there is a secret underground part to this base which contains peculiar, large aerial systems at ground level.

It was later discovered that the Dampier power station, further north-east, went off line at the time of the Tom Price fireballs due to a huge over-voltage pulse on the transmission lines.

Residents of this district have commonly seen or even been followed by bright white lights whilst traversing roads at night near the coast and adjacent to the Exmouth base area. They report that these lights move at low or high speed, at low or high altitude and commonly alter their courses.

Very bright white glows have been observed at night emanating from uninhabited bushland just to the east of Tom Price. Fireballs have been reported on several occasions in the period 1973 to 1994 as flying from Exmouth towards the east and the Great Sandy Desert.

SECRET WEAPONS TESTING AND OTHER SCENARIOS

In this Tom Price instance we appear to have a possible direct link to US bases. Thus it is feasible that high-powered EM weapons systems are being tested by the USA—or some other foreign government—on Australian soil, or that off-planet alien UFO interest in the Exmouth US base is being demonstrated in these sightings.

Regular passage of three such slow-speed fireballs, ultimately increasing rapidly to very high speed, occurring at exactly equally-timed intervals, along the same very-low-altitude trajectory and course, cannot involve any normal meteor or bolide-train event. These fireball events do not appear to represent any known natural phenomenon, and certainly appear to fit the alien UFO, secret military spaceplane-testing or EM weapons-testing scenarios.

Eyewitness information about the interior of the Exmouth Peninsula "US VLF submarine communication base" proves to be extremely interesting. The main transmitter (Tx) site consists of one very high central aerial called "Tower Zero" positioned upon a low hilltop and surrounded by 11 equispaced smaller towers (each

The policemen were briefed by "officials" on what had occurred and thereafter refused to discuss the evening's events with their friends in Tom Price.

about 1,000 feet high). Each tower is connected by aerial wire forming a series of three concentric circular loops (in excess of 2.5 km diameter). Tower Zero is encased in wood/ asbestos sheeting to form a very high, enclosed oblong box, and has a two-man elevator running up the inside of the tower. The top inner aerial shape is surrounded by a larger enclosed box.

The aerial array utilises enormous quantities of copper tube and wire "ground counterpoise" arrays buried in the ground under the entire complex.

Access into the hillside tunnel opening takes one into a large (at least three-storey) underground section at the base of Tower Zero. Here is something like the innards of a giant "transistor radio" with a huge heavy-duty copper-wire coil some 50 feet high and 15 feet in diameter—all supported on hardwood (Jarrah) frames fixed with wooden (Jarrah) nuts and bolts! Sections are lined with stainless-steel sheeting. There may be further and deeper sections under the copper coil which were not seen by this eyewitness.

There is a large power station at the site, possibly running on gas from boreholes into a large natural-gas reservoir nearby.

Although officially recently handed over by the US Navy to Australian Navy control, the base still has many US "consultants" who live in the nearby town of Exmouth. The Jarrah fittings and copper coil in Tower Zero were installed in 1968, after the main building contractor teams had left the facility.

Supposedly this Exmouth Tx site is transmitting VLF or ELF radio messages to submarines. However, this eyewitness description of the underground wooden frame and giant coil is a dead giveaway. It perfectly describes major elements of Tesla's Wardenclyffe, Long Island, Magnifying Energy Transmitter—and his earlier Colorado

Springs research versions. The wooden construction is required to handle very high voltages and very high frequencies (possibly as high as microwave-band frequencies) by containing the induced coil electrostatic wave from discharge. It is *not* needed to handle very low frequencies (VLF) or extremely low frequencies (ELF).

Tesla claimed in 1908 that he could hit any antipodean planetary city with an enormous EM energy pulse, delivered in microseconds, that would "create an explosion equivalent to more than the power of the extant world navies' combined 'Dreadnought' battleship broadsides" (i.e., a huge force similar to that of a nuclear explosion) from just such a device.

Therefore, it would appear that the Exmouth US Tx site contains "Tesla" or "scalar" EM weapons systems and has been active since about 1969, i.e., in time to conduct the 1970 and earlier tests for which we see evidence, due east of there in the Great Sandy Desert, as many grid rows of 10-km-spaced earthquakes, looking like a chessboard—each of 3 to 5 Richter power.

EARTHQUAKES TO ORDER

In 1965, this section of the Great Sandy Desert area was (uniquely for Australia) covered by high-altitude U2 aerial photography, paid for by the US Government. Why?

In 1966, the French oil company Aquitaine Oil (now called ELF Aquitaine) took out a large oil exploration permit in this most isolated and difficult-to-access area of Australia. Canberra even paid half the exploration costs to help explore the hinterland. No other company known to me ever got this type of deal—especially to

explore an area of poor conceptual potential in a poor geological environment when many easier-access and far better geological environments with excellent conceptual potential existed elsewhere in Australia and were open for acquisition and exploration.

Aquitaine commenced exploration in 1967 and carried out aeromagnetic, ground gravity, seismic traverse, and ground VLF/ELF EM studies. (These EM techniques were quite rare and odd exploration techniques to be used in oil exploration.)

In 1968-69, Australian Army MPs with 4WD Jeeps were airlifted into the Great Sandy Desert to round up a couple of hundred nomadic Aboriginal tribespeople and ship them out to Broome. This region was declared "off limits to the public", and all access tracks into the desert were guarded by Military Police. The published reason for this was the danger from a series of test launches from Woomera in South Australia, over the Great Sandy Desert and Broome, of the British *Blue Streak* missiles, and of the European four-stage space rocket satellite-launching system. (They even got this one into orbit eventually in early 1970 and 1971.) Thereafter, the British missile program and the European space effort were rather mysteriously and suddenly closed down.

In 1970 Aquitaine did no field work. In late March 1970, a series of concentrated 3.0 to 5.0 Richter-scale earthquakes com-

menced in the eastern Great Sandy Desert. (Note: no earthquakes have ever been known there since seismometers were installed in WA in 1900; also, there is *no* Aboriginal racial memory of quakes in this region.)

These quakes stopped in early October 1970, only to recommence the following year. Isolated quakes have continued every year since 1970. The late March to early October period is the only viable field period in this region—due to the extreme temperatures of 50+ degrees Centigrade in the months of

It was later discovered that the Dampier power station, further northeast, went off line at the time of the Tom Price fireballs due to a huge overvoltage pulse on the transmission lines.

November to February.

In 1972-73, Aquitaine drilled two stratigraphic holes (both dry) and walked away from the permit. Their annual exploration work reports (1966-1973) should be on 'open file' at the WA Mines Department library in Perth; however, they are listed as confidential. No copies exist in Perth as they are held under lock and key in Canberra at the AGSO (ex-BMR) offices. This situation is unique in all my WA exploration experience.

In 1973 the BMR (Bureau of Mineral Resources) published a report about the strange explosion of new earthquakes in the eastern Great Sandy Desert. This report contained incorrect quake epicentre maps—apparently biased *not* to show the strange, regular positioning of these quakes along a 10-square-kilometre-spaced grid over an 80 km by 70 km area, with a central two-kilometre-spaced series of quakes along two lines forming an apparently central 'aiming point' cross.

The 1996 AGSO Mundaring Observatory epicentre data demonstrates this regular quake epicentre pattern very well. The accuracy of epicentre determination is thought to be +/-10 km. Other Australian areas of dense quake distribution show chaotic elliptical area spreads clustered statistically around central points—not regular grid lines of quakes marching through the desert. These quakes are not due to seismic explosives—unless they used several kilotonnes at each shot hole!

The Great Sandy Desert earthquakes are distributed almost

Continued on page 93

The Treasure Trove of the Knights Templars

The Inquisition failed to eliminate the mysterious Knights Templars. The Order went 'underground' for centuries but has been reborn in recent decades.

Will the secret Templar treasures, allegedly found below a castle in France, ever be revealed?

by André Douzet ©1997

Edited & expanded by
Filip Coppens
Frontier 2000
PO Box 372
8250 AJ Dronten, The Netherlands
Fax: +31 321 318892
E-mail: fsfilco@glo.be

THE MYSTERY IN PERSPECTIVE

The date was 18 March 1314. On a small island in the River Seine in Paris, three persons were burnt to death: Jacques de Molay, the last Grand Master of the Order of the Knights Templars, then the world's most famous and wealthiest organisation; Geoffroi de Charney, the Order's Preceptor of Normandy; and a third person, whose identity varies from author to author. It was the official end of 200 years of Western European history that was dominated by the Crusades to reclaim the Holy Land, the introduction of paper money, and the meteoric rise of a group of celibate warrior-monks.

Hundreds of books detail the story of who the Templars were, how they gained both wealth and influence, and the circumstances that caused their downfall. In the end, though, certain things are left unexplained or unaddressed. In recent years, the mystery of the Templars has been a source of wealth for many international bestseller-writers, but some of their statements are outright lies, contradictions or misunderstandings of events. In any case, there are many enigmas concerning the Templars that probably won't ever be solved. But upon the horrible and burnt remains of these three people, a mystery began that has influenced history and society ever since.

There are several unanswered questions at the centre of the Templar enigma. Was there an inner circle, with a specific teaching comprising esoteric ideas or a secret doctrine? What happened to the fabled Templar treasure for which so many people were tortured and killed? Did this treasure contain documents or other material that identifies the possible secret doctrine of an inner group? Can that treasure be located and retrieved? Finally, the most intriguing question of all. Did the Order of the Knights Templars, and all that it stood for, disappear completely or did it continue as a secret 'underground' movement?

The answers to these questions may well lie within a small castle in the Rhône Valley. Moreover, the genesis of the current interest in the Templars can be found there as well.

It seems evident that the last of the Templars had foreknowledge of their impending arrests. They also knew that putting up a fight would be futile. They realised their time had come, and probably started preparing for a secret survival of the Order, very much like the Germans tried to do at the end of the Second World War.

One document that details the survival of the Knights Templars is the "Document Rubant", named after its author. Based on source material dated 11 April 1308, the origins of this document have never been contested, though few, if any, historians and writers on the subject credit it or know of its existence. This document is dated from the 18th century, before the enigma of the Templars became fashionable, and it seems very unlikely that it is a fake. If it were, it would definitely be the most unsuccessful fake ever.

The document states that all the documents "taken by the researchers of Philip Le Bel were real fakes, produced a long time before, in case an uncontrollable or unforeseen attack on the Order would occur; a kind of fail-safe mechanism in place since the beginning of the Order." The document states that the goal of the Templar researches in the Holy Land was to access a "knowing" of a very high level. This knowledge, for Rubant, is the reason for the Order's existence. It was a quest that dictated the inner circle of the Order and largely influenced the Order's history; a carefully prepared initiation to understand a total and all-enveloping knowledge that is guarded by an Egyptian goddess who caresses that information behind her veil. Rubant states that "the Templars were definitely much more advanced than us, because of a secret knowledge they had gained in books.

They discovered a complete and absolute knowledge...", or wisdom.

Rubant echoes the words of Raoul de Presle de Laon, lawyer and legal expert for the King's Court. "When I lived in Laon, one of my friends, who was Rector of the Temple of Laon, Brother Gervais de Beauvais told me, I do not know how many times, in front of several witnesses, that within the Order there existed a rule that was so extraordinary, and upon which such a strict secret nature was placed, that people would prefer to have their heads chopped off instead of divulging it. At the General Chapter there existed a secret practice that, even if the king of France was a witness, the members of the chapter would kill him without any regard as to the quality of the man. He vowed to me that he possessed a rule of the Order that he showed voluntarily, but that he also possessed a more secret one which he wouldn't show to any person not initiated."

Was this the secret which Grand Master Jacques de Molay held while being tortured by the Inquisition? On 26 November 1308 he told the Inquisition: "I would like to tell you certain things, if only you weren't the people you are, and if you were authorised to hear it." On 28 November he reiterated his desire to confide something in the Pope. It seems he was willing to lift the veil on something that was too complex for the mere mortal, and which apparently involved some form of unification between Christianity and the secret doctrine of the Templars.

Alas, the Pope would not hear de Molay, so it seems that de Molay must have decided that the Orders' treasure had to survive on its own—and chose the little French village of Arginy as the place to bear the treasure of the Templars. On the night of 12 October 1307—the night before the Templars' arrest in France—two knights stayed at Arginy, only to leave the place in the middle of the night and be arrested at Macon the following morning.

In a story that is both strange and recurring, it is said that on the eve of being burned, Jacques de Molay asked for his nephew, a certain Count de Beaujeu, after having bought the silence of his keepers and the soldiers with gold. The meeting took place in the Grand Master's cell and is said to have lasted some considerable time. Jacques de Molay gave his nephew certain instructions: he was to go to the Temple in Paris, where the former Grand Masters of the Order were buried, retrieve a crystal relic and bring it back to de Molay as soon as possible. Then followed a second meeting that had grave implications for the survival of the Order. De Molay explained to de Beaujeu that the relic he had just recovered from the Temple was John the Baptist's sacred index finger with which he had identified Jesus Christ. The treasure had been given to the Order by the former King of Jerusalem, Baudoin.

Afterwards, de Molay entrusted the future survival of the Order upon de Beaujeu, giving his nephew the necessary information to make sure he could bring his delicate mission to a fortunate end. He gave him the keys and the directions to a place known only to the Grand Master, close to the tomb of a former Grand Master. De Beaujeu would discover the secret of the Order's existence in a coffer.

After his encounter with Jacques de Molay, de Beaujeu had to gain entry into the Temple. He came up with the excuse that he wanted to conserve the mortal remains of his uncle, a former Grand Master of the Order, so, for a small fortune, he was allowed in. De Beaujeu and nine other survivors recovered the precious relics and placed them in a 'pretend' sarcophagus. Certain researchers think the team set course for Cyprus, where the headquarters of the Order could harbour the smugglers and their treasure. But tradition informs us that de Beaujeu rapidly moved towards the only place where the treasure would be safe: Arginy, a castle that belonged to him but was not Templar property.

...Brother Gervais de Beauvais told me, I do not know how many times, in front of several witnesses, that within the Order there existed a rule that was so extraordinary, and upon which such a strict secret nature was placed, that people would prefer to have their heads chopped off instead of divulging it.

THE SUBTERRANEAN SECRETS OF ARGINY CASTLE

Daniel Réju describes Arginy as "an isolated castle in the plains, between Saône and Beaujolais", north of Lyons. Its origins go back to the Celtic Druids who exploited a saltmine in the vicinity. Arginus, a veteran of Roman Emperor Julius Caesar and probably a man initiated into the ancient Greek mysteries, built a small fortress which he named after himself. A millennium later, the ruined castle was rebuilt, and passed into the ownership of the de Beaujeu family. In later centuries, it was bought by Vinols, a close friend of Jacques Coeur, one of the wealthiest merchants of France, if not the world. Apparently, Coeur did not want to buy the castle, as that might make people suspicious. Still, Coeur apparently had a major interest in the castle and tried to stay as close to it as possible.

But let us return to the de Beaujeu family. Arginy became the principal seat of the family in 1253. Some decades later, Guillaume de Beaujeu would become a famous Grand Master of the Knights Templars,

dying in the massacre of St Jean d'Acre, a military disaster in the Middle East that heralded the downfall of the Knights Templars. Guillaume de Beaujeu's remains were taken to the Temple in Paris, where they were placed amongst those of the other Grand Masters of the Order. In 1314, his remains, together with the secret treasure of the Order, were placed in a sarcophagus and taken to Arginy, which was owned by strong Templar defenders but not a Templar property as such, and therefore out of reach for Philip Le Bel and his brutal Inquisition.

Arginy castle is situated on top of the intersection of three underground rivers and thus is a phenomenal source of water. The castle is equipped with underground rooms—apparently so essential in storing any kind of treasure. Because of the mining industry that existed there in much earlier times, there are several natural caverns near or underneath the castle. Indeed, it is a veritable maze of underground tunnels, caverns and rooms which could effectively cloak any treasure. As the Templars were also well-versed in hydrology, it seems only logical to assume that they could have engineered a system which could quickly open and flood these underground caverns—which is exactly what happened at Arginy, where the underground rivers could supply them

with enormous quantities of water to fulfil their task.

Though the treasure was apparently safe, the reputation of the castle as holding the Templar treasure became public knowledge, at least in certain circles. In later centuries, the dukes of Camus and Moncepey bought the castle. One member of the Camus family put alchemical graffiti in one of the chambers and on the herald of the castle. He made sure he would be buried in a subterranean chamber, so he arranged for his tomb to be defended by traps that would release huge quantities of water to surprise any trespasser. Tradition tells us that the tomb is very near the fabled treasure left by Jacques de Molay through his nephew, Count de Beaujeu.

Others involved in the Templar treasure hunt report that several levels of subterranean galleries exist underneath the castle. It is known that later owners of the castle made use of some or many of these galleries.

THE TREASURE HUNT BEGINS

The first organised search of the treasure trove left by de Beaujeu was organised by one of his descendants, Anne de Beaujeu. She talked about "very old documents that testified about the presence of a major and historical depot". The men entering the underground network of tunnels were decimated by traps that had probably been put in place by Count de Beaujeu. Anne de Beaujeu eventually gave up and had the entrance to the underground network sealed off.

In 1914, the new owner of the castle, Duke Pierre de Rosemont, felt the time was ripe for a new enterprise. After breaking down the wall that Anne de Beaujeu had built, the Duke opened the entrance to the underground caverns. One of his workmen, however, had his legs crushed when he was hit by two stone balls that rolled out of a wall—another trap installed so many centuries earlier. De Rosemont decided to change his tactics and opted for safer methods. After some scouting of his own, de Rosemont discovered a hole that led downwards, so he decided to try to reach the treasure on his own.

One of the Duke's descendants claims to have excellent evidence concluding that Pierre de Rosemont was able to gain access to the tomb of Camus—said to be very close to the secret treasure of the Knights Templars. Apparently, though, having almost reached his goal, the Duke was struck by violent blows and cries emanating from below, balls of mauve fire encircling the room, and strange odours and visions. When the water began to rise

mysteriously, he decided to retreat as quickly as he could. Upon reaching the surface, he decided never to return, so he made sure that no one would ever discover the hole through which he had reached the underground network.

The oldest part of the castle is a tower—the "Tower of the Eight Beauties". Constructed in red bricks, its walls are more than one metre thick. It appears circular from the outside, but inside, on the first floor, the tower becomes octagonal. At the top are eight openings that appear to have no functional use. It is also known as the "Tower of Alchemy", for the walls were once covered with alchemical symbols. Though these symbols are almost invisible today, but we have photographic records of them in our possession.

It was towards this tower that two of the greatest alchemists of our age set course: Eugène Canselier and Armand Barbault, the author of *Gold of a Thousand Mornings*. Their visit to the castle was not a tourist outing; instead, Barbault and his wife stayed there for several weeks, in the company of the now infamous Jacques Breyer.

In 1950, a mysterious English colonel came to Arginy and asked whether the owner, Gilbert Marie Jacques de Chambrun d'Uxeloup de Rosemont, was willing to sell the estate for no less than one hundred million French francs. De Rosemont flatly refused. Two years later, he and Jacques Breyer decided to have another go at discovering the treasure of Arginy.

THE BIRTH OF NEO-TEMPLARISM

The new team decided to dig underneath the Tower of the Eight Beauties. In their search they hit upon the underground

stream that was responsible for the sudden flooding that had plagued previous seekers. Jacques Breyer believed that the Templar treasures at Arginy consisted of several different forms, each requiring a certain kind of focus on his part if he was going to find them. He believed that there was a material treasure, taken from the Treasury of the Temple in Paris and therefore possibly involving large quantities of gold; a spiritual treasure, detailing the rituals and doctrines of the Order; and an esoteric treasure—a treasure of Wisdom that contained information on magic and Hermetic rituals. Breyer also believed that the castle might have been specifically converted into an "alchemical stronghold" so that certain alchemical experiments could take place there. In any case, it does seem that alchemical thought was applied in the Tower's construction.



The "Tower of the Eight Beauties" at Arginy castle

The birthdate of neo-Templarism is currently accepted as 12 June 1952; the birthplace: Arginy. The event is often referred to as the "the Resurgence of Arginy". Indeed, Arginy became the focal point of the Rosicrucians, Freemasons and other strange orders as well as numerous "Templar Orders". Important figures made visits to the castle. Amongst the visitors was Constantin Melnik, head of the French Secret Service and confidant of the French Minister of the Interior, Michel Debré, who visited the castle in 1959. Guarded by members of the Secret Service who cordoned off the entire castle, Melnik reportedly participated in night-time ceremonies held within the castle walls.

It was on 12 June 1952 that the first such alchemical ritual was held, conducted by Breyer, Barbault and his psychic wife and other people, some of whom were merely attendants. Breyer, who believed he was the reincarnation of Jacques de Molay, tried to reach the ghost of Guillaume de Beaujeu, whose remains had been placed close to the treasure underneath the treasure. Apparently Breyer was successful in this attempt, as de Beaujeu had asked for a certain ritual to be performed so that his spirit could be brought back to life. The ritual supposedly involved the sexual union between man and wife at Arginy, whereupon the resulting child would be the reincarnation of the former Grand Master.

Breyer stayed on at Arginy castle from 1952 until 1959. He stated that it was "a haunted place, but in the most lofty sense of the word: it is a place of high initiation." For seven long years, Breyer did all kinds of occult works and magical rituals, hoping to contact the souls of eleven Templars whose spirits had been charged with guarding the treasure that lay in Arginy's subterranean chambers. Perhaps the entire history of Breyer's searches seems foolish, but it is known that during those seven years he did discover an underground chamber and locate many entrances to the underground kingdom of Arginy. He reportedly found several small objects that were lying in numerous small holes. Some of these objects are allegedly kept in a private collection.

It seems that Breyer's supposed contact with the spirits of these

deceased Templars was rewarding for him, and it is certain that such contacts formed the basis for Breyer's research. Some of his contacts went extremely far on occasion, for certain rituals—today known as the "Rituals of Arginy"—apparently involved small children—a boy and a girl of about eight years old. Breyer left Arginy, saying contact with the entities was now established and occurring on a regular basis, not haphazardly as before.

During his time at the castle, Breyer prepared several books, but these are difficult to access at present. His most famous book is *Arcanes Solaires*, "dedicated to the Ancient 'Arch Masters', eleven in all, who came to help me during my seven-year stay at the castle of S." In referring to Arginy, Breyer always denoted it with the letter "S", or, even more commonly, with the symbol "\$". Breyer indicated that *Arcanes Solaires* is the résumé of the secret inheritance of the last Grand Master of the Temple, Jacques de Molay. He claimed to have told this story to the walls of the castle, and, like certain inhabitants before him, to have placed alchemical graffiti on the castle walls.

Breyer then founded a neo-Templar order, the Sovereign Order of the Solar Temple. Although this Order cannot be confused with the Order of the Solar Temple—responsible for the collective suicide of 53 people in Canada and Switzerland in 1994 and of 16 people in France in 1995—it is understood that Jacques Breyer was the great inspiration behind the foundation of the Order of the Solar Temple and also knew its leaders.

The Sovereign Order of the Solar Temple, however, was supposed to be the new Order of the Knights Templars. The eleven entities with whom Breyer conversed had requested that Breyer raise the spirit of former Grand Master Guillaume de Beaujeu in order that he could guard the development of the "resurgence" of his Order. As the story goes, everything had been put in place so that the ritual could be conducted, but apparently something was not quite right at the last moment. Something happened that no one had prepared for, and the experiment turned into a nightmare. Through personal research and interviews with the local villagers who lived on and around the estate, we learned that strange noises,

followed by horrible cries coming from the Tower of the Eight Beauties were heard ever more frequently. Luminous events sparked off by these rituals preceded the fierce escape of the participants.

Even though the resurrection of Guillaume de Beaujeu was probably unsuccessful, it seems quite certain that some or several of the eleven guardians were liberated but chose to remain voluntary captives of Arginy castle.

The Sovereign Order of the Solar Temple (OSTS) was the exoteric result of the initiates' constant participation in events that transpired at the castle. The Order elected its first Grand Master in 1966, and announced its existence the following year in the form of an association. The Order was officially recognised by Prince Rainier III of Monaco—the location of the Order's official headquarters. Book publishing is one of its functions.

The OSTS was the inspiration for most neo-Templar orders that have subsequently seen the light of day, including the already mentioned Order of the Solar Temple, but also the Renovated Order of the Temple—



The house where Jacques Breyer stayed at Arginy

the ORT. Researchers investigating these orders claim to have found evidence that they are closely connected to extreme right-wing circles, particularly the Italian *Propaganda Due*, P2. Even if this is correct, it should be noted that from its inception the OSTS seems to have been of a totally different calibre. Indeed, it is more likely that any such links were merely the result of certain people's interest in Breyer's works and his organisation.

THE SECRETS STAY HIDDEN

Though numerous places claim to hold the treasure of the Templars (some as far as away as Canada), Arginy is arguably the only place where such important events have transpired. Though several people would wish that the castle, and what has transpired there, did not become public knowledge—if only because of the gruesome events that eventually led to the collective suicides of 1994 and 1995—it should be remembered that what took place at Arginy had one goal: to give mankind an important revelation. In former centuries, such information was held by the secret circle within the Knights Templars. This may explain why Breyer and other key people went to Arginy in the years following 1952 and participated in strange magical rituals: they believed Arginy held the key to something very important.

Unfortunately, whatever that revelation was, it has been suppressed. It does seem most likely, though, that the castle holds within its walls one of the most important secrets of the Knights Templars. When this secret will be revealed—or whether it will be revealed at all—is not known.

Since 1959, many people have attempted to fathom this enigmatic secret. Having lived around the castle of Arginy, I am aware that many curious, painful and sometimes dangerous things happen every time someone tries to grasp the terrible secret. Local folklore has it that only one person is designated and recognised by the deceased Templars to have access to them without risk to his or her life. The tradition thus reactivated, it is claimed that the Order shall rise from its ashes towards a higher and more certain glory.

Perhaps the French author Robert Charroux found the key when he deciphered this passage from Breyer's book: "Think hard: the great art is Knowledge."

About the Author & Editor:

André Douzet was an architect before turning his attention to full-time research into the mysteries of France, particularly the Templars. He is the researcher who brought forward the *maquette* possessed by Abbé Bérenger Saunière, the prime-mover behind the Rennes-le-Château mystery.

Filip Coppens is an author as well as Editor of *Frontier 2000*, the Netherlands-based magazine specialising in UFOs, ancient mysteries and the unexplained.

Note:

A 60-page booklet, written about Arginy and the survival of the Templars, is now available. It contains photographs and documents, including the "Document Rubant" which details the Order's survival. The booklet can be purchased for USD\$15.00 from the Netherlands contact address listed at the beginning of this article (foreign orders, add USD\$5.00 surface mail or USD\$10.00 airmail).

Charles G. Addison's classic text, *The History of the Knights Templars*, originally published in 1842, has recently been republished by Adventures Unlimited Press, with an extensive introduction by David Hatcher Childress. To obtain a copy in the US, telephone Adventures Unlimited on (815) 253 6390; elsewhere, contact your local NEXUS Office for details.



**COMET HALE-BOPP:
EX-VATICAN PRIEST LETTER #2**

[In our last issue we ran what is now referred to as "the Vatican Priest Letter". This was the letter sent on 11 December 1996 to Art Bell of the well-known US radio talkback show, purportedly by (you guessed it) a former Vatican priest, hinting at untold mystery surrounding the Comet Hale-Bopp.

The letter has sparked immense debate worldwide, and for the benefit of non-Internet-connected readers we now present the text of the second letter, dated 20 February 1997. If you want know of more such letters, you will have to connect to the net at home, work, school, uni, café, local library or a friend's place and visit Art Bell's web site at www.artbell.com. Ed.]

Mr Bell: To preface this letter, if you intend on reading it to your listeners, I will tell you that the gentleman who was previously forwarding my messages is unfortunately no longer with us. He was killed very violently while on a vacation in southern California. He was found by police in his hotel room, tied up, with gunshot wounds to his head and spine. His mother was sent pictures of him just before he was shot. These photos were sent with a warning. I don't think I need to elaborate any further on that. I mourn his

loss deeply, and I pray that yet another death will not be in vain. It adds a new seriousness to the passage I told you to read regarding hope.

I apologize for having been gone for so long. I was unavoidably detoured for a number of weeks. I am fine. I have been recovering from a gunshot wound that I received around Christmas time. The bullet, near as I can tell, was not meant to kill me but to cripple me. The bullet missed my spinal chord by approximately 4 centimeters. I am still having difficulties, but I am getting better every day.

I want you and all of your listeners to know that I have made arrangements for you to receive some information. I have unlocked the disc I was working on and I am, to say the least, very frightened.

Without going into too much detail, the disc contained a good deal of information concerning what your remote-viewer friend had to say. The Vatican, too, has a staff of astral operatives, and operatives trained in remote viewing. They have, for some time now, known of the virus that he spoke of, and according to them it is very real.

I will also be sending you detailed information of two projects that the Vatican is involved with currently.

1) They have worked to successfully stop a program called Space Guard. This program was headed by a man in Australia

until it was shut down. Its main purpose was to track all known comets, and determine any possible "Earth Colliders". The program's funding was cut altogether by NASA, which was only to the amount of 1 million dollars anyway, and by the Vatican. And I will go into detail in the information you will be receiving.

2) I have learned of a vast number of training facilities across the globe, but mostly in the US, that are training what I can only refer to as the Vatican Guard. These soldiers are being trained for what the Vatican feels is an impending holy war. These soldiers are being trained in biologics, nuclear fallout conditions, and the use of Astral Combat.

This is far more reaching than I had ever imagined, Mr Bell. I do hope that you mull over the information you will be getting very seriously, as it is the truth. I apologize for the anonymity with regards to this e-mail, but under the circumstances I do not wish to endanger anyone else. I will from now on be sending you all information personally. Any other address, other than the one you just received, is not from me and should be treated as such. I will be in contact soon. God be with us all.

(Source: E-mailed to Art Bell at artbell@aol.com on 20 February 1997. Also available from the Art Bell web page, <http://www.artbell.com>)

THE TWILIGHT ZONE

ROSWELL ALIENS PHONE BACK WITH WARNING?

Recent disclosures about animal cloning in Scotland and the US have raised a storm of polarised reactions round the world. Some, obsessed with technological progress whatever the cost, are excited about the prospects for human genetic 'therapy'. Others, full of foreboding about these developments, say we know too little about the consequences to go down such a route and should rethink our ethical principles before it is too late.

In our next issue we shall feature a new book which illuminates this controversy. The core of *The Roswell Message* comes from ET crew members who mentally survived the crash. This channelled material is part of a very thorough update and analysis of the whole Roswell scenario.

What the ETs say is that they had a common ancestry with us, and that they want to warn us not to make the same mistake that they did, for they embarked on a program of genetic engineering which erased individual differences. As a result they are now in an evolutionary dead-end.

Their message is both a healing and shocking warning against genetically-programmed apocalypse and a cry for help from their threatened civilisation.

The Roswell Message, by René Coudris, will be published by Gateway Books, UK, on 4th July—the 50th anniversary of the spacecraft crash—and will be reviewed in the next issue of NEXUS.

MARINE LIGHTWHEELS: CROP CIRCLES OF THE SEA?

by Kris Sherwood ©1997

A few months ago, to my utter amazement, I became aware of a little-known and mysterious phenomenon known as "marine lightwheels". Astonishment grew as I researched the facts. I now have little doubt that at least some of the physics involved are similar to those that create crop circles.

Reports of "marine lightwheels" or "submarine lightwheels" have been recorded by mariners for more than a hundred years, and one source states that they are also mentioned in ancient Indian literature.

They are almost exclusively seen in the waters of the Indian Ocean, the Persian Gulf and the South China Sea, but have also been reported in the Gulf of Mexico and off Western Australia. They are all in close proximity to the latitude of 19.5 degrees—a fact I find very interesting.

There are hundreds of reports on record describing these gigantic, rotating, rimless wheels of light, seen on or just under the surface of the water, though there are also a few reports of the phenomenon appearing aerially just above the water's surface. While the source of the light itself has been attributed to the bioluminescent marine organisms, or *Noctiluca miliaris* (plankton), present in profusion in these waters, what is it that is stimulating them to produce the vast and complex geometrical displays that have been reported?

Most witnesses describe first seeing a

distant pulsing or oscillating light approach from the horizon. As it nears, radiating spokes of light moving rotationally on the surface of the water become visible and are seen to be rapidly revolving around a central hub that is described as being not brighter than the rays.

Nearing the observer's ship, the bands of light have been seen to curve concavely into the direction of their rotation, each band passing the ship at the rate of roughly one-second intervals and at speeds of 60 to 200 miles per hour.

As the 'lightwheels' approach and cross the area occupied by the boat, there is no apparent effect from the boat on the progress of the light display; though on occasion it has been noted that the lightwheels seemed to follow with the boat, or, in the case of multiple wheels, to converge with the vessel's course for a time.

Light from the 'wheel' has clearly been observed reflecting up onto the ship; not coming from overhead or being 'beamed down'. Rather, it seems to come from below the water's surface.

The lightwheels have been estimated to be made up of roughly 16 radial spokes of light. The width of the light-spokes is usually equal to the spaces between them, and has been reported to vary from 20 to 70 feet depending on the size of wheel. This width remains constant throughout their length, not widening at the terminus the way a beam of light would.

The spokes or rays have been described as forming "sinusoidal curves" or "flattened Ss", revolving around their hubs and curved like a "Catherine-wheel".

The diameter of the wheels has been estimated at 500 to 600 yards, though there are widely varying sizes reported in the individual accounts. In some cases the diameter has been put at a half-mile or more.

In the case of multiple-wheel events (or, on occasion, concentric, radiating-ring displays), the first in the formation is the largest and the following ones tend to diminish in size. Occasionally wheels will overlap, simultaneously turning in opposite directions around separate hubs. One sighting describes two sets of concentric, radiating, circular light-rings that were followed by an elliptical set of rings which radiated at a much faster rate than the circular ones.

This particular sighting, from the Gulf of Oman in October 1960, also included the description of "three separate vortices"



spaced out in a straight line on the water's surface, about 600 feet apart, from which the concentric rings of light emanated at the rate of approximately one per second.

Sometimes these lightwheel displays have been seen to be preceded by straight horizontal bands of light approaching side-on from a distance in "waves" before the onset of the rotating rimless lightwheels. These wheel displays then finish with a similar set of horizontal bars.

Groups of rotating circular patches of phosphorescence have also been seen in the same area. Another report from the Gulf of Oman, in 1951, attributed ship's radar, or some type of "sound excitation" of the *Noctiluca* by indigenous marine mammal communication, as the cause of a mass display of brilliant, whirling phosphorescent crescents that were seen spinning—clockwise to starboard and anti-clockwise to port—inward toward the ship's bow and extending outward close to two miles.

The duration of these "lightshows" has been said to last from 15 to 30 minutes. No occurrences have been reported in open oceans; instead, they tend to happen in landside straights. (I am not a mariner, but that description sounds like it refers to something akin to the tendency of crop circles to form on leeward slopes.)

Seventy per cent of the lightwheel sightings have been during March through June, and 60 per cent of these in April, May and June. Additionally, at times the sea sur-

face has been seen to "boil" during the event. A "swishing" sound has been heard that's been likened to that heard during "low-level aurora displays", and compasses have "gone haywire" in the centres of these wheels! I have even come across ironic (and eerily familiar) comments about how scientists have generally ignored the phenomenon, writing it off to "wild sailors' tales".

The parallels to the crop circle phenomenon are obvious, but how does it fit together? I suspect a critical combination of elements has to come together in order to trigger a crop circle event. Part of the physics involved may work much the same way as it does in lightning strikes and involve a similar ground-based electromagnetic component. Among other things that may be involved are ley-line energies, Earth-energy grid points (Bruce Cathie's work), the Van Allen magnetic belt, and, in the case of lightwheels, the energy concentration at latitude 19.5° north and south (Hoagland's work in tetrahedral geometry).

The lightwheels, by a combination of synchronous ingredients, may be an image of one or more of these energies as captured and revealed by the agitated phosphorescence of the local marine life. Why the Indian Ocean seems to be the centre of this phenomenon, when *Noctiluca* is found in abundance in many other areas, is a mystery. Could this area near the Indian Ocean be a power point of converging energies, similar to southern England?

While I'm convinced that in the case of crop circles there is a powerful intelligence behind the emergent designs, I think naturally-occurring energies are being applied in their formation. Lightwheels may be a 'shadow on the wall' of one of them.

Writing this piece, I kept seeing an image of lightwheels roaming the ocean's surface, like the energy in a glass plasma-ball (the kind you can buy in some specialty shops) that radiates from the centre randomly until you touch it and it 'magnetises' to your hand. But what 'hand' is involved here?

"The versatility of the unknown geometer creating the marine displays seems unbounded." (From *The Handbook of Unusual Natural Phenomena*)

References

- Corliss, William R., *The Handbook of Unusual Natural Phenomena*, Crown Publishing, New York, 1986.
- Sanderson, Ivan T., *Invisible Residents*, World Publishing Co., 1970.
- *The Books of Charles Fort*, Henry Holt & Company, New York, 1941.

Note: The marine lightwheel illustration is by Ed Sherwood. The author and illustrator can be contacted as follows:

Millennium Research, PO Box 2084
 Santa Monica, CA 90406-2084, USA
 Telephone: +1 (310) 319 9329
 Also visit Crop Circle Connector web site: <http://www.marque.demon.co.uk/connector/connector.html>

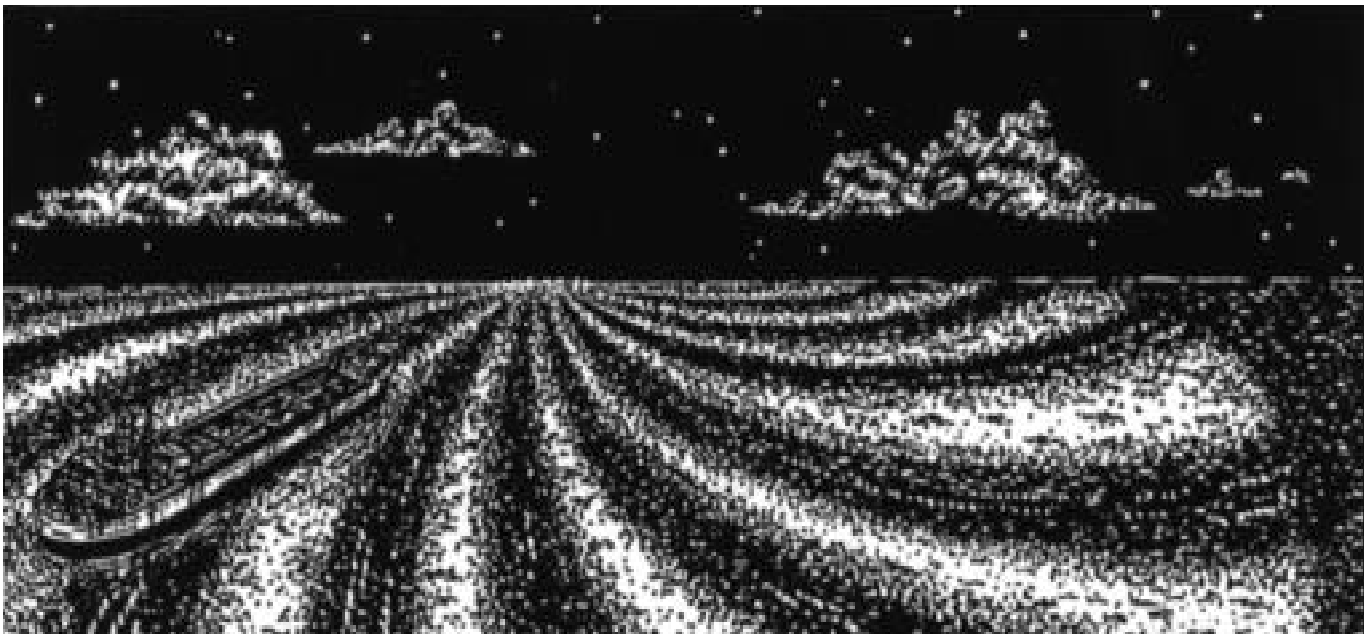

THE TWILIGHT ZONE

THE 'HOLE' TRUTH?

Radio audiences in the USA were puzzled recently by the mystery of "Mel's hole", an alleged bottomless pit, somewhere near Ellensburg, Washington.

When radio talk show personality Art Bell received a fax from a man purporting to have the world's deepest hole on his property, Bell took it to the airwaves.

Bell, who hosts the nationally syndicated "Coast to Coast" program that airs on 328 radio stations across North America, is no stranger to the bizarre. His program regularly features topics that delve into the fringe, whether it's alien abductions, asteroids or crop circles.

During Bell's Friday night show, a man identifying himself as "Mel Waters" recounted the story of a seemingly bottomless pit on his private property along Manastash Ridge, which runs south of Ellensburg. He claimed that he, like previous property owners, had been dumping trash into the nine-foot-wide hole for years.

"People have been throwing their trash in the well for decades: furniture, household trash, dead cows, building debris, you name it," Mel told Bell. "The hole never filled up, so I got curious—actually, obsessed—and began trying to measure the depth of the hole."

Using fishing line and a one-pound weight, Mel claimed to have fed 80,000 feet of line—or 15 miles' worth—into the hole and said he still didn't hit bottom. Because the fishing line only had the

strength to hold 20 pounds, he said he couldn't go any deeper for fear of snapping the line, since its cumulative weight was at 17 pounds.

On Monday, Mel returned to Art Bell's program with an update: the military had seized his property Saturday, moved heavy equipment onto it and surrounded it with cement barriers.

"There were armed soldiers," he said.

Mel then wondered if he'd be able to fulfill his wish of having his body tossed into the well after he died. He said he had decided that's how he wanted to go after hearing the legend of the dead hunting-dog that was dropped into the pit.

Listeners called in with ideas to help explain Mel's anomaly. But perhaps the greater mystery is: "Who's Mel?"

Soap Lake resident Richard Dawe, who heard the broadcast, tried to track down Mel and his property. And, as the Yakima *Herald-Republic* confirmed, there is no telephone listing for a Mel Waters, nor do Kittitas County records show any such person owning property along Manastash Ridge or elsewhere in the county. County emergency officials said they knew nothing about Mel's hole, except from what they'd learned from reporters' questions.

Even if Mel's hole does exist, it can't be as deep as he claims, according to Steve Reidel, a Richland geologist who teaches at Yakima Valley Community College. "Technologically, it's a feat beyond humans," he said. "No one has ever drilled a borehole that deep. Geologically, it

wouldn't stay open. The horizontal forces of the Earth are very strong and they would close it off."

Bell said that he, too, may never know the truth about Mel's hole, but such is the nature of talk radio.

(Source: Written by Wendy Harris, Yakima *Herald-Republic*, 26 February 1997)

TV SIGNAL IN TIME-SPACE WARP

Have you ever wondered what becomes of old radio and TV programs that are sent out into space 24 hours a day? Do they just fade out and vanish, or do they keep travelling through space forever, perhaps to be picked up by creatures on other planets?

Possibly some of the weird sounds that we hear are really programs (or commercials) from other planets. It's true that scientific listening posts have put on tape some mighty odd sounds from space which might be from some sort of intelligence somewhere. Some make no sense at all (perhaps those are the commercials).

In the early days of television, some sets retained a picture long after a program was over. Even today, words from a commercial linger after the advertisement has left the screen, and occasionally another channel's picture will appear for a few seconds. But what about pictures that mysteriously appear long after the program has finished?

In September 1953, many television screens in England suddenly carried the identification card and call letters of TV station KLEE in Houston, Texas, thousands of miles across the Atlantic. The image stayed on the screen long enough for several viewers to take pictures of the remarkable occurrence. TV usually fades out after about 150 miles unless helped along with electronic devices and relay stations. In 1953 this was not possible. Even today, transatlantic programming is just beginning.

What really startled the TV world was the fact that when the British broadcasting engineers contacted KLEE in Houston to tell them of the unusual event, they learned that the station had been off the air for three years. Since that time, no KLEE identification card had been shown.

Where had the picture been for three years? Why did it only appear in England, and how did it get back from wherever it had been?

(Source: Dennis Ballard, Anchorage, Alaska, USA, phone +1 (907) 277 8957)

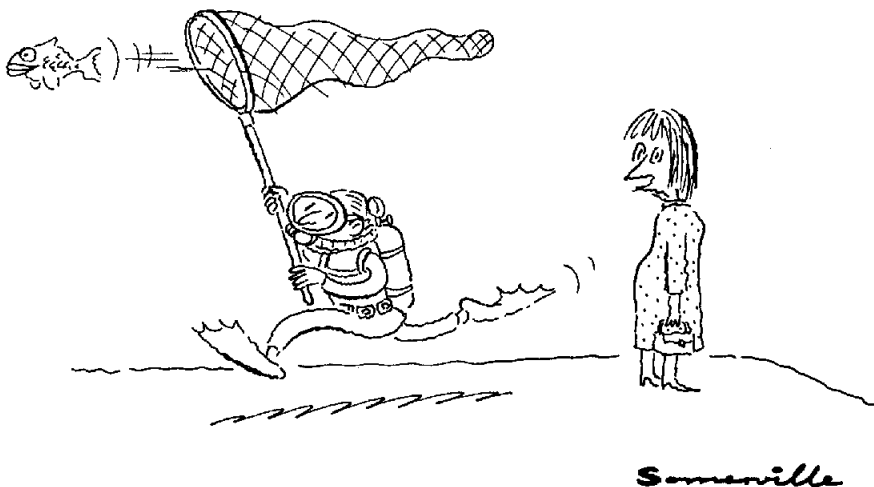

Strange Tales about Sea Serpents

Many reliable eyewitnesses over the centuries have reported bizarre encounters with monstrous 'sea serpents'.

Are these reports really descriptions of the plesiosaur and ichthyosaur, living underwater relics of the age of dinosaurs?

by C. D. Pollard ©1996

1 Highfields Grange

Cheslyn Hay

Walsall, WS6 7PF, UK

Telephone/Fax: +44 011922 414703

There is a general disposition to regard the sea serpent as an everlasting joke. 'He' only turns up, say the jokers, when the silly season arrives with its prize gooseberries and showers of frogs. Nevertheless, there is reason to believe that the sea serpent is a living fact, and there is evidence that great living creatures yet unclassified by science inhabit the sea.

The Norwegian fishermen of the past regarded the existence of the sea serpent as something beyond all dispute, and a Norwegian travel book published in the 16th century reports its appearance in the year 1522. Olaus Magnus described the sea serpent as being 200 feet long and 20 feet in circumference, having fiery eyes and a short mane.

Hans Egede, who later became a bishop, travelled to Greenland in the year 1734 as a missionary. In his account of the voyage, he described a sea monster which appeared near the ship on 6 July:

"Its head, when raised, was on a level with our main-top. Its snout was long and sharp, and it blew water almost like a whale; it had large broad paws or paddles; its body was covered with scales; its skin was rough and uneven; in other respects it was a serpent; and when it dived, the end of its tail, which was raised in the air, seemed to be a full ship's length from its body."

Erik Pontoppidan, the Bishop of Bergen and a famous Norwegian naturalist, was sceptical of sea serpents but confessed his conversion in his book of 1755 after receiving reliable evidence. He stated that the creatures kept to the bottom of the sea except during spawning in July and August when they rose to the surface. He discriminated between the Greenland and Norwegian sea snakes—the former being scaly, and the latter being perfectly smooth with a mane about the neck, hanging like a bunch of seaweed. He estimated the serpents at about 600 feet in length. They had high, broad foreheads, though some had sharp snouts and others flat. The eyes were large and bluish, and the skin dark-brown or patchy.

The *Zoologist* for the year 1847 contained many accounts of the appearance of sea serpents in the Norwegian fjords, but one of the most famous and best authenticated appearances of a sea monster was recorded by HMS *Doedalus* in 1848. The official report by Captain M'Quhae to Admiral Sir W. H. Gage follows:

"Sir, In reply to your letter requiring information as to the truth of a statement, published in the *Times* newspaper, of a sea serpent of extraordinary dimensions having been seen from Her Majesty's Ship *Doedalus*, under my command, in her passage from the East Indies, I have the honour to acquaint you, for the information of my Lords Commissioners of the Admiralty, that at 5 o'clock p.m., on 6th August last, in latitude 24 degrees 44' S. and longitude 9 degrees 22' E., the weather dark and cloudy, wind fresh from the N.W., with a long ocean swell from the S.W., the ship on a port tack, heading N.E. by N., something very unusual was seen by Mr. Sartoris, midshipman, rapidly approaching the ship from before the beam. The circumstance was immediately reported by him to the officer of the watch, Lieutenant Edgar Drummond, with whom, and Mr. William Barrett, the master, I was at the time walking the quarter-deck. The ship's company were at supper.

"On our attention being called to the object, it was discovered to be an enormous serpent, with head and shoulders kept about four feet constantly above the surface of the sea; and, as nearly as we could approximate by comparing it with the length of what our main-topsail yard would show in the water, there was at the very least 60 feet of the animal à fleur d'eau, no portion of which was, in our perception, used in propelling it through the water, either by vertical or horizontal undulation. It passed rapidly, but so close under our lee quarter that, had it been a man of my acquaintance, I should have easily recognised his

features with the naked eye; and it did not, either in approaching the ship or after it had passed our wake, deviate in the slightest degree from its course to the S.W., which it held on at the pace of from 12 to 15 miles per hour, apparently on some determined purpose. The diameter of the serpent was about fifteen or sixteen inches behind the head, which was, without any doubt, that of a snake; and it was never, during the 20 minutes that it continued in sight of our glasses, once below the surface of the water; its colour, a dark brown with yellowish white about the throat. It had no fins, but something like the mane of a horse, or rather a bunch of seaweed, washed about its back. It was seen by the quartermaster, the boatswain's mate, and the man at the wheel in addition to myself and officers above mentioned."

This is unassailable evidence from the best source possible—the observation of several educated men used to the sea, and set down in a sober, official report. A letter was printed shortly afterwards in the *Globe* newspaper, giving an account of the appearance of a similar monster seen from the American brig *Daphne*, 20 degrees further south, soon after it was seen from the *Doedalus*.

Captain W. H. Nelson, of the American ship *Sacramento*, reported catching a glimpse of a strange sea-monster on 30 July 1877, on latitude 31°59'N, longitude 37°W. John Hart, the man at the wheel, had a better view than Captain Nelson, for he was the one who first caught sight of the creature and the Captain did not arrive upon deck until it had proceeded some distance. Some 40 feet of the creature was seen above the surface, and its girth appeared to be about that of a flour barrel. Indeed, it resembled an ichthyosaur.

An account from an officer of HMS *Plumber* ran as follows:

"On the morning of 31st December 1848, lat. 41 degrees 13' N., and long. 12 degrees 31' W., being nearly due west of Oporto, I saw a long, black creature with a sharp head, moving slowly, I should think about two knots, through the water, in a north-westerly direction, there being a fresh breeze at the time and some sea on. I could not ascertain its exact length, but its back was 20 feet, if not more, above the water, and its head, as near as I could judge, from 6 feet to 8 feet. I had not the time to make a closer

observation, as the ship was going six knots through the water, her head E. half S. and S.S.E. The creature moved across our wake, towards a merchant barque on our lee-quarter and on the port tack. I was in hopes she would have seen it also. The officers and men saw it, and [those] who have served in parts of the world adjacent to whale and seal fisheries and have seen them in the water, declare they have never seen or heard of any creature bearing the slightest resemblance to the one we saw. There was something on its back that appeared like a mane, and, as it moved through the water, it kept washing about; but before I could examine it closely it was too far astern."

The following account of a sea serpent was communicated to the *Illustrated London News* on 25 September 1853:

"We hand you the following extract from the log-book of our ship *Princess*, Captain A. K. N. Tremaine, in London Docks, 15th instant, from China, viz.: "Tuesday, July 8th, 1853; latitude (accurate) 34.56 degrees S.; longitude (accurate) 18.14 degrees E. At 1 p.m. saw a very large fish, with a head like a walrus, and twelve fins similar to those of the blackfish, but turned the contrary way. The back was from 20 feet to 30 feet long; also a great length of tail. It is not improbable that this monster has been taken for the great sea-serpent. Fired and hit it near the head with rifle ball. At eight, fresh wind and fine."

The monster was seen by the entire ship's crew, and also by Captain Morgan, a passenger.

Another sea-serpent was seen by Dr Biccard, of Cape Town, in February 1857, and again, a month later, by Mr Fairbridge and others. Dr Biccard was at the lighthouse at Green Point at about 5 pm in the afternoon of the day in question, when he was summoned by the lighthouse keeper, and the following account is in his own words:

"I proceeded to the lighthouse and from thence I saw on the water, about 150 yards from the shore, a serpent. I borrowed a rifle from Mr. Hall (the father-in-law of the lighthouse keeper), and fired at the animal. The ball fell short in front of it by about four yards. The animal did not move, and then I fired a second shot, the ball striking about one foot or one-and-a-half feet from it. The serpent then, apparently startled, moved from its position, and straightened himself out, and went under water, evidently getting out of the way. He was invisible about ten minutes, at the expiration of which interval he reappeared about 200 yards distant, and, I should say, about 40 yards farther off. He then came right on towards the place where I first saw him; but before arriving there, my son, who had joined me, fired at the animal. Unluckily the discharge broke the nipple of the rifle, and I was thus prevented from further firing. Upon reaching the place which he first occupied, and then stood right into the bay, and soon afterwards we lost sight of him altogether."

The animal was about 200 feet in length, and the head was indistinct. The body was of a dull, dark colour, except the head which was maculated with white spots. The water at that time was very calm, and the creature was seen by eight persons in all.

A young sea-serpent was actually caught and dissected by members of the Linnaean Society of Boston. Due to a number of reports of great sea-serpents seen during the

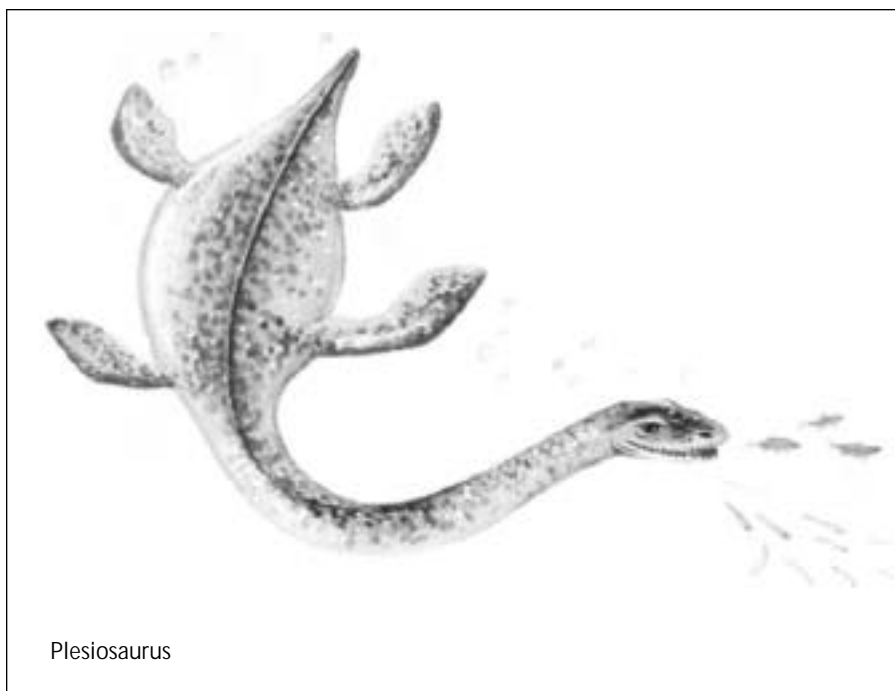

Plesiosaurus

month of August 1817 in the harbour of Gloucester, Massachusetts, the Linnaean Society appointed a committee to collect evidence with regard to the existence and appearance of such an animal. Shortly after, a report appeared, and a month later a young sea-serpent was actually caught. It was named *Scoliopterus Atlanticus*, and was killed on the seashore near Cape Ann. Following the dissection, a pamphlet was published giving details.

In its issue of 19 April 1879, the *Graphic* gave an illustration of a sea serpent seen by its correspondent, Major H. W. J. Senior, of the Bengal Staff Corps, together with a description of the monster, as it appeared to him from the poop deck of the Steamship *City of Baltimore*, on latitude 12°28'N, longitude 43°52'E. Major Senior first saw the creature about three-quarters of a mile distant, "darting rapidly out of the water and splashing in again, with a noise distinctly audible", and rapidly approaching the ship. It got within 500 yards before changing course and finally disappearing. It moved so quickly that it could not be viewed through the telescope, and no one was sure if it had scales or not. Major Senior also reported the following:

"The head and neck, about two feet in diameter, rose out of the water to a height of about twenty or thirty feet, and the monster opened its jaws wide as it rose, and closed them again as it lowered its head and darted forward for a dive, reappearing almost immediately some hundred yards ahead. The body was not visible at all, and must have been some depth under water, as the disturbance on the surface was too slight to attract notice, although occasionally a splash was seen at some distance behind the head. The shape of the head was not unlike pictures of the dragon I have often seen, with a bulldog appearance of the forehead and eyebrow. When the monster had drawn its head sufficiently out of the water, it let itself drop, as it were, like a huge log of wood, prior to darting forward under water."

Dr Hall, the ship's surgeon, and Miss Greenfield, a passenger, also saw the creature.

Much ridicule was cast upon the story of the sea serpent seen by Captain Drevar and the crew of the barque *Pauline*. The account runs as follows:

"Barque *Pauline*—July 8th, 1875; lat. 5 degrees 13' S., long. 35 degrees W.; Cape Roque, northeast corner of Brazil, distant twenty miles at 11 a.m.

"The weather fine and clear, the wind and sea moderate, observed some black spots on the water and a whitish pillar, about 35 feet high, above them. At first I took it all to be breakers, as the sea was splashing up fountain-like about them, and the pillar, a pinnacle rock bleached with the sun; but the pillar fell with a splash and a similar one rose. They rose and fell alternately in quick succession, and good glasses showed me it was a monster sea-serpent coiled twice round a large sperm whale. The head and tail parts, each about 30 feet long, were acting as levers, twisting itself and the victim around with great velocity. They sank out of sight about every two minutes, coming to the surface still revolving, and the struggles of the whale and two other whales that were near, frantic with excitement, made the sea in this vicinity like a boiling caldron, and a loud and confused noise was distinctly heard. This strange occurrence lasted some fifteen minutes, and finished with the tail portion of the whale being elevated straight in the air, then waving backwards and forwards and lashing the water furiously in the last death struggle, when the whole body disappeared from our view, going down head foremost

towards the bottom, where, no doubt, it was gorged at the serpents leisure...

"Allowing for two coils round the whale, I think the serpent was about 160 feet or 170 feet long and 7 feet or 8 feet in girth. It was in colour much like a conger eel, and the head, from the mouth being always open, appeared the largest part of the body...

"At 7 a.m., July 13th, in the same latitude, and some eighty miles east of San Roque, I was astonished to see the same or a similar monster. It was throwing its head and about 40 feet of its body in a horizontal position out of the water, as it passed onwards by the stern of our vessel...

"I was startled by a cry of 'There it is again,' and, a short distance to leeward, elevated some 60 feet in the air, was the great leviathan, grimly looking towards the vessel...

"A vessel, about three years ago, was dragged over by some sea-monster in the Indian Ocean."

Due to the sheer number of doubters of such an outrageous story, the Captain, accompanied by a number of his officers and crew, appeared before Mr Raffles, stipendiary magistrate, at the Dale Street Police Court, Liverpool, and made a declaration. This shorter account was then signed by George Drevar, Horatio Thompson, Henderson Landello, Owen Baker and William Lewan. In all, three declarations were made, one for each sighting.

Captain Hassel, of the barque *St. Olaf*, from Newport, two days before her arrival at Galveston, Texas, on 13 May 1872, saw a large sea-serpent lying on the surface of the water. Seventy feet of it were visible and it had four fins along the back. It was about six feet in diameter, and was of a greenish-yellow colour with brownish spots over the upper part.



In June 1877, the officers and crew of the Royal yacht *Osborne* encountered a sea monster off the coast of Sicily. Lieutenant Haynes described it thus:

"My attention was first called by seeing a long row of fins appearing above the surface of the water at a distance of about 200 yards from the ship, and away on our beam. They were of irregular heights and extending about 30 feet or 40 feet in line. In a few seconds they disappeared, giving place to the forepart of the monster. By this time it had passed astern, swimming in an opposite direction to that we were steering, and as we were passing through the water at ten-and-a-half knots I could only get a view of it 'end on'. The head was bullet-shaped, and quite 6 feet thick, the neck narrow, and its head was occasionally thrown back out of the water, remaining there for a few seconds at a time. It was very broad across the back or shoulders, about 15 feet or 20 feet, and the flappers appeared to have a semi-revolving motion, which seemed to paddle the monster along. They were about 15 feet in length. From the top of the head to the part of the body where it became immersed, I should consider 50 feet, and that seemed about one-third of the whole length. All this part was smooth, resembling a seal. I cannot account for the fins, unless they were on the back below where it was immersed."

Captain R. J. Cringle, of the Steamship *Umfuli*, one of the ten vessels of the Natal Line belonging to Bullard, King and Company, entered the following in the ship's log:

"SS. *Umfuli*, Monday, Dec. 4th, 1893, 5.30 p.m., lat. 23 deg. N., long. 18 deg. W. — Sighted and passed, about 500 yards from ship, a monster fish of serpentine shape, about 80 feet long, with shining skin, and short fins, about 20 feet apart, on the back; in circumference, about the dimensions of a full-sized whale."

The position indicated was off the coast of Africa, a little south of the Canary Islands. When questioned further, the captain said that all his crew and the passengers had seen it. He had this to add:

"...and this thing, whatever it was, was in sight for over half an hour. In fact, we did not lose sight of it until darkness came on.

"When we first saw it I estimated that it would be about 400 yards away. It was rushing through the water at great speed, and was throwing water from her bows. I saw full 15 feet of its head and neck on three occasions. They appeared and disappeared three times. The body was all the time visible."

After likening the body to a hundred-ton gun partly submerged, with three distinct humps or swellings above the waves, he then continued:

"The base, or body, from which the neck sprang was much thicker than the neck itself... I turned the ship round to get closer to it, and got much nearer than we were at first; but the sun was setting."

The creature appeared to have smooth skin, and was dark brown in colour. The ship was so near it at one time that a passenger, Mr Kennealy, said he could hear the creature hiss, but the first officer claimed that the sound was nothing but the noise from the water at the bows. Mr Kennealy may have immortalised himself if only he had taken the trouble to use the camera he had on board.

Dr Farquhar Matheson, of London, had a still closer view of a similar creature. This happened in September 1893 while Dr

Matheson was sailing with his wife on Loch Alsh which separates the Island of Skye from the mainland. His own account runs as follows:

"The time was between one and two when suddenly I saw something rise out of the Loch in front of us, a long, straight, neck-like thing as tall as my mast.

"It was then 200 yards away and was moving towards us. Then it began to draw its neck down, and I saw clearly that it was a large sea-monster of the saurian type, I should think. It was brown in colour, shining, and with a sort of ruffle at the junction of the head and neck. I can think of nothing to which to compare it so well as the head and neck of the giraffe, only the neck was much longer, and the head was not set upon the neck like that of a giraffe; that is, it was not so much at right angles to it as a continuation of it in the same line. It moved its head from side to side, and I saw the reflection of the light from its wet skin."

Dr Matheson saw no scales on the creature, just a perfectly smooth surface. It was in sight for about two minutes and then disappeared. Then it rose again three different times, at intervals of two or three minutes. It stood perpendicularly out of the water and seemed to look round.

"When it appeared the second time it was going from us, and was travelling at a great rate. It was going in the direction of the northern outlet of the Loch, and we were sailing in its wake; I was interested, and followed it. From its first to its last appearance we travelled a mile, and the last time we saw it it was about a mile away.

"I saw no body, only a ripple of the water where the line of the body should be. I should judge, however, that there must have been a large base of body to

support such a neck... An eel could not lift up its body like that, nor could a snake."

Despite suggestions that it was an optical illusion, Dr Matheson and his wife stuck to the story.

Curiously, Dr Matheson's description of the sea serpent sounds surprisingly close to that of a periscope. When it came to submarines, at that time Britain lagged far behind the rest of the world, but France, Germany and America were all investing large sums in their development. Could that long neck and head, that turned this way and that, possibly have been the periscope of a foreign submarine doing a little spying?

References

- Dunn, Matthias, *Studies Under The Sea*, Hazell, Watson & Viney, 1901.
- Story, Alfred T., *The Sea-Serpent*, Newnes, 1895.

About the Author:

C. D. Pollard is a former second-hand book dealer turned full-time writer, whose articles and short stories have been published in over 30 magazines in the UK, France, USA and, now, Australia and New Zealand. His first book, *Classic Tastes*, part of a series, is due to be published by Pipers' Ash Ltd, UK, in late 1997.

Mr Pollard has a peculiar obsession with the Victorian and Edwardian periods, particularly with rare literature and some of the more unusual goings-on of those times, be they Fortean or just plain eccentric. Working from his base in a small English village on the edge The Black Country, his aim is to rekindle the public's interest in many of these strange stories.

"It was then 200 yards away and was moving towards us. Then it began to draw its neck down, and I saw clearly that it was a large sea-monster of the saurian type..."



REVIEWS

BOOKS

Reviewed by Ruth Parnell

PARADIGM WARS: Worldviews for a New Age

by Mark B. Woodhouse

Publisher: Frog, Ltd, Berkeley, CA, USA, 1996

ISBN 1-883319-42-0 (632pp s/c)

Price: AUD\$35.00; STG£18.99 + £2.00 p&h; USD\$22.50 + p&h

Available: **Australia**—Sydney Esoteric Bookshop, ph (02) 9212 2225; **UK**—Airlift Book Co., ph 0181 804 0400;

USA—Adventures Unlimited, ph (815) 253 6390.

If this book's title, *Paradigm Wars*, may seem to have negative connotations, the author makes no apologies. As a realist and an optimist he sees that the state of the world will get much worse before it gets better—but he does see a much rosier future a little further down the track.

Author Mark Woodhouse, a philosopher and academic, juxtaposes two world views: an old paradigm and a new, both in a state of transition. He brings balance to the issues in that he gives valid reasons for both Old and New Age perspectives reassessing themselves, realising full well that this requires dealing with guilt, fear, control and frustration on both sides.

Woodhouse applies his detailed critical analysis to a vast range of perspectives, from the social to the personal, the physical to the mystical, the mechanistic to the holistic, the materialistic to the energetic, and so on. His courageous critique treads that fine line between the intellectual and the intuitive—both in terms of his target audience and

credibility amongst the less-enlightened of his peers—but this ability is all part of handling a major paradigm shift in consciousness on all levels from the personal to the planetary—and beyond.

Woodhouse believes we humans are soon to take a giant leap towards our galactic destiny, but how we handle it depends on freeing any restrictive mindsets we may have.

CoEVOLUTION

by Alec Newald

Publisher: NEXUS Publications,

Mapleton, Qld, Australia, 1997

ISBN 0-9587093-0-0 (215pp s/c)

Price: AUD\$20.00; NZD\$25.00 + p&h; STG£11.50; USD\$16.95 + p&h

Available: **Aust**—NEXUS Magazine, ph (07) 5442 9280; **New Zealand**—NEXUS

Office, ph (09) 416 7320; **UK**—NEXUS

Office, ph 01342 322854; **USA**—

Adventures Unlimited, ph (815) 253 6390.

It would be remiss not to admit to some degree of bias towards this book (previewed last issue), as editor Duncan Roads considered Alec Newald's story so mind-boggling that he decided publish it, and gave this reviewer the opportunity to edit it. In our view, this book will go down in history, for Alec has gone where very few have ever had the opportunity to tread.

In late February 1989, Alec arrived in Auckland after what should have been a three-hour drive from Rotorua in New Zealand. Soon he realised he had lost ten days but had no idea how that could have happened. Through a series of revelatory dreams and later, hypnotherapy sessions, Alec was able to piece together the puzzle.

Alec had spent those 10 days in the com-

pany of some advanced, benevolent extraterrestrials, travelling to and from their home planet and participating in their day-to-day activities. What he learned of these people, their language, lifestyle, technology, history and their plans is nothing short of mind-blowing, for these aliens have a special relationship with Earth's and humanity's past and future history.

All hell broke loose not long after Alec's return to Earth when he was visited by secret government-connected 'scientists', demanding to know the details of his trip. Refusing to cooperate, Alec soon found himself the victim of a sinister set-up.

In *CoEvolution*, Alec suggests many intriguing links that make his experience all the more significant, and warns that our lives are soon to undergo major changes.



REVIEWS



BOOKS

THE OCTOPUS: Secret Government and the Death of Danny Casolaro by Kenn Thomas and Jim Keith

Publisher: Feral House, OR, USA, 1997
ISBN 0-922915-39-3 (181pp s/c)
Price: AUD\$30.00; NZD\$39.00 + p&h;
STG£13.99 + £1 p&h; USD\$19.95 + p&h
Available: **Aust**—NEXUS Magazine, ph
(07) 5442 9280; **NZ**—NEXUS Office, ph
(09) 416 7320; **UK**—Counter
Productions, PO Box 556, London SE5
ORL; **USA**—Adventures Unlimited, ph
(815) 253 6390.

In just over a year of solid research, investigative journalist Danny Casolaro had started to tweak the tentacles of a "the Octopus"—a shadowy secret government/intelligence cabal that was the subject of his impending book. He died under suspicious circumstances in August 1991.

What exactly had Casolaro netted that may have led to his demise? In an attempt to answer this, authors Kenn Thomas and Jim Keith have made detailed studies of Casolaro's notes and interviewed family and various associates (some of them rather shady types). Their task in piecing together the puzzle has not been easy, for Casolaro uncovered such a web of intrigue that *any* connection might have been responsible for that final act—one which was officially declared a "suicide". (See extracts published in NEXUS 4#01, 4#02.)

Casolaro had identified key Octopus members and their links to a string of covert activities, e.g., the Kennedy assassination, Watergate, the "October Surprise", Iran-Contra, the Inslaw PROMIS software case,

banking scandals, 'black' projects, and the Cabazon/Wackenhut joint venture. The authors conclude that this latter connection was occupying much of Casolaro's attention at the time of his death—and that the perpetrators acted to 'neutralise' him before he got any closer to the truth.

Danny Casolaro's death was a tragedy, but without other intrepid researchers like Thomas and Keith staying on the case we'll never get close enough to know how big the picture really is.

ON THE TRACK OF WATER'S SECRET: From Viktor Schauberger to Johann Grander by Hans Kronberger & Siegbert Lattacher

Publishers: Uranus Verlags gmbh ,
Vienna, Austria, 1995; Books of
Revelation, Victoria, Australia, 1996
ISBN 3-901626-03-4 (176pp s/c)
Price: AUD\$23.00 inc. p&h;
AUD\$26.00 air to NZ; AUD\$30.50 air to
UK/Europe; AUD\$29.50 airmail to
USA/Canada
Available: **Australia**—Books of
Revelation, PO Box 199, Warrandyte,
Victoria 3113, ph +61 (0)3 9844 4492,
fax +61 (0)3 9844 4884.

Because water is a liquid crystal, its molecular lattice structure is capable of storing memory. But most of us consume and bathe in 'sick' waters with collective bad memories! If everything has vibration, it follows that when toxic chemicals get into a water supply their frequencies oscillate and stay 'magnetised' within the water in spite of any 'purification' techniques applied.

Austrian inventor and naturalist Johann Grander has devoted many years to develop-

ing his accidental discovery, based on observation of natural rhythms (just as his predecessor, Viktor Schauberger, did). He found that by applying spiral motion to water and subjecting it to high-frequency vibrations (around 100,000 Hz) through magnetism, all traces of deleterious energies are neutralised and the water is not only reprogrammed but revitalised. (See article in this issue.)

In their story of Grander's 'grand vision', *On the Track of Water's Secret*, environmental journalist Hans Kronberger and water researcher Siegbert Lattacher present astounding case histories and photos confirming the efficacy of Grander's "Living Water" in achieving glowing health for humans, animals and plants. Grander's tech-

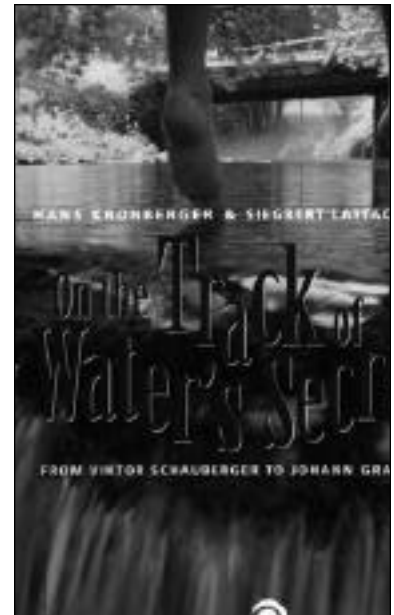



REVIEWS

nologies also have exciting prospects in water treatment, medicine, industry and transport—where a combustion device has already undergone successful trials.

Technologies like these are the way of the future, now, and by all accounts they can greatly benefit our lives and our world.

WHEN THE COMET RUNS: The Prophecies for the Millennium by Tom Kay

Publisher: Hampton Roads, USA, 1997
ISBN 1-57174-059-7 (239pp s/c)
Price: AUD\$26.00; NZD\$29.95;
STG£10.99 + £1.10 p&h; USD\$12.95
Available: **Aust**—Cameron Books, 68
Winbourne Rd, Hazelbrook, NSW 2779,
ph (047) 58 7676, fax (047) 58 9047;
NZ—Peaceful Living, ph (07) 571 8105;
UK—Airlift Book Co., ph 0181 804 0400;
USA—Hampton Roads Publishing Co.,
134 Burgess Lane, Charlottesville, VA
22902, ph (804) 296 2772, 1-800 766
8009, fax (804) 296 5096.

We are indeed poised at the crossroads, millennially speaking. Here we are, with the possible fulfilment of the prophecies upon us—many more than had to be contended with the last time around, a thousand years ago. As author Tom Kay demonstrates, so many of these prophecies point to the same thing, the same time of reckoning, similar fiery events in the sky, travesty upon the lands and oceans, and times of spiritual transformation.

By taking these prophecies on board, we risk their eventuality; by ignoring them we may be doing so at our peril. But if the Great Comet does come, we may be powerless to deal with the effects of its presence. It's hard enough dealing with what it por-

tends! As for when, well, at the time of writing, Comet Hale-Bopp is bearing down upon us, and by all accounts it's more than just your average comet. Yet, there is always a Greater Comet to come...

These perspectives and more are given a discerning critique by Tom Kay in *When the Comet Runs*. There's an urgency about his connections, such as in his analysis of the prophecies of Mother Shipton, Edgar Cayce and the *Grail Message*, that demands attention—lest it all be too late. Reiterating the messages of modern-day seers like Aron Abrahamsen and Gordon-Michael Scallion, Kay takes us to where 'end times' become 'new beginnings'. These times may be sooner than we think.

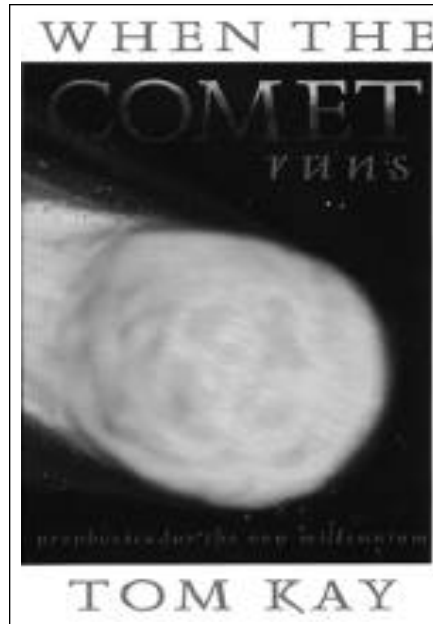

WIZARD: THE LIFE AND TIMES OF NIKOLA TESLA—Biography of a Genius by Marc J. Siefer

Publisher: Birch Lane Press/Carol Publishing Group, NJ, USA, 1996
ISBN 1-55972-329-7 (540pp h/c)
Price: AUD\$60.00; STG£ poa;
USD\$32.00; CAN\$41.95
Available: **Aust**—Cameron Books, ph
(047) 58 7676, fax (047) 58 9047; **UK**—
Counter Productions, PO Box 556,
London SE5 ORL; **USA**—Carol Publishing
Group, 120 Enterprise Ave., Secaucus, NJ
07094; **Canada**—Canadian Manda
Group, Toronto, Ontario.

Exactly 101 years ago, genius inventor Nikola Tesla (1856-1943) announced to the world through the New York press that, "If there are intelligent inhabitants of Mars or any other planet, it seems to me that we can do something to attract their attention..."

Indeed, he had been working on just that in his spare time, for this man was a modern Leonardo da Vinci with a string of patented inventions, including the AC motor, already to his credit.

This new Tesla biography, *Wizard*, is seriously researched and utterly absorbing, with chapters charting all the stages of Tesla's life. Author Mark Siefer, a psychology lecturer and graphologist, has been delving into Tesla's life, times and inventions since the late 1970s, and though several other biographies have since been written, this treatise does draw on never-before-published documents, letters and interviews and contains some rather rare photographs.

Siefer treats his prodigious subject with sympathy and realism, for Tesla was an eccentric with grand, achievable visions whose tumultuous path often saw him fêted

REVIEWS



by the rich and powerful and then rejected, unable to pay years of hotel bills.

Tesla was truly a man way ahead of his time, for few are blessed enough to be able to declare, as he did in his 1919 autobiography, that "for many years my life was little short of continuous rapture."



MYSTERY CITIES OF THE MAYA by Thomas Gann

Publisher: Adventures Unlimited Press, Kempton, IL, USA, 1997 (first published 1925, G. Duckworth, London, UK)
ISBN 0-932813-17-8 (252pp s/c)
Price: AUD\$25.00; NZD\$34.00 + p&h; USD\$16.95 + p&h

Available: **Aust**—NEXUS Magazine, ph (07) 5442 9280; **NZ**—NEXUS Office, ph (09) 416 7320; **USA**—Adventures Unlimited, ph (815) 253 6390.

First published in 1925, *Mystery Cities of the Maya* is the story of Thomas Gann's

early 1920s explorations and adventures around the Caribbean and the jungles of Central America, especially Belize and the unique Mayan city of Lubaantun which he first investigated in 1903.

Gann was an archaeologist, a member of the Maya Society and a keen observer of local customs, realising they revealed much of significance about people and their history. In this book he describes Mayan stepped pyramids, burial mounds, stelae, underground passages, glyphs and lost artefacts, "Devil Dance" masks and day-to-day religious and social rituals, and supports his narrative with classic photographs, maps and diagrams of the day.

In 1924 and 1925, Gann joined his explorer friend Mike Mitchell-Hedges on an expedition to Lubaantun, where the famed Crystal Skull would be discovered some time before the three-year dig was over. While they made some remarkable discoveries, including evidence of three different periods of occupation at the site, their expedition was cut short due to sickness in the camp. All part for the course for intrepid explorers in search of Atlantis!

Much has been discovered about the Mayan civilisation since Thomas Gann wrote this book, but Gann's reports constitute an important contribution to what is now a more solid body of knowledge.

HEALING SOUNDS: The Power of Harmonics

by Jonathan Goldman

Publisher: Element Books, USA, UK, Australia, 1992, 1996 rev. ed.
ISBN 1-85230-848-6 (188pp s/c)
Price: AUD\$24.95; NZD\$39.95; STGE9.99; USD\$14.95; CAN\$19.99

Available: **Aust**—Sydney Esoteric Bookshop, ph (02) 9212 2225; **NZ**—Penguin, ph (09) 444 4965; **UK**—Element Books, ph 01747 851339; **USA**—Element Books, PO Box 830, Rockport, MA 01966.

The efficacy of sound healing is being increasingly recognised worldwide as age-old Hermetic principles like "All is Vibration" are translated for a new age where science and spirituality are aligned.

To sound-healer and musician Jonathan Goldman, sound has the ability to affect us on all levels—the spiritual as well as the physical, emotional and mental. Thus, sound not only has healing abilities, but profound transformational powers which can alter consciousness. No small wonder, then, that specific chanting/toning techniques are used in most existant ancient cultures on Earth, from shamanic Aboriginal and Siberian peoples to Tibetan monks with their "Deep Voice" chanting.

In this revised edition of *Healing Sounds*, Goldman has written a new introduction to acknowledge the benefits he received in his 1991 sessions with monks visiting from the Drepung Loseling Monastery in Tibet. It was then that he was authorised to teach the "One Voice Chord" technique.

Goldman's recent progress in harmonics has given him new insights into how anything can be accomplished through the right vibration. In our ever-changing reality, Goldman sees sound playing a key role in adjusting to multidimensional frequency shifts, so he encourages people to gather together to create sacred sound and "a morphic field resonance through a unified consciousness". He includes a variety of healing, chanting and overtone exercises that are bound to raise those vibrations!



REVIEWS

BELOVED VISITORS

by Cherie Sutherland, Ph.D.

Publisher: Bantam, Australia & New Zealand, 1997

ISBN 0-7338-0020-3 (262pp s/c)

Price: AUD\$18.95; NZD\$21.95

Available: **Aust**—Sydney Esoteric Bookshop, ph (02) 9212 2225; **NZ**—Transworld, ph (09) 415 6210.

The thought of losing a child is unbearable, but actually to have one's child die is a grief which few parents can speak about and often never come to terms with. By writing this book, Cherie Sutherland aims to give hope to grieving parents.

Sutherland, a Sydney-based author and sociology research fellow, was conducting research into near-death experiences when she discovered it was fairly common for grieving parents to have had premonitions prior to their children's death, and receive signs and visitations after their departure.

Beloved Visitors was thus born out of a study among parents whose children's lives were tragically cut short. The ages of these children ranged from only days old to late-30s, and the circumstances included car accident, cot death, drowning, illness, murder and suicide. Sutherland's approach assists the bereaved to work through their grieving, to a point where they make a choice to accept the death and emerge from the pain, in a sense strengthened by their ordeal and enriched with new insights into the reality of life beyond death.

Sutherland focuses on the experiences of 15 parents (singles and couples) who relate some astonishing and truly heart-wrenching personal accounts. She sees each of their experiences as a "hero's journey" of courage and compassion that can help us all transform our understanding of life, death and beyond.



DESIGN ECOLOGY

by Michael Riversong

Publisher: Borderland Sciences Research Foundation, CA, USA, 1996

ISBN 0-945685-17-3

Price: AUD\$27.00; NZD\$36.00 + p&h; USD\$16.95 + p&h

Available: **Aust**—NEXUS Magazine, ph (07) 5442 9280; **NZ**—NEXUS Office, ph (09) 416 7320; **USA**—Adventures Unlimited, PO Box 74, Kempton, IL 60946, ph (815) 253 6390.

If you are yet to incorporate harmonious design principles and strategies into your life, this comprehensive resource book, *Design Ecology*, is a must to study. Author Michael Riversong is a multi-talented musician and composer, has a Chinese language BA, and is a writer on subtle energies for such journals as *Borderlands* and *Extraordinary Science*. His design ecology practice, Quality Environmental Assessments, does surveys and 'clearings' of homes and offices.

Riversong's design ecology is a blend of Chinese *feng shui* and German *bau-biologie* concepts and techniques. He gets down to the physics of why and how *feng shui* works, and even uses these principles to analyse the workability of cities and the sacredness of sites in Europe, UK and US.

What *bau-biologie* or design ecology has to offer in the overall equation is attention to geobiological and geomagnetic aspects as well as energy-conservation and health-and-safety considerations. In one section, Riversong gives useful hints on dealing with the invisible environment, and in another he explains how to overcome the chronic effects of toxic chemicals at home.

Riversong devotes the final section to innovative solutions, e.g., using *feng shui* to change subtle energies; assembling a design ecology toolkit (including EM field meters and other gadgets); creating a backyard medicine wheel; designing field modulators that can affect local weather; and finding new ways to measure *ch'i* energy.

TOOTH TRUTH: A Patient's Guide to Metal-Free Dentistry

by Frank J. Jerome, D.D.S.

Publisher: ProMotion Publishing, CA, USA, 1995

ISBN 1-887314-08-3 (352pp s/c)

Price: AUD\$39.00; USD\$19.95 + p&h

Available: **Aust**—Natural Therapy Products, PO Box 252, Turrumurra, NSW 2074, ph (02) 9983 1299; **USA**—ProMotion Publishing, 3368F Governor Drive, #144, San Diego, CA 92122, ph (619) 490 1400; 1-800 231 1776.

Modern dentistry is promoting widespread 'truth decay', for much has been published

REVIEWS



BOOKS

about hazardous dental practices since earlier this century, yet that information is not common knowledge.

As Frank Jerome explains in *Tooth Truth*, members of the American Dental Association have colluded in preventing important dental facts from becoming widely known and safer dentistry practices from becoming more widely sought and used. With this book he fights back against the dental establishment, aiming to fill those gaps in the layperson's knowledge and encourage the 'patient' out of complacency towards self-responsibility.

Dr Jerome argues that unless people are educated about the health dangers associated with mercury amalgam fillings (such as mercury poisoning, and electric discharges that disrupt the immune system), with crowns and root-canal fillings, with tooth-replacement techniques and fluoride treatments, they cannot make informed dental or general health decisions. His easy-to-understand format gives the run-down on the problems, the stop-gap solutions often adopted by shortsighted dental 'professionals', and the holistically-based alternatives that aren't widely recognised.

Sometimes the most important advice can be as basic as just having to change diet—but this may not be the truth people want to hear. This is a book with bite!

PYRAMID POWER: THE MILLENNIUM SCIENCE

by Dr G. Pat Flanagan

Publisher: Earthpulse Press, Inc., Anchorage, Alaska, USA, 1997 (first published 1973)

ISBN 0-9648812-6-8 (182pp s/c)

Price: AUD\$26.00; NZD\$34.00 + p&h ; STG£13.50; USD\$14.95 + p&h

Available: **Aust**—NEXUS Magazine, ph (07) 5442 9280; **NZ**—NEXUS Office, ph (09) 416 7320; **UK**—NEXUS Office, ph 01342 322854; **USA**—Adventures Unlimited, ph (815) 253 6390.

Patrick Flanagan's first book, *Pyramid Power*, became a bestseller when it was released in 1973, and his research has since inspired a thousand-and-one offshoots. Just republished, this landmark work is a necessary part of any new millennium science researcher's library. If you're not already familiar with it, we recommend it because Patrick's theories and experiments concerning vortex energy, pyramid power and the mechanical ether still resonate strongly.

Dr Flanagan takes us back to basics, to the universal energy fundamentals that were so integral to ancient cultures, such as in Egypt, India, Tibet, China and Hawaii. Each had or

has its own word for the essential life-energy—and practices for tapping into it. What he reveals in a later section on theories of energies is a new-physics spin on age-old systems, with the future of science being the integration of the two.

Patrick Flanagan describes his findings on the sacred geometry and mathematics of the Great Pyramid and the science of pyramid power, but not before taking the reader on a side trip with his earlier Neurophone invention, revealing that it also makes telepathic communication possible.

Dr Flanagan's pyramid research subjects were wide-ranging—featuring razor blades, kirlian measurements, plant growth, alpha rhythms, effects on food, energy plates, psychotronic devices—and are highly illustrative of the promise of science for the next millennium.

UFOs AND ANTI-GRAVITY: PIECE FOR A JIG-SAW

by Leonard G. Cramp

Publisher: Adventures Unlimited Press, Kempton, IL, USA, 1996 (first publ. 1966)

ISBN 0-932813-43-7 (388pp s/c)

Price: AUD\$26.00; NZD\$34.00 + p&h; STG£14.95; USD\$16.95 + p&h

Available: **Aust**—NEXUS Magazine, ph (07) 5442 9280; **NZ**—NEXUS Office, ph (09) 416 7320; **UK**—NEXUS Office, ph 01342 322854; **USA**—Adventures Unlimited, ph (815) 253 6390.

There's a certain irony to the introduction of Leonard Cramp's classic 1966 treatise, *UFOs and Anti-Gravity* (now republished). Cramp was reflecting on the 18 years since the UFO phenomenon had entered the public

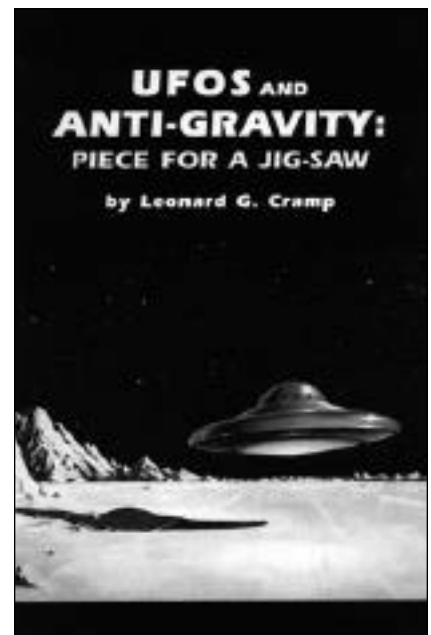



REVIEWS

mind and the dozen-odd years since the publication of his seminal work, *Space, Gravity and the Flying Saucer*, in 1954.

Twelve years had passed since Cramp had examined two famous photos of alleged UFOs—the Lake Coniston, UK, saucer and the Adamski craft—and proposed his theories of UFO propulsion based on observation, deduction and the application of the inverse square law. But he was still no closer to being able to prove his anti-gravity propulsion theories and, indeed, to being taken seriously by scientists, the media or the public.

Should we be surprised at how little progress has been made in the meantime in openly putting Cramp's theories to the test, in an attempt to understand the phenomenon? In the ensuing 30 years, the UFO mystery has only deepened.

Leonard Cramp's ideas and experiments still carry weight, and seem to have been corroborated in many UFO sightings in the meantime. His scientific and technical insights have encouraged new ways of thinking about reality, both physical and subtle. UFO and anti-gravity enthusiasts will not take this book lightly!

SKYWATCHERS, SHAMANS & KINGS by E. C. Krupp

Publisher: John Wiley & Sons, Inc., NY, USA, 1997

ISBN 0-471-04863-1 (364pp h/c)

Price: AUD\$39.95; NZD\$52.00;

STG£19.99 + £2 p&h; USD\$27.95;

CAN\$39.50

Available: **Aust**—Sydney Esoteric Bookshop, ph (02) 9212 2225; **NZ**—J. Wiley, ph (06) 355 1298; **UK**—J. Wiley & Sons, ph 01243 779777; **USA**—John Wiley & Sons, ph (212) 850 6000.

In his extensive career in astronomy, author E. C. Krupp has visited more than 1,300 ancient sites around the world. His latest book, *Skywatchers, Shamans and Kings*, features an extensive collection of these sites, backed up with archaeological and mythological evidence for the cosmological world-views existent at those sites.

According to Krupp's thesis, astronomical knowledge confers power. The close relationship these ancient cultures had with the sky was reflected in their sacred landscapes, their myths and their rituals. From their observations they developed calendar systems that were integral to the success of their economies and societies. Their temples, tombs, inscriptions, sculptures, paintings would often mirror the cosmos, allowing the people a powerful connection with the sky gods in the stars.

To Krupp, though, the sky god myths so common to ancient cultures are just that—

myths. It's hard to believe, considering the evidence that some civilisations, like the Sumerians, knew of planets not visible to the naked eye, that these myths were not somehow based on reality. Yet Krupp discounts the suggestion that these 'sky gods' may have been extraterrestrial visitors.

Touching on ancient cultures including the Egyptian, Assyrian, Mongolian, the African Dogon, Çatal Höyük in Turkey, the Mayan, Pueblo, the Khmer, and so many more, Krupp has assembled fascinating material, but some readers will be inspired to draw different conclusions.

THE POLTERGEIST MACHINE: The Hutchison Effect—A Lift and Disruption System by Albert Budden

Publisher: Discovery Times Press,
Middlesex, UK, 1996

ISBN n/a (32pp sp/b)

Price: STG£10.00 in UK; foreign orders
add STG£2.00 p&h

Available: **UK**—Discovery Times Press,
17 Brook Road South, Brentford,
Middlesex TW8 ONN, ph +44 0181 560
9497.

In 1981, Canadian physicist and inventor John Hutchison first demonstrated 'ghost in the machine' effects in his laboratory. With his device—a collection of electronic gadgetry whirring away in unison—he produced effects such as levitation of heavy objects, spontaneous fires, mirrors smashing from a distance, steel bars shredding, lights in the air and other high-jinks.

Meantime, across the Atlantic in England, Albert Budden was conducting paranormal research which led him to look into haunted houses and the poltergeist phenomenon. In time, he proposed a theory that much of this 'supernatural' activity is electromagnetic in nature and possibly a function of environmental EM disturbances, natural and/or man-made.

When he discovered John Hutchison's research a few years ago, Budden saw obvious parallels between his own observations of the phenomenon and Hutchison's ability to reproduce classic poltergeist-type effects within a laboratory-based apparatus. (See story in NEXUS 4#01.) The result of their collaboration is this manual which includes Hutchison's own description of his apparatus (which employs magnets, Tesla coils and a Van de Graaf generator), as well as specification notes and technical diagrams.

Hutchison continues his experiments today, despite past setbacks with sabotage and harassment by authorities (as will be explored in Budden's forthcoming biography of the inventor). Obviously his work is being taken seriously in certain quarters.

REVIEWS



BOOKS

WITNESSED: The True Story of the Brooklyn Bridge Abduction by Budd Hopkins

Publishers: Pocket Books, NY, USA, 1996; Bloomsbury, UK, 1997
ISBN 0-7475-3322-9 (408pp s/c)
Price: AUD\$21.95; NZD\$n/a;
STG£11.99 + £1.50 p&h; USD\$23.00;
Available: **Aust**—Cameron Books, ph (047) 58 7676; **NZ**—Hodder Moa Beckett, ph (09) 478 1000; **UK**—Bloomsbury; **USA**—Pocket Books

Witnessed is Budd Hopkins' long-awaited book describing the abduction of Linda Cortile by aliens on 30 November 1989. Several eyewitnesses (some anonymous) eventually contacted Hopkins, the well-known abduction researcher, to confirm the event. Linda was seen being 'beamed' out of the bedroom window of her 12th-storey apartment in the middle of New York City, not far from Brooklyn Bridge. She was accompanied by three "Grey-type" aliens and taken aboard their hovering disc-shaped craft which then moved toward the bridge.

Two witnesses who confirmed the event were 'policemen' driving a highly-placed international figure at the time. They all saw the event at quite close range, for their car had 'died', presumably due to local electromagnetic disturbances caused by the UFO's presence. The 'policemen' made contact with Linda shortly after the incident out of concern for her safety, but the senior 'official' still refuses to go public.

Linda survived to tell her tale, much of it recovered in hypnotherapy sessions conducted by Hopkins, sometimes in the presence of a trained psychologist. Hopkins has included transcripts of those sessions, which reveal many puzzling and frightening situations during Linda's abduction.

Linda's story (with Hopkins' faithful reporting) is a milestone in ufology, particularly for the independent eyewitness accounts and visual representations.

VIDEOS

Reviewed by Duncan Roads

JURASSIC ART

Producer: BC Video, USA, 1997
Price: AUD\$45.00; NZD\$65.00 + p&h;
STG£21.00; NFL£55.00; USD\$19.95 (48mins; PAL/VHS; USA: NTSC/VHS)
Available: **Aust/NZ/UK/Eur**—NEXUS offices; **USA**—Adventures Unlimited, ph (815) 253 6390.

Jurassic Art is the third video in the Mysterious Origins of Man Series. It investigates two controversial collections of art,

which show humans with dinosaurs.

Thirty years ago, thousands of images inscribed on stones were found near the mysterious Nazca lines in Peru. Dubbed the "Ica stones", these included realistic depictions of stegosaurus and pterodactyls, ancient pilots flying strange craft above herds of dinosaurs, and advanced surgical procedures, including one that appears to be a heart transplant.

The Acámbaro collection, found 3,000 miles away in Mexico, consists of 33,000 clay figurines depicting fantastic creatures resembling extinct dinosaurs, mythological figures similar to those in Egypt, and reptilian creatures involved in strange interactions with humans.

The video takes an unbiased look at evidence on both sides of the argument: are they authentic and millions of years old, or are they elaborate hoaxes?

THE QUEST FOR KNOWLEDGE SERIES Volumes One, Two, Three

Producer: Avante Garde Ltd, UK, 1996
Price: AUD\$45.00 ea (3 for AUD\$120); NZD\$59.95 ea + p&h; STG£21.00 ea; NFL£55.00 ea; USD\$19.95 ea + p&h
Available: **Aust/NZ/UK/Eur**—NEXUS offices; **USA**—Adventures Unlimited, ph (815) 253 6390.

In May 1996, *Amateur Astronomy & Earth Sciences (AA&ES)* Magazine assembled a fine collection of speakers for a conference in London. The three videos in The Quest For Knowledge Series feature many of the leading proponents of the theory that mankind has been on Earth a lot longer, and has been more technologically advanced, than recognised by modern science.

Video One (130 mins): Includes **Robert Bauval** and **Graham Hancock** launching their bestselling *Keeper of Genesis*, and making important announcements about excavations beneath the Sphinx and the opening of the shaft door in the Great Pyramid.

Video Two (126mins): Includes **John Anthony West**, leading researcher into the age of the Sphinx, with the latest controversial evidence; and **John Lash**, a comparative mythologist who talks about new evidence of an advanced society buried in myth and in reality—the true Atlantis?

Video Three (120mins): Includes **Peter Whitehead**, author of *The Risen*, a new novel that combines technology and myth to transport the characters back and forth through time (Peter believes that the ancient Egyptians used a similar holographic method); and **Andrew Collins**, author of *From The Ashes Of Angels*, who tells of his search for an ancient race of beings who were and, literally, are out of this world.



REVIEWS

AUDIO

Reviewed by Richard Giles

WINDJANA

by Tony O'Connor

Producer: Studio Horizon, Nambour, Qld, Australia, 1996

Price: AUD\$18.95, USD\$9.95 (cass); AUD\$25.95, USD\$15.95 (CD)

Available: **Australia**—Steve Parish Publishing, ph (07) 3257 3257; **USA**—Aussie Trader, ph (504) 769 6154.

Australia's maestro of ambience has released another album to add to the O'Connor collection. *Windjana* is a return to some of his great compositions (like *Mariner* and *Tales of the Wind*) from the earlier Studio Horizon period. It conveys the timeless feel of Australia's Kimberley landscape, and is imbued with Tony's superb ability to fill a space with ambient peace and carefreeness. Tony is joined on the album by local didgeridu legend Matt Pickup. Highly recommended.

MY PEOPLE

by Joe Zawinul

Producer: Joe Zawinul for Escapade Music, Conshohocken, PA, USA, 1996

Price: AUD\$19.95, USD\$9.98 (cass); AUD\$29.95, USD\$15.98 (CD)

Available: **Aust**—MRA Entertainment, ph (07) 3849 6020; **USA**—Escapade Music, ph (610) 825 9698.

Joe Zawinul, of Weather Report fame among other things, has brought together for this album many top vocalists and musicians from all corners of the world—Mali, Turkey, Venezuela, Cameroon, Siberia, India, Israel, Peru, and on it goes. Zawinul was a 'world-music man' of many cultures long before it became the flavour of the '90s. *My People* is a polymorphous mix of African, South American and Caribbean influences. Great rhythms and healthy improvisations make this a must for any world-music collection.

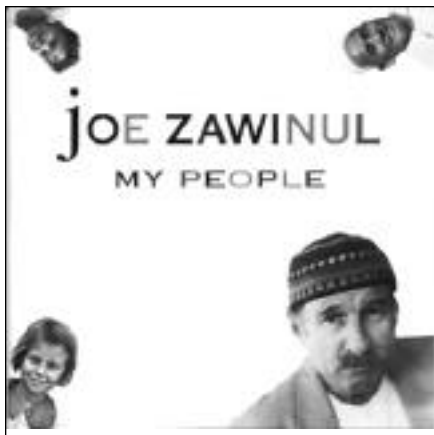

PRELUDES, AIRS & YODELS

by Penguin Cafe Orchestra

Producer: Simon Jeffes for Virgin Records, London, UK, 1996

Price: AUD\$19.95 (cass); AUD\$26.95, STG£10.00 (CD)

Available: **Aust**—Festival Records, ph (02) 9660 4022; **UK**—Virgin Records

If you're not yet a Penguin Cafe aficionado, then you sure will be after hearing this album. The Penguin Cafe's history goes back to 1976 with their first release, *Music from the Penguin Cafe*. All musicians are accomplished classical players and all want something a bit different from their music—as well as to strike "a blow against pomposity", in the words of Simon Jeffes, Penguin writer and founder. The Cafe Orchestra wheels past a musical smorgasbord of violin, cello, penny whistle, ukelele, harmonium, oboe and more. They stretch classical to the limit and arrive at a whole new place. My top album of the year (so far)!

FLAMENCO FALSETAS

by Dickson & Martinez

Producers: Peter Dickson & Juan Martinez, Melbourne, Aust, 1994-1996

Price: AUD\$19.95 (cass); AUD\$29.95 (CD)

Available: **Aust**—MRA Entertainment, ph +61 (0)7 3849 6020.

Juan Martinez was born in Madrid and Peter Dickson in Bangalore, southern India. Early on, each undertook training in their own musical styles. Later, meeting in Melbourne, Australia, they formed a duo and made their name outside Flinders Street railway station, playing and drumming up a flamenco storm. They have recorded for several TV networks and festivals and were approached to put their music on CD. This is the result. Excellent album.

WANDJINA: Dancing the Dreamtime by 93-D

Producer: Ray Vanderby for One World Music, Qld, Australia, 1996

Price: AUD\$19.95, STG£6.95 (cass); AUD\$29.95, STG£10.95 (CD)

Available: **Aust**—New World Productions, ph (07) 3367 0788; **UK**—New World Company, ph 0986 781682.

There are many albums of Aboriginal music about today, but the work of Ray Vanderby as 93-D really stands out. Having heard his several previous releases, this one is special. This album's combination of bagpipes, didgeridu, keyboards and percussion captures a sacred, almost other-worldly quality. Traditional sounds are mixed with a very quiet, earthy, hypnotic and rhythmic beat. Outstanding tracks are "Moon Dancer" and "Wankan Tankan". Highly recommended.

Endnotes

1. Barnet, Richard J. and Cavanagh, John, *Global Dreams: Imperial Corporations and the New World Order*, Simon & Schuster/Touchstone, New York, 1995, p. 14.
2. Chomsky, Noam, "Rollback: The Return of Predatory Capitalism," *Alternative Press Review*, Winter 1996, p. 45.
3. Grossman, Richard, "Corporations must not supplant 'we the people'", *Maine Telegram*, 4 February 1996.
4. Barnet and Cavanagh, op. cit., pp. 171-2.
5. Barnet, Richard J. and Mueller, Ronald E., *Global Reach: The Power of the Multinational Corporations*, Simon & Schuster/Touchstone, New York, 1974, pp. 175-6.
6. Zoll, Daniel, "Global Warning: The International Forum on Globalization may signal a new agenda for the progressive movement", San Francisco Bay *Guardian*, 22 May 1996. The example was from a presentation by Indian activist Vandana Shiva at the IFG conference.
7. Chomsky, Noam, "The Free Market Myth", *Open Eye*, no. 3, 1995, p. 12.
8. Barnet and Cavanagh, op. cit., pp. 250-6.
9. Jeremy Seabrook, *Victims of Development: Resistance and Alternatives*, Verso, London, 1993, p. 10.
10. Kaplan, Refet, "Conference on cities may end up in gridlock", *Washington Times*, 3 June 1996, p. A1.
11. Chomsky, Noam, "Rollback...", pp. 43-4.
12. (a) Pisik, Betsy, "Record numbers of people declaring bankruptcy", *Washington Times*, 9 June 1996, pp. A1, 14.
- (b) Crutsinger, Martin, "US consumer debt rises as uses of credit cards expand", Associated Press, as published in *Washington Times*, 13 April 1996, pp. B7, 9.
13. Bartlett, Donald L. and Steele, James B., *America: What Went Wrong?*, Andrews & McMeel, Kansas City, USA, 1992, p. 47.
14. Greider, William, *Who Will Tell the People?*, Simon & Schuster/Touchstone, New York, 1993, pp. 341-2.
15. Barnet and Cavanagh, op. cit., pp. 345-6.
16. "G7 Set Seal on Serious Summit", Reuter, 30 June 1996.
17. Barnet and Cavanagh, op. cit., pp. 407-8.
18. Kaplan, Robert D., "The Coming Anarchy", *Atlantic Monthly*, February 1994, p. 46.
19. op. cit., p. 58.
20. (a) Schiller, Herbert I., *Information Inequality: The Deepening Social Crisis in America*, Routledge, New York, 1996, p. 67.
- (b) Barnet and Cavanagh, op. cit., pp. 153-4.
21. Stauber, John C. and Rampton, Sheldon, *Toxic Sludge Is Good For You: Lies, Damn Lies and the Public Relations Industry*, Common Courage Press (Box 702, Monroe ME 04951), USA, 1995. This investigative book (236 pages) is strongly recommended. To order with Visa or MC (US\$16.95 plus \$3 postage in US), call 1-800 497 3207 or fax (207) 525 3068.
22. Goldin, Greg, "The Toughest Accounts: How Madison Avenue Sells Foreign Dictators", *Mother Jones*, January 1985, pp. 27-31.
23. "State Department and Intelligence Community Involvement in Domestic Activities Related to the Iran-Contra Affair", Staff Report, Committee on Foreign Affairs, US House of Representatives, 7 September 1988 (33 pages).
24. (a) Stauber and Rampton, pp. 169-74.
- (b) MacArthur, John R., *Second Front: Censorship and Propaganda in the Gulf War*, Hill and Wang, New York, 1992, pp. 37-77.
- (c) Rowse, Arthur E., "Flacking for the Emir", *Progressive*, May 1991, pp. 20-2.
25. Carlsson, Chris, "The Shape of Truth to Come: New Media and Knowledge", in *Resisting the Virtual Life: The Culture and Politics of Information* (James Brook and Ian A. Boal, eds.), City Lights, San Francisco, USA, 1995, p. 243.
26. Schiller, p. 8.
27. Carey, Alex, *Taking the Risk Out of Democracy: Propaganda in the US and Australia* (Andrew Lohrey, ed.), UNSW Press, Kensington, NSW, Australia, 1995.

About the Author:

Daniel Brandt is the founder and president of Public Information Research (PO Box 680635, San Antonio TX 78268, USA), a tax-exempt organisation that publishes *NameBase NewsLine*. In 1969 he was prosecuted for draft resistance, in 1976 he dropped out of a Ph.D. program at the Graduate Theological Union in Berkeley, and during the 1980s he lived in the Washington, DC, area and worked with *CounterSpy* magazine. He has also been an electronics hardware engineer, and currently writes custom database software on a consulting basis when he's not expanding *NameBase*.

Continued from page 22

- Organization of the United Nations, p. 85.
22. *Webster's New World Dictionary*, Simon & Schuster, NY, Second College ed., 1982.
23. Annand, J. C., "Hypothesis: Heated milk protein and thrombosis", *J. Atherosclerosis Res.* 1967:7, pp. 797-801.
24. Carper, J. "High vitamin C levels boost production of good cholesterol", *Seattle Post Intelligencer*, 10 August 1994.
25. Price, W. A., *Nutrition and Physical Degeneration*, Keats Pub., New Canaan, CT, USA, 1945.
26. Pariza, M. W., "Newly recognized anti-carcinogenic fatty acid identification and quantification in natural and processed cheeses", *J. Ag. Food Chem.* 1989:37, pp. 75-81.
27. Taylor, C. B. et al., "Spontaneously occurring angiotoxic derivatives of cholesterol", *Am. J. Clin. Nutr.* 1979:32, pp. 40-57.
28. Hattersley, J. G., "Acquired atherosclerosis: Theories of causation, novel therapies", *J. Orth. Med.* 1991:6, pp. 83-98.
29. Hattersley, J. G., "Vitamin B6: The overlooked key to preventing heart attacks", *J. Applied Nutrition* 1995:47, pp. 24-31.
30. Hattersley, J. G., "The importance of vitamin C and vitamin B6 in prevention and reversal of acquired atherosclerosis", *J. Orth. Med.* (in press).
31. "Microwave tragedy", *PPNF Nutr. J.* 1994:18(1&2), pp. 1-5.

About the Author:

Joseph G. Hattersley is an independent medical health researcher and writer. Only a dissertation short of a Ph.D. in economics, he became a stockbroker and research analyst, but found a new calling 20 years ago, at age 54, when a serious allergy turned his attention to finding ways to improve his own and others' health.

For the last 13 years Mr Hattersley has been writing on such subjects as non-drug/non-surgical avoidance of heart attacks and the role of vitamin B6, and his work has been published in alternative medical and health journals around the world. He was a contributor to the book, *Alternative Medicine: The Definitive Guide* (1993), for which he wrote the chapter on cardiac health.

Working with two Australian physicians, Mr Hattersley has been writing a book on heart attacks, due for 1997 publication by Lothian, Melbourne. His other new book, tentatively titled *Stopping Crib Death* (co-written with Dr Lendon Smith, et al.), is scheduled for late 1997/early 1998 release.

Continued from page 44

Tomatis Method

- enhanced and accelerated learning
- reversal of problems of language and speech acquisition
- increased information integration
- efficiency of communication, self-expression and self-perception
- improved vocal range and hearing
- reversal of behavioural problems such as attention, concentration, memory, aggression, hyperactivity and regressive tendencies.
- problems with lateral dominance and handedness
- reversal of learning disabilities and problems with reading, writing, spelling and calculation

The reversal of language, speech, behaviour and learning disabilities that were previously thought to be irreversible is a very real proposition using the innovative patterns of delivery, gating, bone- and ear-conductive methods of the Tomatis Method.

BioAcoustics

- support for improvement of sports injuries and trauma

- blood chemical evaluation
- predictive biological system analysis for insurance and medical models
- individualised medications that would reduce side-effects
- medical monitoring through voice spectral analysis via telephone
- drug and chemical screening for law enforcement agencies
- large area pest control without creating environmental side-effects
- as an insect or shark repellent
- as a non-toxic fertiliser
- food preservation through low-frequency presentation
- reversal of environmental pollution

The attempts to reverse sports injuries have led to the mapping of each muscle as it responds to low-frequency sound. Using brain-wave entrainment, we have been able to strengthen weak muscles, weaken overstimulated or blocked muscles, alleviate a considerable amount of pain and reduce recovery time.

BioAcoustic blood chemical evaluation is an actual program of information that will show the relationship of chemical elements within the body. Using a non-intrusive vocal print, the presence and usage of chemical elements can be determined. The

technique provides instant feedback, and is very inexpensive to administer and execute. This technique has the potential to add to the present medical database regarding the interrelationships of chemical elements. It could be used by nutritional outlets, medical and hospital laboratories and individuals who take supplements. The elimination of drug-related side-effects is also a potential outcome of this technique.

Sound therapy has shown considerable promise to allow scientists to glimpse the interconnected systems of the body; not just as closed systems that work together but the actual play between muscles and muscles, muscles and biochemistry, muscles and emotions, etc.

Using vocal prints of all individuals involved, problem areas and compatibilities can be identified. This technique could work well in negotiation settings, work disputes, marriage and family counselling, etc.

As for other applications, in one test using low-frequency sound, mosquito pests have been persuaded to leave an area. Studies have been conceived for repelling or attracting any pest species using low-frequency sounds.

Continued on page 92

Continued from page 91

In food preservation and storage technology applications, only one pilot project has been completed but the results show that low frequencies can retard spoilage.

BioAcoustic sound therapy has potential in reversing the effects of pollution and poisons, whether they be in the body or in the Earth.

Recommended Reading

- Becker, Robert O., *Cross Currents*, Jeremy P. Tarcher, Inc., Los Angeles, CA, USA, 1990.
- Becker, R. O. and Sleden, G., *The Body Electric*, Guill, New York, NY, USA, 1985.
- Bonny, H. and Savary, L., *Music and Your Mind*, Station Hill Press, Barrytown, NY, USA, 1990.
- Brown, Wendall, Johns Hopkins University, papers.
- Cowan, James P., *Handbook of Environmental Acoustics*, Van Nostrand Reinhold, New York, NY, USA, 1994.
- Edwards, Sharry, *Published Papers - 1982-1993*, Signature Sound Press, Athens, OH, USA, 1995, 12th Edition.
- Edwards, Sharry, *Published Papers - 1993-1995*, Sound Health Publications, Athens, OH, USA, 1996.
- Edwards, Sharry, "Five Cases Suggesting that Biological Screening for Chemical Elements can be Facilitated through Voice Spectral

Analysis", *MegaBrain Report*.

- Edwards, Sharry, "Low Frequency Sound: Its Efficacy as a Biofeedback Modality to Verify Muscle Strength and Weakness" (pilot research report), Sound Health Press, Athens, OH, USA, 1996.
- James, Jamie, *The Music of The Spheres*, Copernicus of Springer-Verlag, New York, NY, USA, 1993.
- Gerber, Richard, *Vibrational Medicine*, Bear & Company, Santa Fe, NM, USA, 1988.
- Godwin, Joscelyn (ed.), *Cosmic Music*, Inner Traditions, Rochester, VT, USA, 1989.
- Halpern, Steven, *Sound Health*, Harper & Row, San Francisco, CA, USA, 1985.
- Hunt, Valerie, *Infinite Mind*, Malibu Publishing, Malibu, CA, USA, 1996.
- O'Connor, M. E., Bentall, R. H. C., Monahan, J. C. (eds.), *Emerging Electromagnetic Medicine*, Springer-Verlag, New York, NY, USA, 1990.
- Pond, Dale, *Vibratory Physics*, Delta Spectrum Research, Tulsa, OK, USA, 1995.
- Srinivasan, T. M. (ed.), *Energy Medicine Around The World*, Gabriel Press, Phoenix, AZ, USA, 1988.
- Talbot, Michael, *The Holographic Universe*, HarperCollins, New York, NY, USA, 1991.
- Tomatis, Alfred A., *The Conscious Ear*, Station Hill Press, Barrytown, NY, USA, 1991.
- Tomatis, Alfred A., *The Ear and Language*, Moulin Publishing, Norval, Ontario, Canada, 1996.

For further information on sound therapy, contact:

BioAcoustics Headquarters:

- Signature Sound Works, Inc. Sound Health Alternatives International 1007 East State Street Athens, Ohio 45701, USA Telephone: (614) 592 5115 Fax: (614) 592 6116 Email: 1032113.1127@compuserve.com Web: <http://www.frognet.net/biosound>

Tomatis Centres:

- Sound Listening and Learning Centre, Phoenix, AZ, USA, telephone (612) 381 0086; contact, Billie M. Thompson, Ph.D.
- The Tomatis Centre (UK), Lewes, E. Sussex; telephone: +44 01273 478666.
- The Australian Tomatis Centre, Gordon, NSW; telephone (02) 9418 4130.

Sound Therapy Centres:

- Sound Education (Australia), Melba, ACT; telephone (06) 259 1364; contact, Kay Distel.

Continued from page 59

exactly due east of the Exmouth VLF Tx site and, intriguingly, are also located upon a Magnetic North Pole great circle route from Exmouth's sister transmitter complex located at Cutler, Maine, on the northeastern seaboard of the USA near the Canadian border.

Thus, if the several sightings concerning fireballs emanating from Exmouth (reported during the period 1973 to 1994) to the east towards the Great Sandy Desert are taken into account, it would appear that this area of Australia has been utilised for the testing and eventual deployment of a diabolical EM weapons system of prodigious power.

Slugs of EM energy could have been fired from Exmouth and steered or explosively initiated from Cutler, and/or other US global transmitter sites onto the target test range within the Great Sandy Desert to initiate major earthquakes in a region previously and totally devoid of same.

On a globe one can see that the great circle geographic polar route north from Exmouth passes through the following locations: Hong Kong; Thule (US air base in Greenland); Cutler, Maine (known VLF Tx); Arecibo, Puerto Rico (known VLF Tx); Tucumán, Argentina (known VLF Tx); Palmer and Amundsen-Scott US Antarctic bases; back to Exmouth Tx in NW Australia. Such a series of Tx sites would allow good coverage of the entire planet.

Interestingly, the Puerto Rico site is a near exact antipodean site for Exmouth, and both sites are areas where UFO sightings are common—especially Arecibo, where I suspect the sightings are mainly atmospheric

Tesla light-energy-emission 'UFOs' from the testing and operation of both Tx EM weapon sites.

There are many fascinating coincidences in this research. Take for instance the case of Harold E. Holt, Prime Minister of Australia from 26 January 1966 to 19 December 1967. He disappeared whilst swimming one Sunday—apparently after reporting to family and close colleagues over the preceding days that he had discovered something about the USA, its activities here and its future intentions, that deeply offended and worried him. Intending to raise these issues in Cabinet and then Parliament on the following Monday, he was never seen again.

Rumours of CIA assassination, shark attack or removal by Chinese submarine have continually surfaced over the years. Recent stories even suggest that Holt is alive and well in China...

The Exmouth Peninsula communications base is now called the "Harold E. Holt Naval Communication Station". One would think that the Australian Federal Police or ASIO/ASIS could have solved the disappearance and/or possible murder of an Australian Prime Minister in some 30 years. One does not have to look too far for a connection and possible line of enquiry.

Then there is the case of the two young cattle-station hands who died under very mysterious circumstances a few years ago in the Great Sandy Desert—on the very seismic grid-lines put in by Aquitaine Oil, and within the very area of the Great Sandy Desert "earthquake test range"...

It would appear to be high time for Australians to do something about this state

of affairs—since we actually host a weapons system that has led clandestinely to the deaths not only of Australians but quite probably of tens of thousands of fellow humans in many countries across the globe.

But all of that—the science of earthquake-inducing EM weapons systems and their recent deployment and use on planet Earth by Russian, Japanese and American forces—must wait until the next article in this series.

Any person seeing, or having seen, exotic "meteor fireballs", or knowing anything about same or exotic EM weapons systems, is invited to contribute to this research project by telephoning the author on +61 (0)9 525 5999 (after 10.00 am WA time = gmt + 8 hours), faxing on +61 (0)9 525 5944, or e-mailing on orbitx@ois.com.au.

About the Author:

Harry Mason, BSc, MSc, MAIMM, MIMM, FGS., is a UK-born geologist/geophysicist, resident in Perth, Western Australia. His 30-year career in mineral exploration has had him stationed all over the world, including Alaska, India, Norway, Mexico, Morocco, Sudan and UK. He has extensive field experience in geo-recce, geological mapping, geophysics/geochemistry, prospecting, remote-sensing/computer imaging technologies, and seismic and electromagnetic studies. He specialises in the geology and resource exploration of WA's Eastern Goldfields. Lately he has been devoting his time and expertise to researching mysterious Australian outback phenomena of natural and man-made origins.